

CERTIFIED CORRECT COPY
OF APPROVED DRAWINGS
AT THIS DATE.....

17.11.2020

Design & Drawing Office
Ordnance Factory,
Truichirapalli-620016

UN CONTROLLED COPY

MATERIAL FOR INDIA:-

DS-978-PT4-1983-RR-026-N-31-OR IS:5517-1993

DESIG. 31 Ni10 Cr3 Mo6 WITH RESTRICTION
OF 'S' & 'P' CONTENT UPTO 0.025% MAX. FOR EACH LRS. 63mm
STRESSED COMPONENT.

NOTE

ACCEPTANCE STANDARDS FOR MACRO ETCH TEST & MICROSCOPIC
DETERMINATION OF NON METALLIC INCLUSIONS FOR STEEL
1. MACRO ETCH TEST AS PER ASTM E- 381 WITH
ACCEPTANCE STANDARD AS C2, R2, S2

2. NMR TEST AS PER IS : 4163 - 82

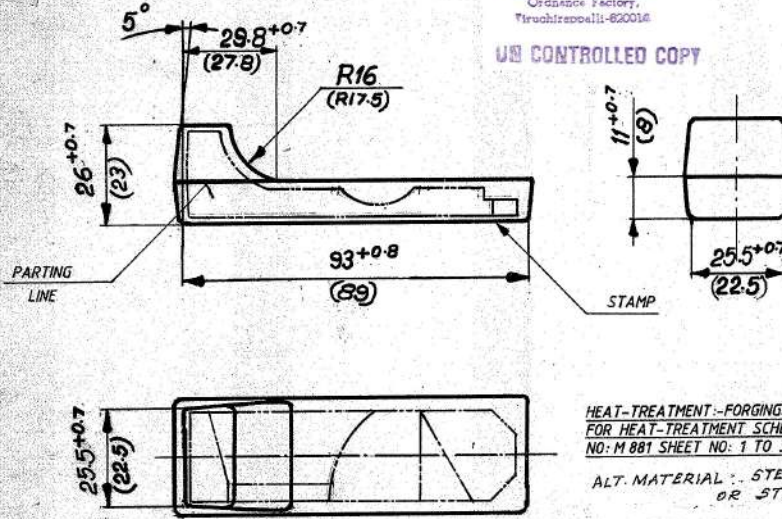

HEAT-TREATMENT:-FORGINGS ARE NORMALIZED AND TEMPERED.
FOR HEAT-TREATMENT SCHEDULE REFER DRAWING
NO: M 881 SHEET NO: 1 TO 3 AND SHEET NO: 4, SL. NO:7.

ALT. MATERIAL :- STEEL 30XH2 MΦA DST 3-98-80
OR STEEL 30XH2 MΦA GOST 4543-71

MATERIAL :- STEEL 30X PA DST 3-98-80

NOTES:-

- DIMENSIONS ARE IN mm.
- FIRST ANGLE PROJECTION.
- SCALE :- 1:1
- FORGING OF GROUP III AS PER GOST 8479-70, HB 255 MAX.
- DRAFT ANGLE 7° UNLESS OTHERWISE SPECIFIED
- UN-SPECIFIED RADII 15R.
- FLASH REMAINDER UP TO 0.5 mm.
- WARPING UP TO 0.4 mm.
- CONVENTIONAL CONTOUR AND DIMENSIONS GIVEN IN BRACKETS PERTAIN TO THE FINISHED PART.
- STAMP PART NO, MELT NO. AND QCD STAMP ON THE FORGINGS.
- 100% OF A BATCH SHOULD BE CHECKED FOR HARDNESS AS PER GOST 8479-70.
- WEIGHT OF THE FORGING 0.28 Kgs.

| CHEMICAL COMPOSITION & MECH. PROPERTIES OF MATL. :- 30XH2MΦA | | | |
|--|-------------|-------------------|-------------------------|
| C | 0.27 - 0.34 | P | 0.025 MAX. |
| SI | 0.17 - 0.37 | CU | 0.20 MAX. |
| Mn | 0.30 - 0.60 | HARDNESS | HB 269 |
| Cr | 0.60 - 0.90 | ELONGATION | 10 % |
| Ni | 2.0 - 2.4 | REDUCTION IN AREA | 40 % |
| Mo | 0.20 - 0.30 | IMPACT STRENGTH | 9 Kgf M/cm ² |
| V | 0.10 - 0.18 | TENSILE STRENGTH | 90-Kgf/mm ² |
| S | 0.025 MAX. | YIELD POINT | 80 Kgf/mm ² |

VETTED FOR MATERIAL ONLY

Principal Scientific Officer,
Quality Assurance Officer,
For Service Quality Assurance Officer,
Service Quality Assurance Estt. (Arms)
Truichirapalli-620 016.

COMPONENT DRG. NO. 6P11-2-32

LOCK BARREL

DRAWING PROVISIONAL

DS.CAT NO.
1005007286

ORDNANCE FACTORY,
TRUICHIRAPALLI-16.

DRG. NO:

E3

REDRAWN

CHECKED

11.87
APPROVED

I/C. D&DO

DIV. OFFICER

62 C 2032 200