

M-1015

NOTES:

1. FINISH $\sqrt{32}$ ALL OVER.
2. BREAK ALL EDGES 0.076 +0.305 UNLESS OTHERWISE SPECIFIED.
3. MATERIAL: CASTING, IRON, MALLEABLE, PEARLITIC, ASTM A220, GRADE 45006 OR CONTINUOUSLY CAST GRAY IRON BAR ASTM A48, CLASS 40 (DURA-BAR G2).
4. FINAL PROTECTIVE FINISH: MALLEABLE OR DUCTILE IRON: FINISH 5.3.1.2 OR 5.3.2.2 OF MIL-STD-171.
5. ASME Y14.5M-1994 APPLIES.
6. ALTERNATIVE MATERIAL: IRON, DUCTILE CASTINGS, ASTM A536, GRADE 80-55-06 OR ASTM A536, GRADE 65-45-12.
7. MIL-STD-2175, CLASS 2, GRADE C, SHALL BE APPLICABLE FOR INSPECTION OF MALLEABLE OR DUCTILE IRON CASTINGS.

NOTE 7 APPLIES RT

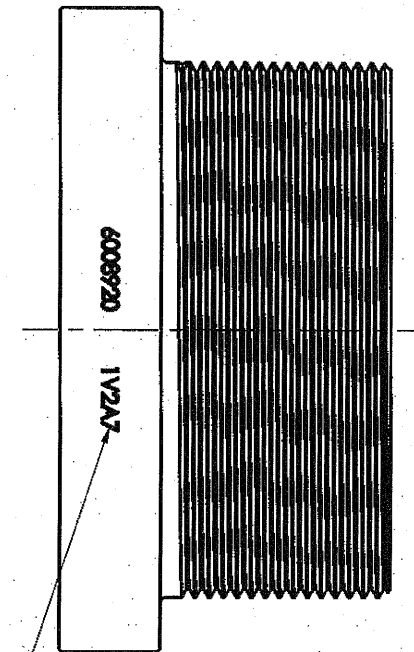

INSCRIBE OR CAST PART NUMBER 6008920 AND PRIME CONTRACTOR'S CAGE CODE IDENTIFICATION, 1.575 ± 0.381 HIGH X 0.127 +0.381 DEEP.

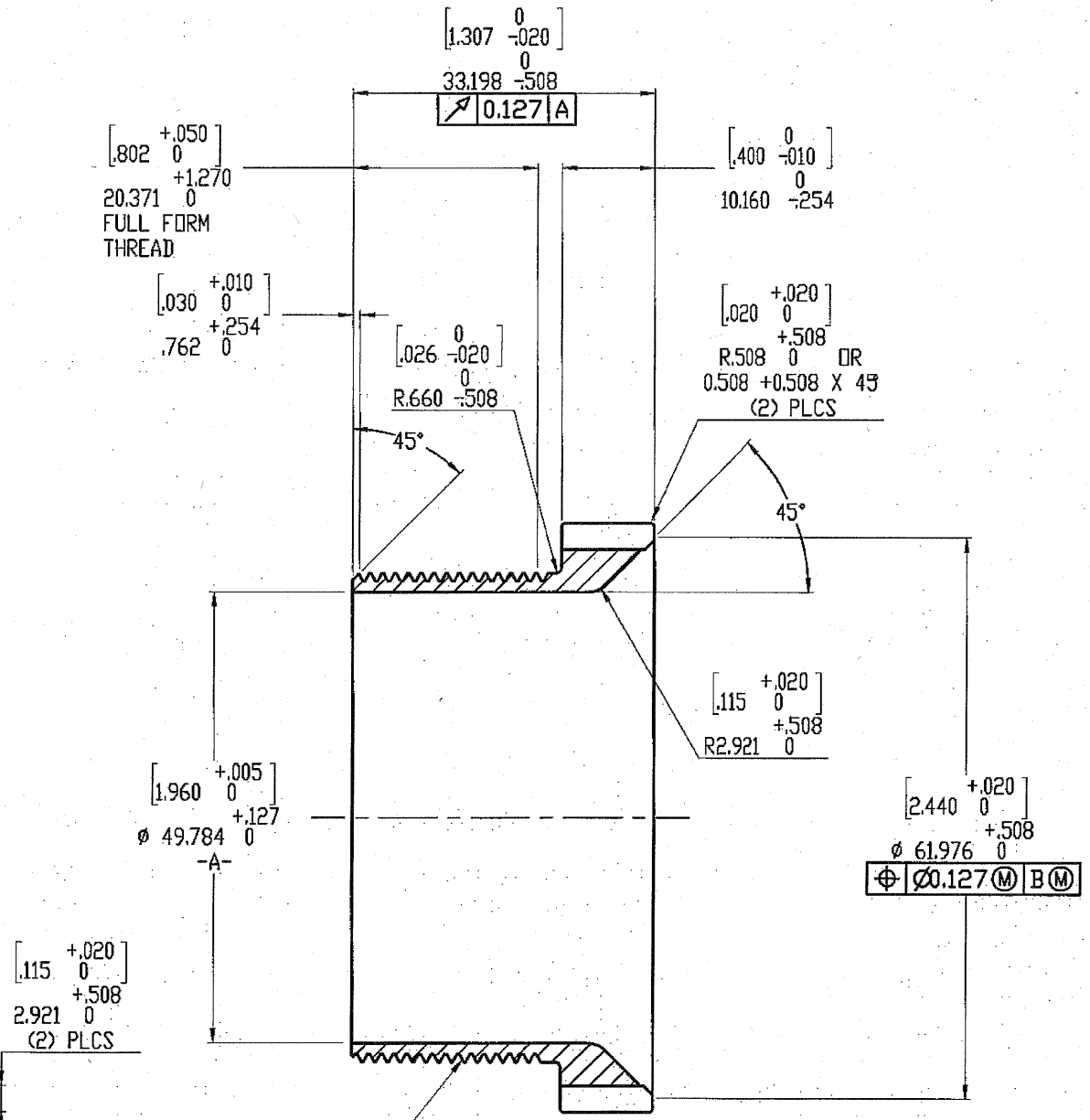
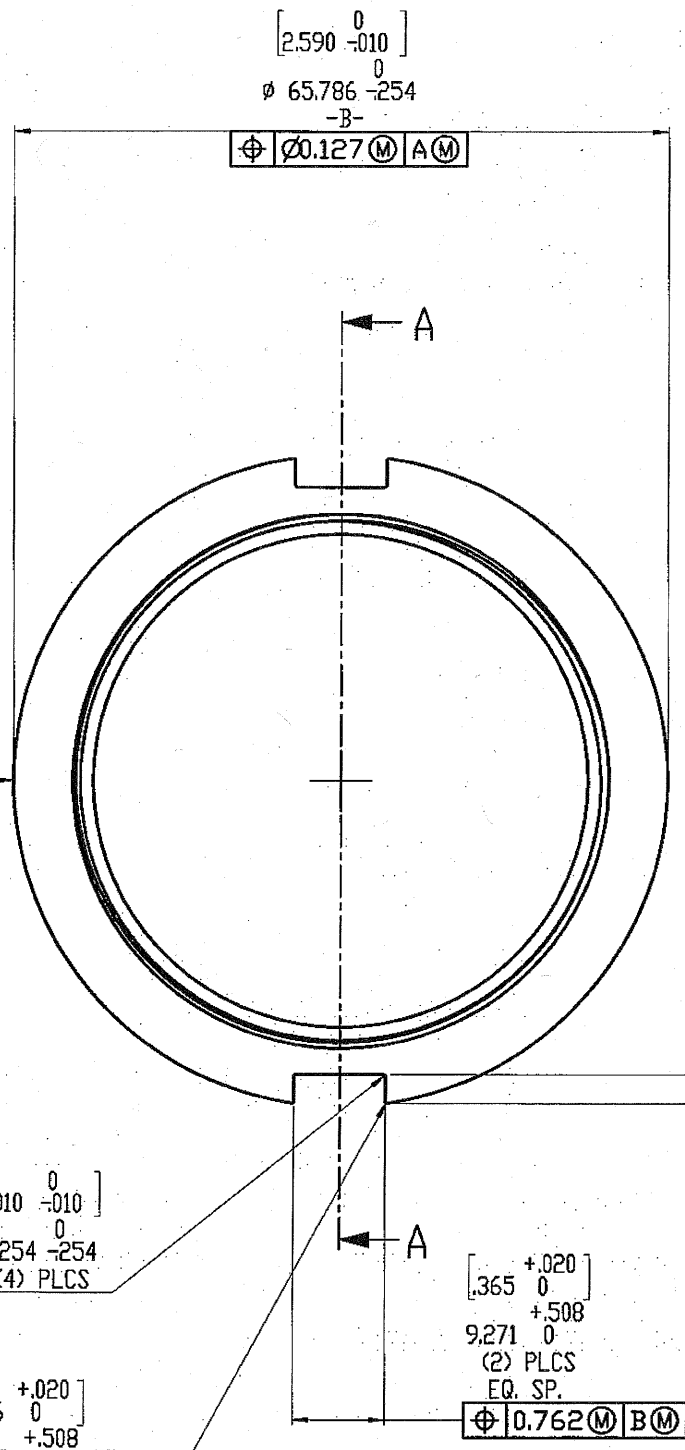

REVISIONS				
ZONE	REV.	DESCRIPTION	DATE	APPROVED
	A	CREATE DRAWING	5/30/2015	G. HERSHBERGER
	B	MATERIAL ADDED ASTM A48 CLASS 40(DURA-BAR G2)	6/3/2015	G. HERSHBERGER

SECTION A-A

UN CONTROLLED COPY
 CERTIFIED CORRECT COPY OF APPROVED
 DRAWINGS AT THIS DATE 29-09-2021

Provisionally Approved
 4 AUG 2021
 Design & Drawing Office
 ORDNANCE FACTORY, TIRUCHIRAPPALI - 620 016.

ITAR CONTROLLED THIS DOCUMENT IS CONTROLLED UNDER THE ITAR. IT MAY NOT BE PROVIDED TO A NON-US RESIDENT WITHOUT THE WRITTEN APPROVAL OF THE US GOVT. VIOLATIONS WILL RESULT IN CIVIL OR CRIMINAL PENALTIES. PROPRIETARY AND CONFIDENTIAL. THE INFORMATION CONTAINED IN THIS DRAWING IS THE SOLE PROPERTY OF OHIO ORDNANCE WORKS, INC. ANY REPRODUCTION IN PART OR AS A WHOLE WITHOUT THE WRITTEN PERMISSION OF OHIO ORDNANCE WORKS, INC. IS PROHIBITED.	UNLESS OTHERWISE SPECIFIED DIMENSIONS ARE IN INCHES (IN PARENTHESES) ALL THREAD DIM ARE IN INCHES TOLERANCES: FRACTIONAL ANGULAR EACH 45° BEND TWO PLACE DECIMAL 4025 THREE PLACE DECIMAL 40127	NAME: PND DATE: 05/10/15	OHIO ORDNANCE WORKS, INC.
	INTERPRET GEOMETRIC TOLERANCING PER: MATERIAL: FINISH: DO NOT SCALE DRAWING	CHECKED: ENG APPR: NFG APPR: D.A. COMMENTS:	BEARING, BREECH, 00W50BMG
	SIZE: C	PART NUMBER: 6008920	REV: B
	SCALE: 2:1	WEIGHT:	SHEET 1 OF 1