

ENLARGED SECTION "A.A."

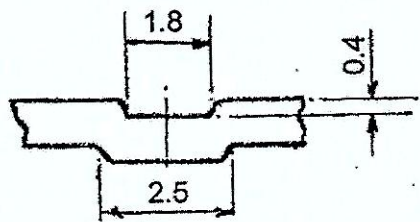

ENLARGED SECTION "B.B."

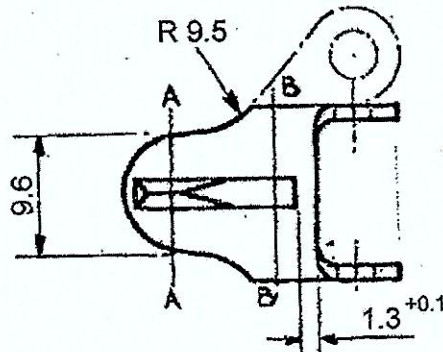

MMD  
 Certified as correct  
 of drg. on.....  
 16/09/18  
 E. SHARMA  
 Jr. Works Manager  
 STANDARD

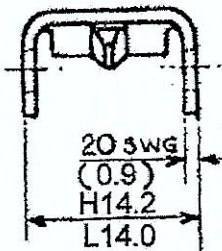
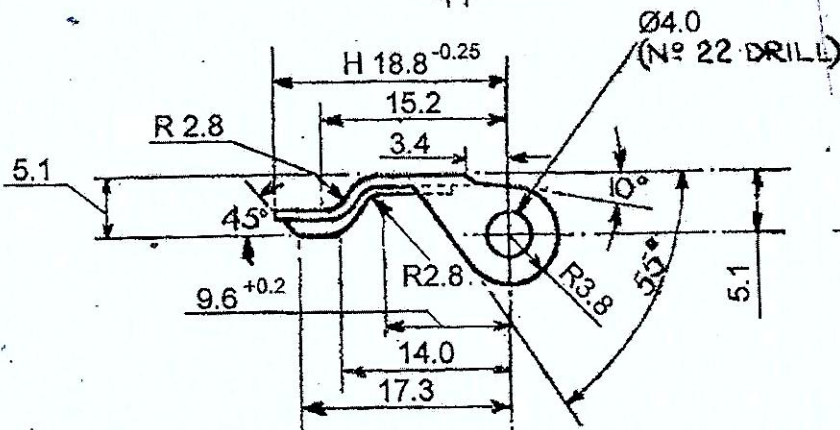

PROTECTIVE FINISH :- TO BE PASSIVATED ZINC PLATED TO IS : 1573

AUTH.	IHQ-MOD(N)/DAPI LETTER NO. API/9808, Dt. 26 July 19, ARD NO. 2572 dated 26 Jul 19				
	Zone B-3:- FOR:- H19.3 <sup>-0.25</sup> READ: H 18.8 <sup>-0.25</sup>				
	03-09-13	APPROVED		DGNAI	
R.No	DATE	ZONE	BRIEF RECORD	AUTHORITY	INITIALS
SCALE:- NTS		TOL.	DIMENSIONS ARE IN mm		ASSY DRG No:- NAD 7606
DGN	DRN	TCD	COMP	CHD	ASSY DRG LIST.
PASSED	APPD.	GEN SPEC :- NA SPEC A-31B		DTE GEN OF NAVAL	
CTO(D)	DGNAI	STORE SPEC :-		ARMAMENT INSPECTION	
MATL:-STEEL		STORE REF No.		IHQ,MOD (NAVY) N. DELHI	
MATL SPEC:- STA 5 V2B OR		GAUGE SCH No.			
IS : 1570(Part 2/Sec-1) : 1979, 10C4 OR		D.S. CAT No.			
BS : 1449 (Part 3A) : 1964 Gd HS12				DRG No.	
PROTECTIVE FINISH:- SEE DRG.				NAD 7606/2	

# STRIKER

A-4

USED ON:- STRIKER MECHANISM, N8 MK1

BASED ON:- NOD 8026/2 Dt. 23.11.55

TRIM ON THIS LINE WHEN SUPPLIED TO TRADE