

DRAWING NUMBER  
304-34

(V/A)

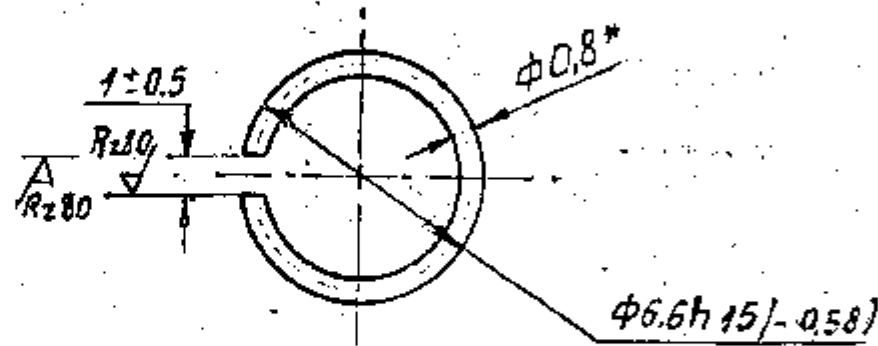

1. Зависенцы не допускаются.
2. Покрытие хим. окс. прм.
3. \*Размеры для справок.
4. Неплоскостность не более 0.8 мм (развод концов); местное искривление не допускается

1. BURRS ARE NOT PERMITTED.
2. COATING: CHEMICAL OXIDIZING OIL FINISHING.
3. \*DIMENSIONS FOR REFERENCE.
4. NON FLATNESS SHOULD NOT EXCEED 0.8mm SPREAD ENDS LOCAL DISTORTION IS NOT ALLOWED.

5. EXPLANATORY NOTE :

MATERIAL QUOTED :-

WIRE - II 0,8 GOST 9389-75

II - SECOND CATEGORY

0,8 - NOMINAL DIAMETER OF THE WIRE

CHEMICAL COMPOSITION :-

GRADE OF STEEL	CONTENT OF ELEMENTS %							
	C	Mn	Si	S	P	Cr	Ni	Co
KT - 2	0,86 - 0,91	0,20 - 0,40	0,17 - 0,37	0,020	0,020	0,05	0,05	0,10
SK - 7	0,68 - 0,76	0,50 - 0,80	0,17 - 0,37	0,030	0,020	0,05	0,05	0,04

MECHANICAL PROPERTIES :-

TENSILE STRENGTH  $kgf/mm^2$  215 - 260

NO: OF BENDS = 12 (MIN)

NO: OF TWISTS = 17 (MIN)

(A) EQUIVALENT MATERIAL  
Gr. SM/SH IS: 4454-2001

K V D No, 78085.

PLOT SAMPLE SHOULD BE APPROVED BY A H S P BEFORE BULK PRODUCTION

EST. WT. 0,001 Kg TO BE STAMPED OR MARKED WHERE INDICATED THIS # ( LETTERS)

ALL SHARP EDGES AND CORNERS TO BE REMOVED UNLESS OTHERWISE STATED MACHINED CORNERS TO HAVE R OUT SIDE INSIDE EQUIVALENT CHAMFERS ARE PERMISSIBLE

DRN	G. N. N. N.	MATERIAL :- WIRE II - 0,8	USED ON
CHD		GOST 9389-75	CB 3304-02-4
TCD	Avizata	CONTROLLERATE OF QUALITY ASSURANCE (HEAVY VEHICLES)	
APPD		AVADI	
DATE	05-05-88	TITLE	
SCALE :-	5:1	RETAINING RING	
DIMENSIONS IN mm		D S CAT NUMBER	
TOLERANCE ON DIMNS UNLESS OTHERWISE STATED IS: 2102-69		DRAWING NUMBER	
ALL THREADS TO CONFORM TO		304-34	
ISSUE DATE	NATURE OF AMENDMENTS		

A 16-8-10 4<sup>th</sup> Alt. Comm. Meeting Minutes  
Point No. 13 Dt: 26-10-09

A3  
116

SIZE A3



DRAWING NUMBER  
315-651-28

10  
(M)

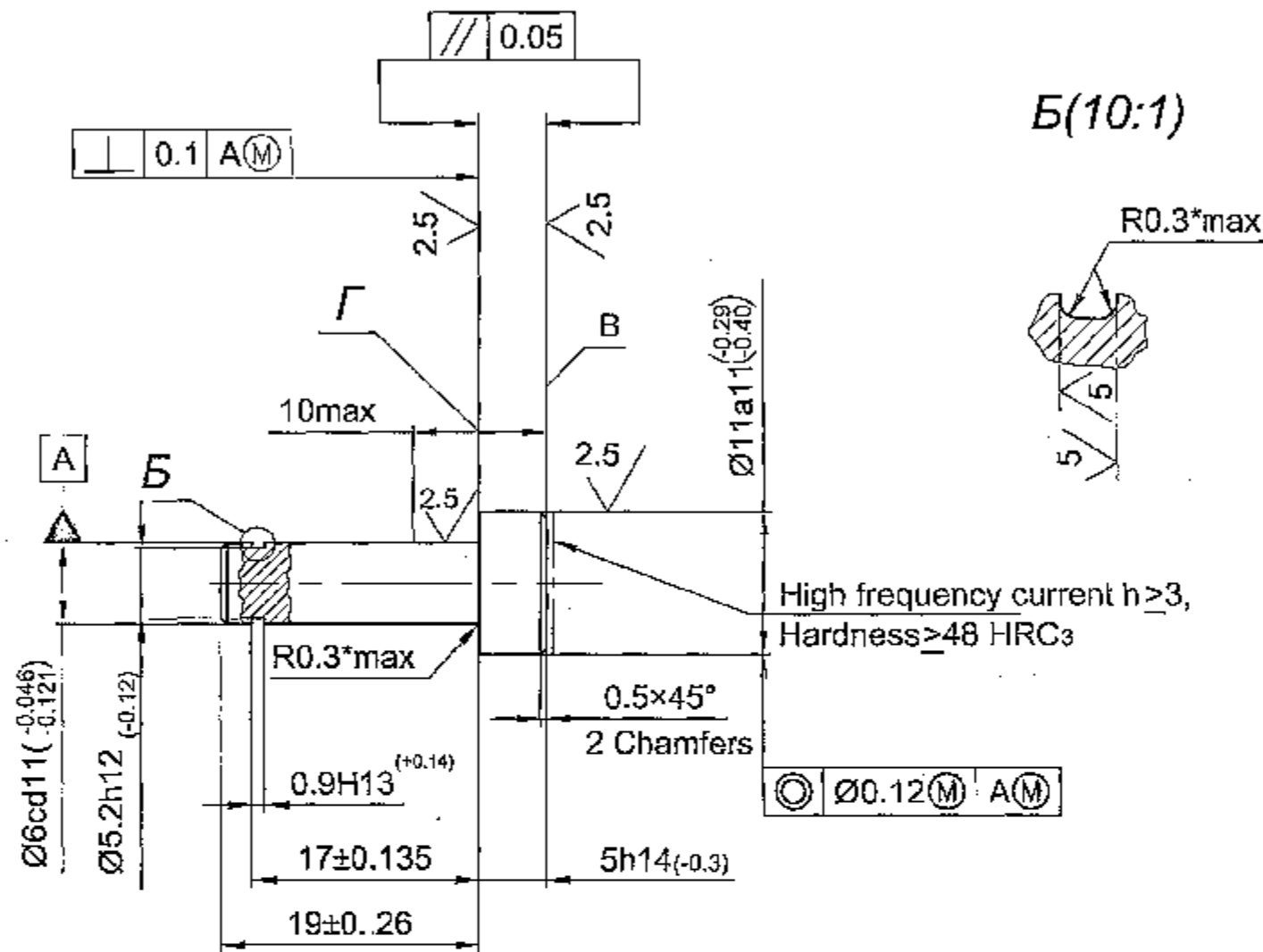

1. Inspection group is III as per TT-11.
2. \* Dimensions are ensured by tool.
3. Coating is carried out chemically oxidised, oiled as per instruction ИЛ-681-78.
4. Centred drill hole is not allowed on face B.
5. Hardening of surface A along length  $\Gamma$  is allowed.

High frequency current  $h \geq 3$ ,  
Hardness  $\geq 48$  HRC<sub>3</sub>

Ø0.12 M A(M)

DRAWING INDIANISED BASED ON RUSSIAN ORIGINAL ISSUE - 4

PILOT SAMPLE SHOULD BE APPROVED BY A H S P  
BEFORE BULK PRODUCTION.

EST. WT. 0.0055 TO BE STAMPED OR MARKED WHERE  
INDICATED THUS # ( LETTERS )

ALL SHARP EDGES AND CORNERS TO BE REMOVED UNLESS  
OTHERWISE STATED MACHINED CORNERS TO HAVE R OUT-  
SIDE R INSIDE EQUIVALENT CHAMFERS ARE PERMISSIBLE.

DRN	MATERIAL:- STEEL 45X GOST 4543-71	USED ON:- Cb 315-660-34 Cb 315-660-35
CHD	CONTROLLERATE OF QUALITY ASSURANCE (HEAVY VEHICLES) AVADI	
APPD	TITLE:- <b>CORRECTOR ROD</b>	
DATE	D S CAT NUMBER	DRAWING NUMBER 315-651-28
SCALE:- 2:1		
DIMENSIONS IN mm		
TOLERANCE ON DIMNS UNLESS OTHERWISE STATED IS : 2102 - 69		
ALL THREADS TO CONFORM TO		

F-5  
76  
283  
SIZE A3

ISSUE DATE NATURE OF AMENDMENTS



DRAWING INDIANISED BASED ON RUSSIAN ORIGINAL ISSUE - 4

DRAWING NUMBER  
**315-653-12**

10  
✓ (✓)

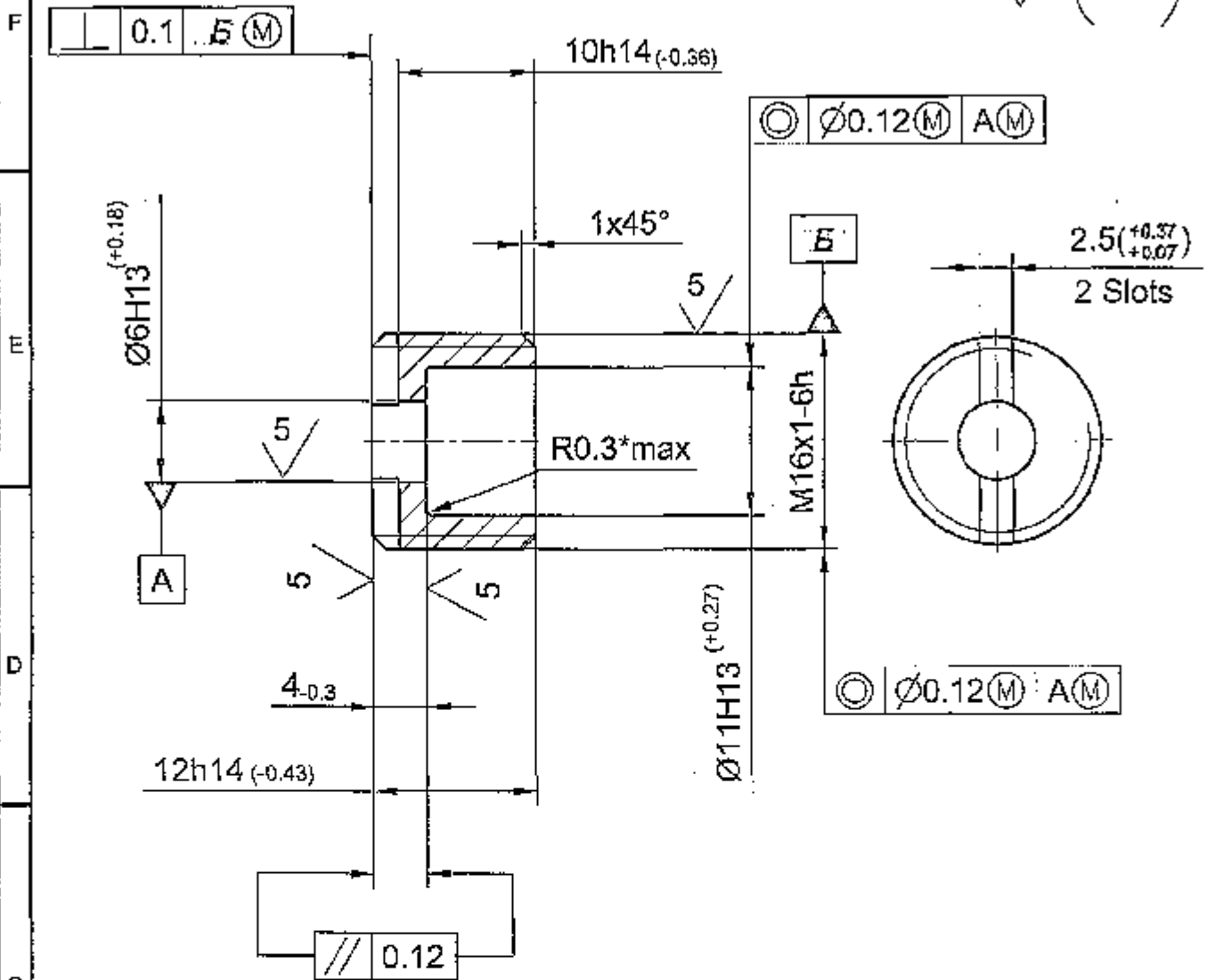

1. \* Dimension is ensured by tool.
2. Coating: Chemically oxidised oiled as per instruction *ИП-681-87*.

PILOT SAMPLE SHOULD BE APPROVED BY A H S P BEFORE BULK PRODUCTION.

F-5  
79  
283

EST. WT. (Kg)  
**0.01**

TO BE STAMPED OR MARKED WHERE  
INDICATED THUS # (        LETTERS )

ALL SHARP EDGES AND CORNERS TO BE REMOVED UNLESS  
OTHERWISE STATED MACHINED CORNERS TO HAVE R OUT-  
SIDE R INSIDE EQUIVALENT CHAMFERS ARE PERMISSIBLE.

MATERIAL :-  
STEEL 45  
GOST 1050-88

USED ON :-  
CS 315 -660 - 34  
CS 315 -660 - 35

4A 18-8-08 D. O. CORRECTION  
ISSUE DATE        NATURE OF AMENDMENTS

DRN  
*A. S. S.*  
SCALE :- 2 : 1  
DIMENSIONS IN mm

CONTROLLERATE OF QUALITY ASSURANCE (HEAVY VEHICLES)  
AVADI

CHD  
*P. B. S.*  
APPD  
TOLERANCE ON DIMENSIONS  
UNLESS OTHERWISE STATED  
IS : 2102 - 69

TITLE :-  
4A **CORRECTOR HOUSING**

DATE  
12/3/07  
ALL THREADS TO  
CONFORM TO

D S CAT NUMBER

DRAWING NUMBER  
**315-653-12**

SIZE A4







DRAWING INDIANISED BASED ON RUSSIAN ORIGINAL ISSUE - 3

F-5  
86  
283

DRAWING NUMBER  
**315 -797**

10  
✓ (✓)

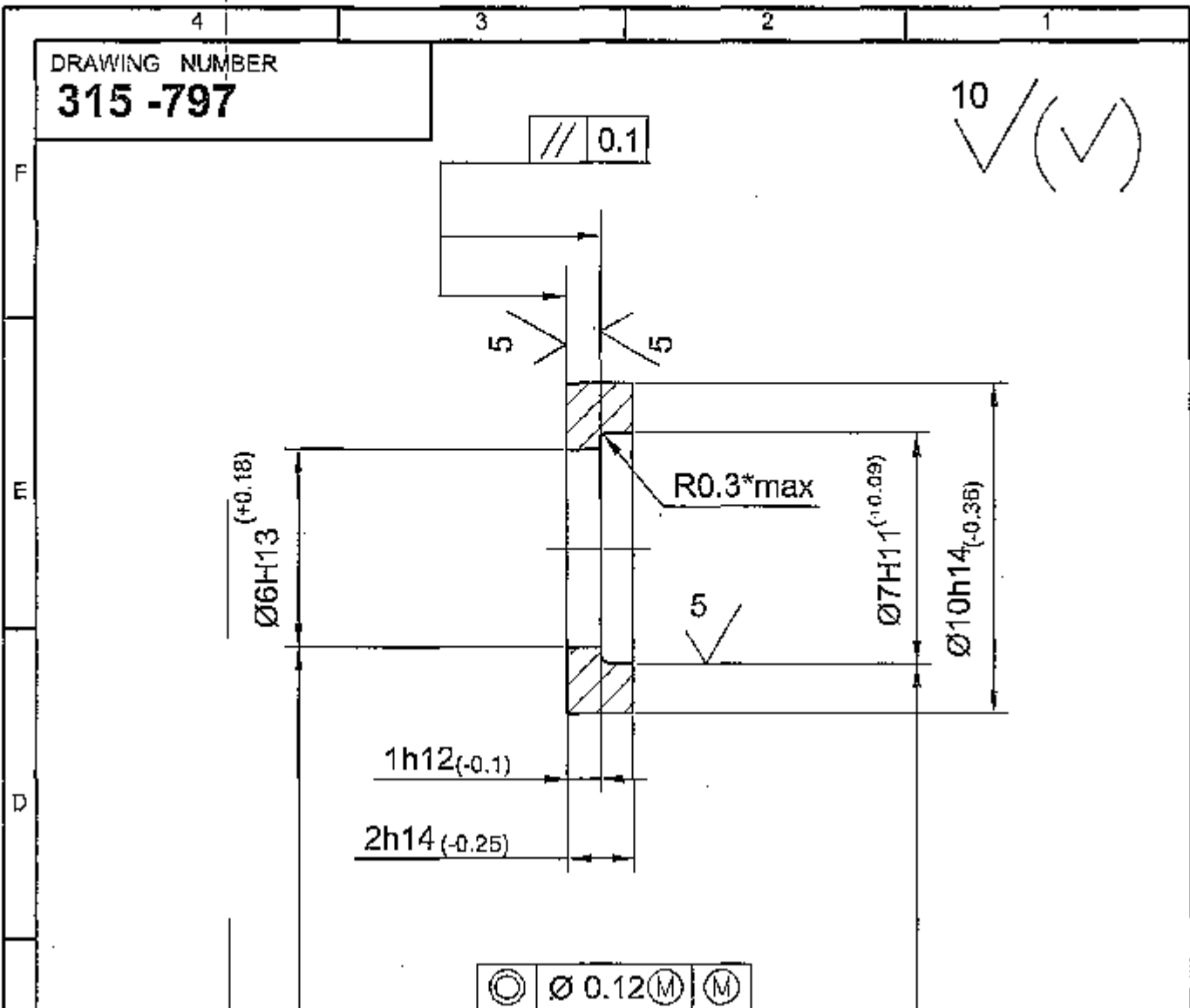

1. Inspection group is IV as per T T-11.
2. 28...35 HRC $\phi$ .
3. Coating: Chemically oxidised, oiled as per instruction ИЛ-681-87.
4. \* Dimension is ensured by tool.

PILOT SAMPLE SHOULD BE APPROVED BY A H S P BEFORE BULK PRODUCTION.

		EST. WT. (Kg) <b>0.0008</b>	TO BE STAMPED OR MARKED WHERE INDICATED THUS # (      LETTERS )
		ALL SHARP EDGES AND CORNERS TO BE REMOVED UNLESS OTHERWISE STATED MACHINED CORNERS TO HAVE R OUT-SIDE R INSIDE EQUIVALENT CHAMFERS ARE PERMISSIBLE.	
		MATERIAL :- STEEL 45X GOST 4543-71	USED ON :- C5 315 - 660 - 34 C5 315 - 660 - 35
ISSUE DATE	NATURE OF AMENDMENTS	CONTROLLERATE OF QUALITY ASSURANCE (HEAVY VEHICLES) AVADI	
DRN <i>Atul</i>	SCALE :- 5 : 1	TITLE :- <b>WASHER</b>	
CHD <i>R. B. ...</i>	DIMENSIONS IN mm		
APPD <i>[Signature]</i>	TOLERANCE ON DIMENSIONS UNLESS OTHERWISE STATED IS : 2102 - 69	D S CAT NUMBER	
DATE 21/3/67	ALL THREADS TO CONFORM TO	DRAWING NUMBER <b>315 -797</b>	
SIZE A4			

DRAWING NUMBER  
**Cb.315-660-35**

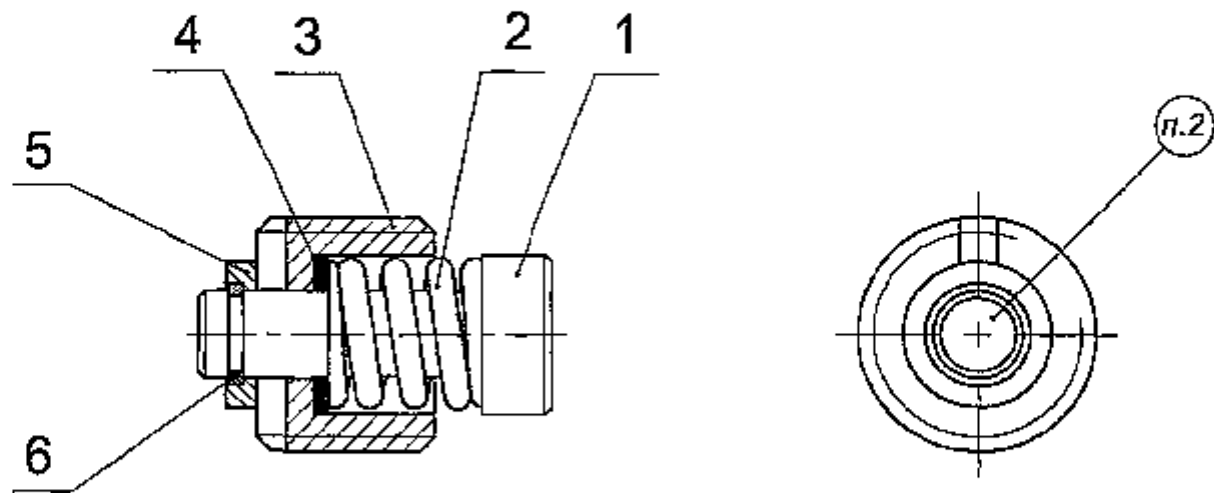

1. Tighten the corrector spring item 2 with the help of adjusting washer set item 4 in such a way, that under the load of 122.5N (12.5 Kgf), corrector rod item 1 with relative to corrector body item 3 should be equal to  $1 \pm 0.05$  mm.
2. Mark the letter K by electric spark method.

DRAWING INDIANISED BASED ON RUSSIAN ORIGINAL ISSUE - 4

F-5  
34  
283

PILOT SAMPLE SHOULD BE APPROVED BY A H S P BEFORE BULK PRODUCTION.

		EST. WT. <b>0.02</b>	TO BE STAMPED OR MARKED WHERE INDICATED THUS # ( LETTERS )
		ALL SHARP EDGES AND CORNERS TO BE REMOVED UNLESS OTHERWISE STATED MACHINED CORNERS TO HAVE R OUTSIDE R INSIDE EQUIVALENT CHAMFERS ARE PERMISSIBLE.	
		MATERIAL :-	USED ON :- <b>Cb 315-659-2</b>
4A	18-8-08	D. O. CORRECTION.	
ISSUE	DATE	NATURE OF AMENDMENTS	
DRN		SCALE :- <b>2 : 1</b>	CONTROLLERATE OF QUALITY ASSURANCE (HEAVY VEHICLES) <b>AVADI</b>
		DIMENSIONS IN mm	
CHD		TOLERANCE ON DIMENSIONS UNLESS OTHERWISE STATED IS : 2102 - 69	TITLE :- <b>INCREASING CORRECTION OF MOMENT ASSY.</b>
APPD		ALL THREADS TO CONFORM TO	
DATE	<b>13/3/07</b>	D S CAT NUMBER	DRAWING NUMBER <b>Cb.315-660-35</b>
SIZE A4			



