

DRG. NO. :-

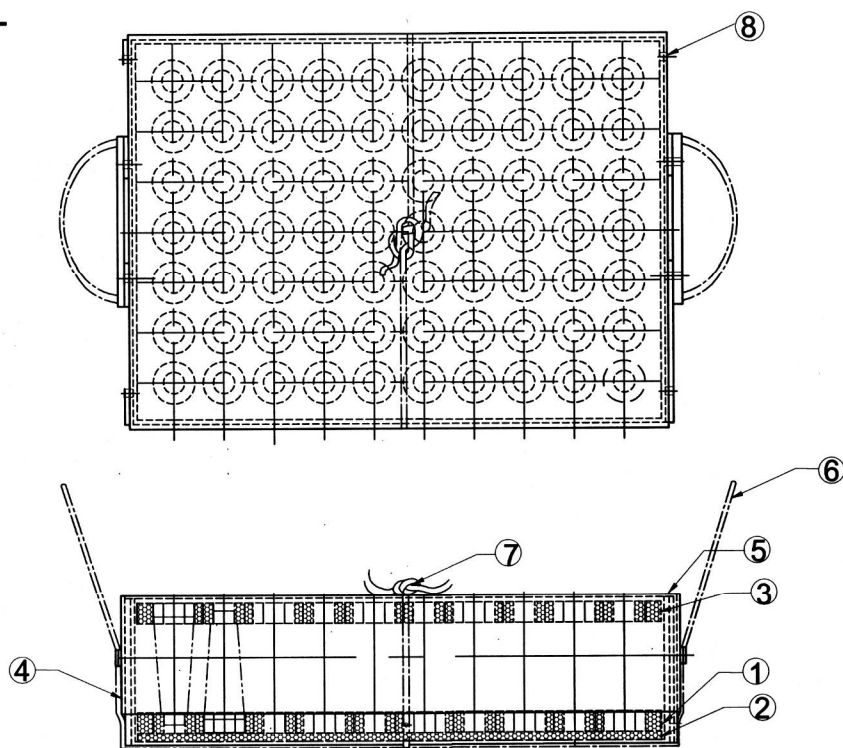

GENERAL ARRANGEMENT

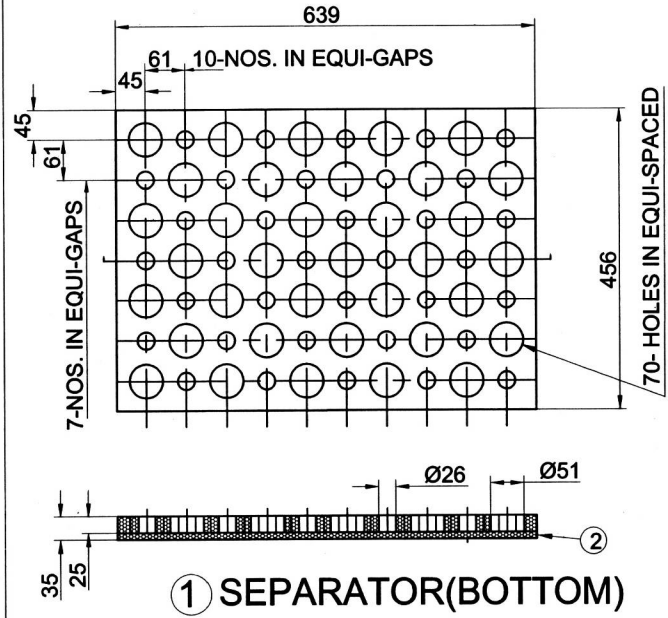

1 SEPARATOR(BOTTOM)

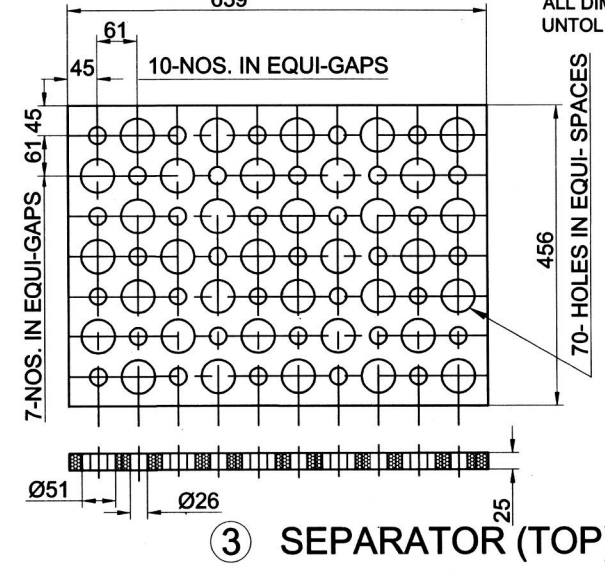

3 SEPARATOR(TOP)

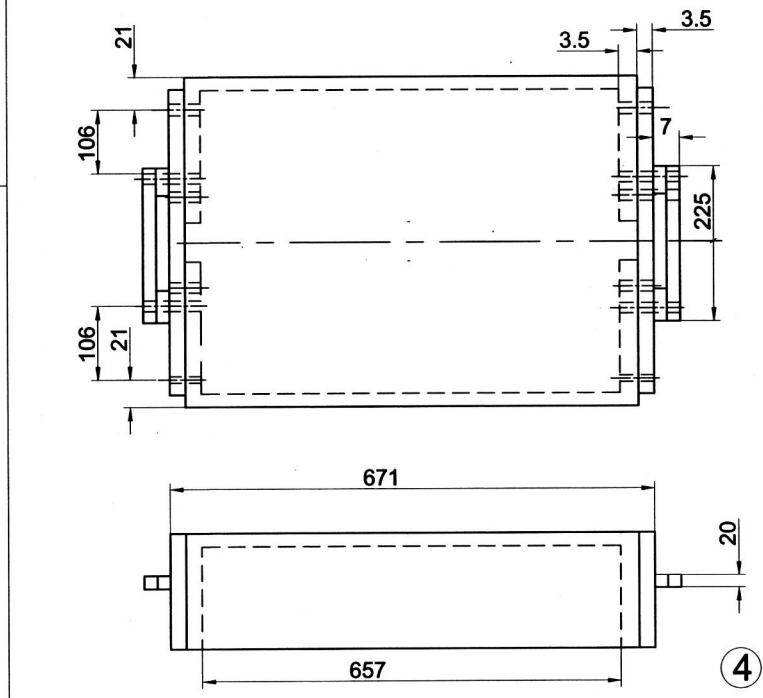

4 BOX(TOP/LID)

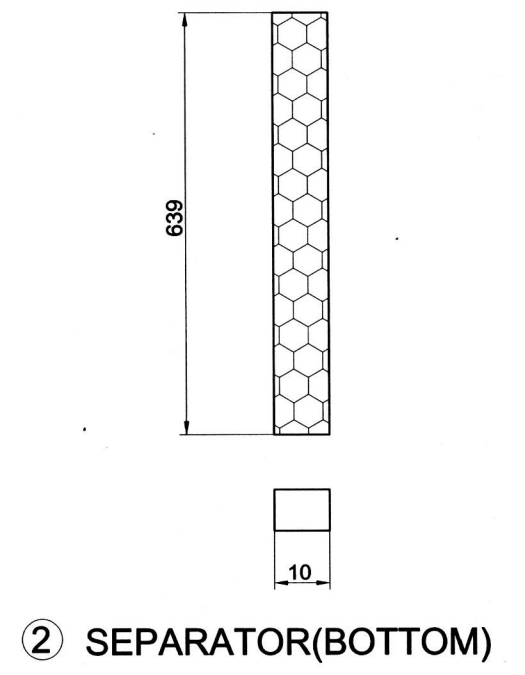
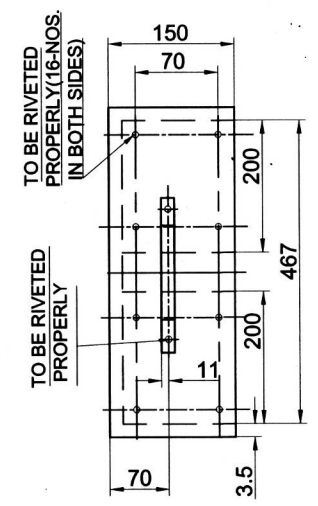

2 SEPARATOR(BOTTOM)

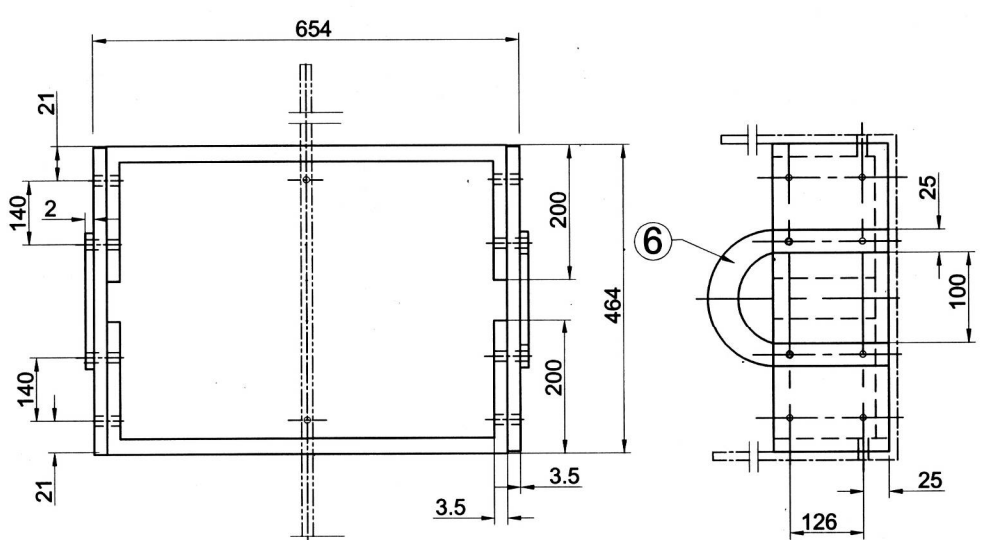

5 BOX(BOTTOM)

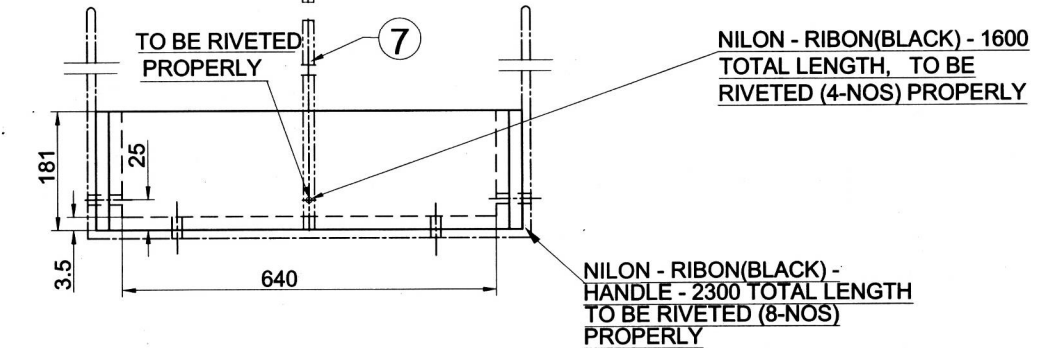

**NOTE :- (MATL. SPECN):-**  
 FOR BOX (TOP & BOTTOM) :- HIGH IMPACT CO - POLYMER OF POLYPROPYLENE CORRUGATED SHEET OF 3.5mm. THICKNESS & DENSITY OF 900-1100 IN YELLOW COLOUR.  
 FOR SEPQRATOR :- EXPANDED P.E. FOAM WITH DENSITY OF 20-35 Kg/m<sup>2</sup> HAVING TENSILE STRENGTH OF 1.5-3.5 Kg / (TRANSVERES DIRECTION). 2.5-5.0 Kg /CM<sup>2</sup> .(MACHINE DIRECTION AS PER IS: 7888

ITEM NO.	NO. OFF	DESCRIPTION	MATERIAL
8	38	RIVET	STD
7	1	RIBON (TOTAL LENGTH 1600 )	NILON
6	1	RIBON HANDLE (TOTAL LENGTH 2300 )	NILON
5	1	BOX(BOTTOM)	POLYPROPYLENE
4	1	BOX(TOP)	POLYPROPYLENE
3	1	SEPARATOR	P.E. FOAM
2	1	SEPARATOR	P.E. FOAM
1	1	SEPARATOR	P.E. FOAM

LIST OF PARTS

DRG. DESING & DIMN. CHANGE AS DESIRED BY JWM/SHELL(M) VIDE MEMO NO. 107/072/Gdn/40/06/Drg.DL24/11/14	SCHEDULE NO.:	COMPT-51mm MORTAR BOMB BODY HE	STORE DRG NO ITV- 17 SA
	SCALE: NTS PROJECTION THIRD ANGLE		
	DRAWN BY: J. Halder 12/01/15	PACKING BOX FOR	
	CHECKED BY:		
	APPROVED BY: J. Halder 12.01.15	DRG. NO. :- CO - 454 B	
	CONCURRED BY: JWM SPC(M)		
DT. & SG.	DESCRIP	M / C :	NO. OF SHTS.
AMENDMENTS	DATE: 12/01/15 SIGN: J. Halder	G. & S. FY. COSSIPORE	SHT. NO. :

DRAWN AS PER MEMO NO.107/072/Gdn/40/06/Dgn. Dt. 24/11/2014