

DRAWING NUMBER  
172.56.009-5

SHEET NO. 1 OF 1

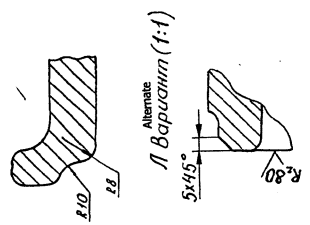
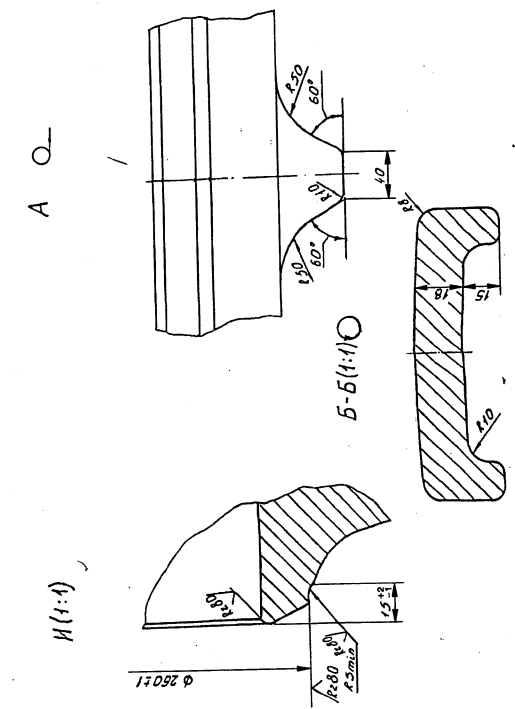
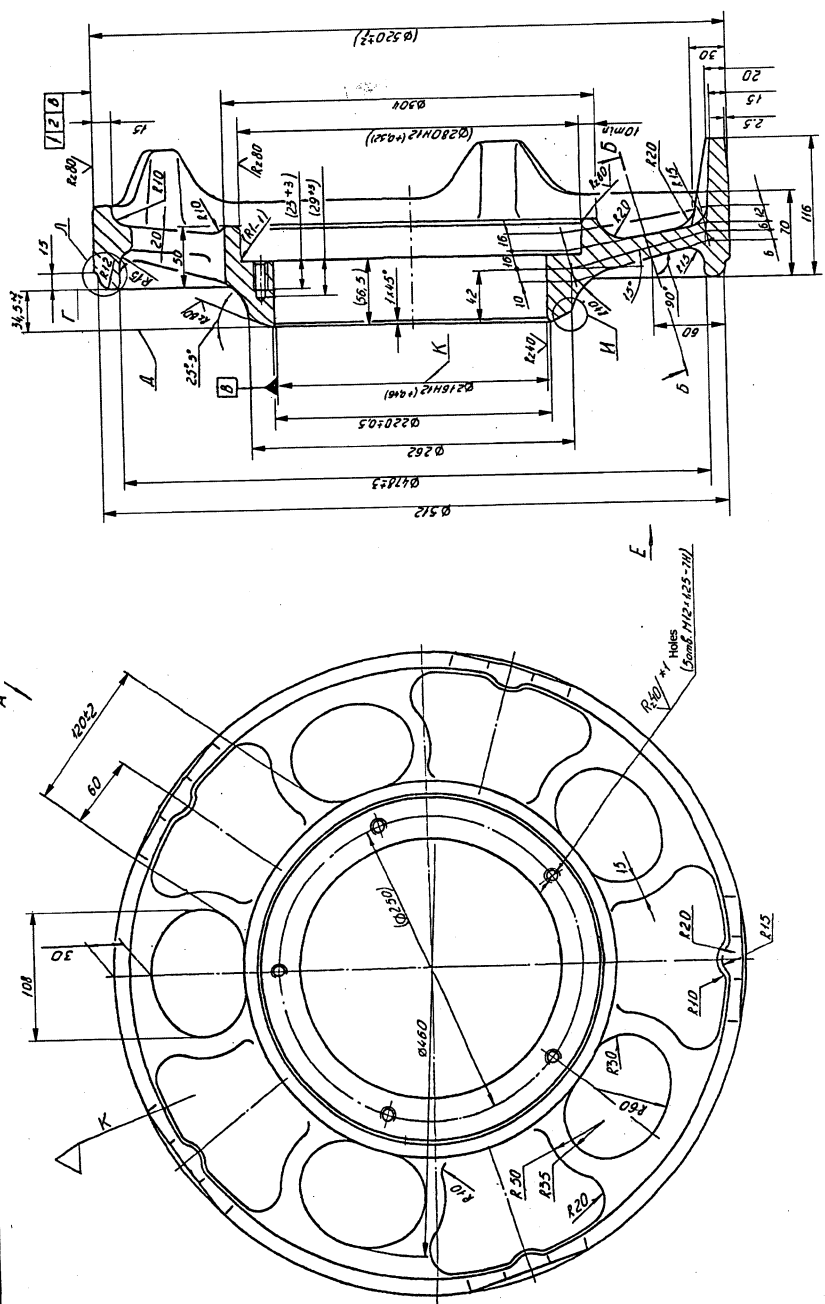

1. Grade of steel, heat treatment, method of acceptance and tests as per the list of parts made from special steel. Medium hardness.
2. Requirement for casting are as per 172.TY.6.
3. Accuracy of casting 11-0-0-10 GOST 28845-85.
4. External draft: 1:20.
5. Unspecified radii: R10.
6. Dimension K with  $\rightarrow$  should be ensured on length  $10^{+0.05}$  mm from the side of face J, on remaining surface  $20 \pm 0.15$  mm with surface finish  $\rightarrow$ .
7. Dimensions in brackets after assembly.
8. Dimensions in brackets after assembly.
11. Other requirements are as per 500.TY.1.
13. \*Surface finish to be ensured by tool.

ITEM NO.	QTY	UNIT	DESCRIPTION	MATERIAL
1	1	PC	INNER DISK	SPECIAL STEEL
CONTROL REQUIREMENTS OF QUALITY ASSURANCE (HEAVY VEHICLES)				
AVADI				
TITLE:				
D & CAT NUMBER				
DRAWING NUMBER				
172.56.009-5				

TEST SAMPLE SHOULD BE APPROVED BY A R S P BEFORE BULK PRODUCTION.  
TEST WPT 960 TO BE STAMPED OR MARKED WHERE INDICATED THIS # ( LETTERS)  
40.00  
ALL SHARP EDGES AND CORNERS TO BE REMOVED UNLESS OTHERWISE STATED  
SIDE R INSIDE EQUIVALENT CHAMFERS ARE PERMISSIBLE.