

765-38-6141

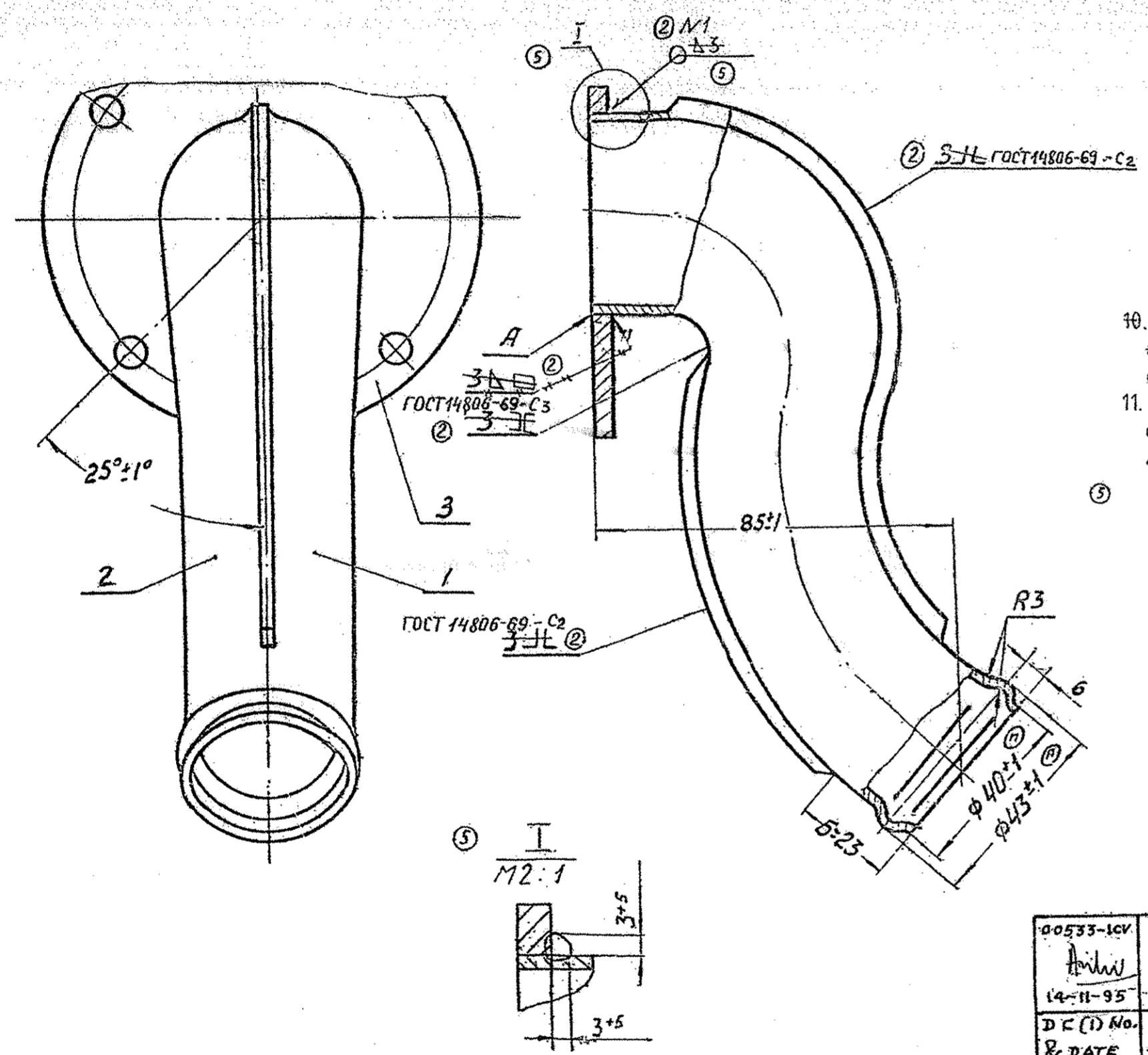

- 10. Bakelite coating may be applied all around followed by painting on the outside.
- 11. Non-squareness of straight section of pipe with respect to surface A should not exceed 2mm over a length of 50mm.

- 1. Dress weld flush on section B.
- 2. Carry-out argon arc welding of weld N1.
- 3. Perform leakage test with water at a pressure of 0,2 kg/cm². Leakage is not allowed. Leakage test may be performed with air at a pressure of 0,5kg/cm² in water bath
- 4. Provide dimensions without deviations with an accuracy of ±0,5mm.
- 5. Non-flatness of surface A should not exceed 0,5mm.
- 6. Sinking of pipe beyond surface A should not exceed 1mm. Projection is not allowed.
- 7. Apply primer φЛ-03 GOST 9109-81 on the pipe external surface and paint with enamel нФ-223, white-1, GOST 14923-78.
- 8. Coating: anodic oxidation, chromating or chemical, parkerizing blue.
- 9. Apply two coats of bakelite varnish, grade Л6с-1 GOST 901-78, inside the pipe as per instructions -053.25273.00010.

Ref. No.	Designation	Description	Qty	Remarks
		Bakelite varnish		
		White-1		
		Enamel нФ-223		
		Primer φЛ-03-1K		
3	765-38-155	Flange	1	
2	765-38-84	Branch pipe, half	1	
1	765-38-83	Branch pipe, half	1	

00533-1CV	DRG. AMENDED BASED ON APPROVAL OF 4/94 N. OF A
14-11-95	ISSUE NATURE
DC (D) No. & DATE	AMENDMENTS

ALL SHARP EDGES & CORNERS TO BE ROUNDED OFF	ALL THREADS TO CONFORM TO SPECIFICATION	STAMP OR ETCH, PART NO. MANUFACTURERS NAME & YEAR OF MFG.
DRG. NOT TO BE SCALED	TOLERANCE ON DIMENSIONS UNLESS OTHERWISE SPECIFIED	USED ON: 675-38-C63
SCALE: 1:1	WT: 0.180 (Kgf)	
DATE: 20-10-95		
DRN. 14/11/95		
TCD. 14/11/95		
CHD. 14/11/95		
APD. 14/11/95		
PIPE		
765-38-C6141		
CONTROLLERATE OF QUALITY ASSURANCE (INFANTRY COMBAT VEHICLES)		

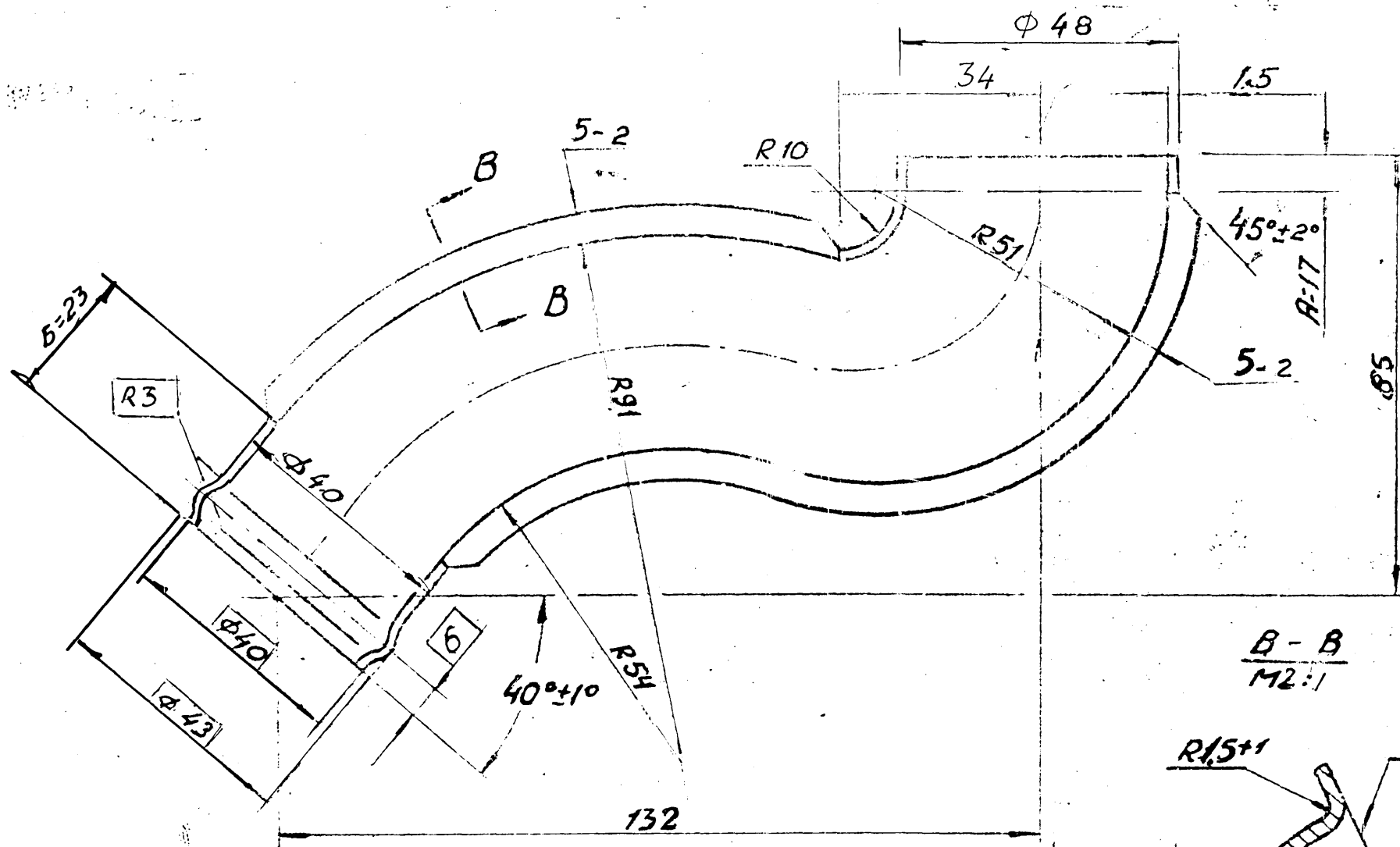

1. Blunt sharp edges.
2. Dimensions without deviations with accuracy of ± 0.5 upto 80 and ± 1 above 80
3. Maintain dimension $\phi 48$ on section A=17 and maintain dimension $\phi 40$ on section B=23.
4. Maintain dimensions given in \square in assembly.
5. Non-flatness of surface Γ not exceeding 1 mm is allowed.
6. EQ. MATERIAL :- ALUMINIUM SHEET Gde. 31000 TO IS: 737-74.

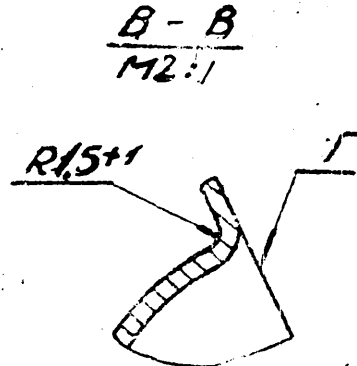

00533-1CV <i>fulw</i> 14-11-95	(A) <i>fulw</i>	DRG. AMENDED BASED ON APPROVAL OF A/94 N OF A
DC(1) No. & DATE	ISSUE	NATURE
AMENDMENTS		

MATERIAL	SHEET AMUM 1.5	GOST 21631-76.
DRG. NOT TO BE SCALD		
SCALE :-	1:1	
DATE :-	20-10-95	
DRG. <i>fulw</i>		
TCD. <i>fulw</i>	0.032	
CHK. <i>fulw</i>		
APP. <i>fulw</i>		
765-38-C8141		
BRANCH PIPE HALF		
765-38-83		
CONTROLLED BY		
(INFINITY CONTROL)		

48-85-502

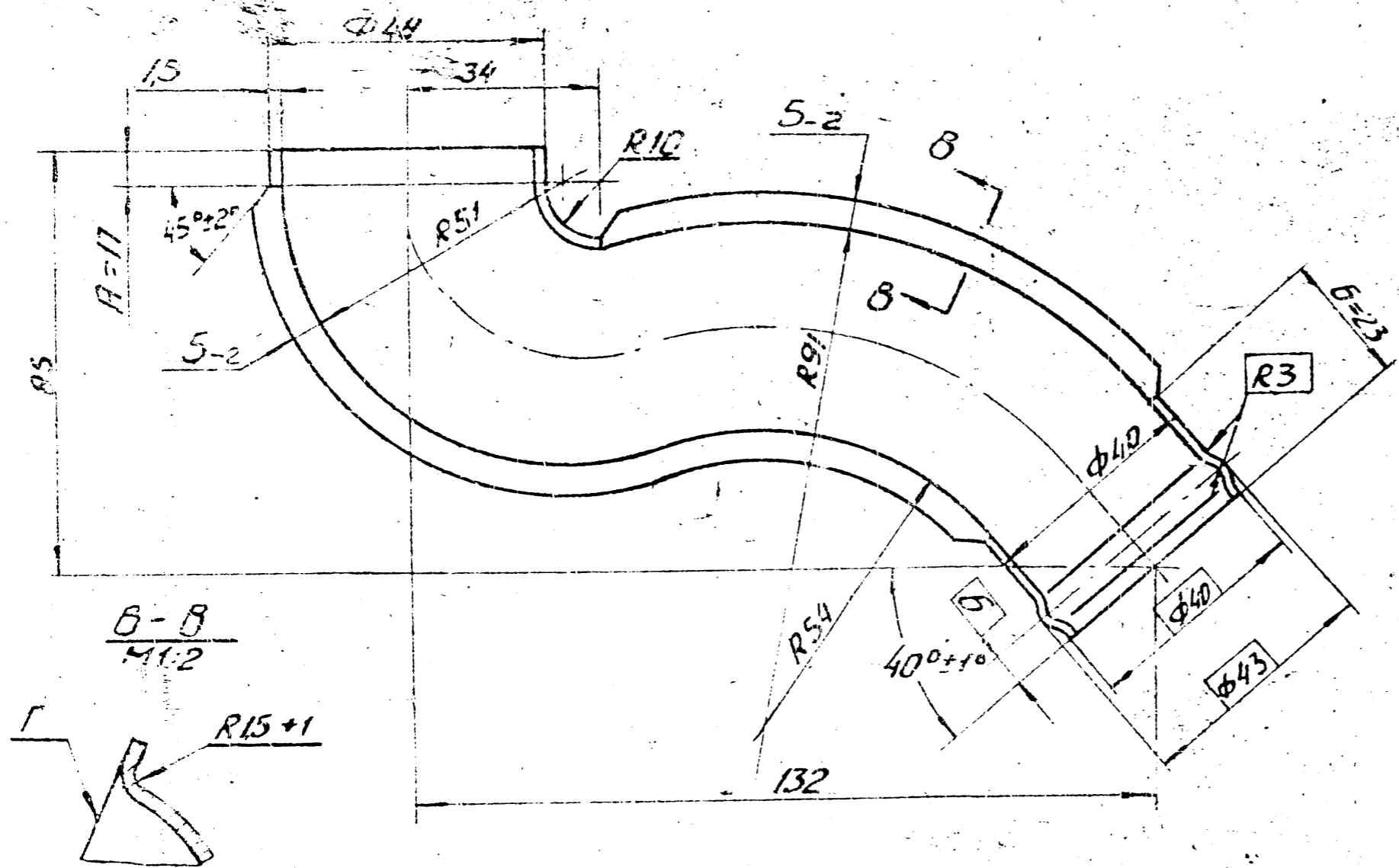

1. Blunt sharp edges.
2. Perform dimensions without deviations with accuracy of $\pm 0,5$ upto 80 and ± 1 above 80.
3. On section $A=17$ maintain dimensions $\phi 48$, on section $B=23$ maintain dimension $\phi 40$.
4. Maintain dimensions given in in assembly
5. Non-flatness of surface Γ not exceeding 1 mm is allowed.
6. EQ. MATERIAL :- ALUMINIUM SHEET - Gde. 31000 TO IS: 737-74.

00533-1CV <i>Atulw</i> 14-11-95	① <i>Atulw</i>	DRG. AMENDED BASED ON APPROVAL OF 4/94 N OF A
DC (I) No. & DATE	ISSUE	NATURE
AMENDMENTS		

MATERIAL :- SHEET AM4M-1.5 GOST 21631-76.	
ALL SHARP EDGES & CORNERS TO BE ROUNDED OFF	ALL TOLERANCES UNLESS OTHERWISE SPECIFIED
ORG. NOT TO BE SCALED	
SCALE :- 1:1	TOLERANCE ON DIMENSIONS :- SS OTHERWISE SPECIFIED
DATE :- 20-10-95	765-38-C6 141
DRN. <i>Pathak</i>	WT :- ()
TCD. <i>10</i>	0.032
CHD. <i>Atulw</i>	
APD. <i>Atulw</i>	

BRANCH PIPE HALF

765-38-84

CONTROLLERATE OF QUALITY CONTROL
(INFANTRY COMBAT VEHICLE)

765-38-155/156

(A) 2

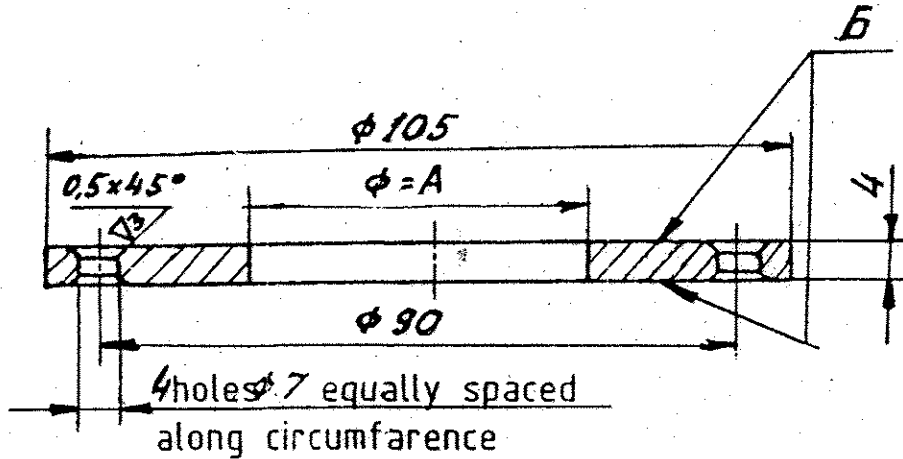

1. Blunt sharp edges.
2. Provide dimensions without deviations as per accuracy class 7 OST-1010.
3. Deviations of centres of holes from their true position should not exceed 0,2mm.
4. Non-flatness of surfaces B should not exceed 0,5mm.
5. Stamping drafts should not exceed 0,4mm.
6. Alternate material is sheet AMГ5M, GOST 21631-76.
7. EQ. MATERIAL: ALUMINIUM SHEET G.de-55000 TO IS: 737-74.

00533- REV 14-11-95 DCC No & DATE	(A) 88	DRG. AMENDED BASED ON APPROVAL OF 4/94 N OFA	Designation	A	Weight
	ISSUE	NATURE	765-38-155	49	0,071
			765-38-156	43A7 ^{+0.62}	0,075
AMENDMENTS					

MATERIAL: SHEET AMГ5M-4, GOST-21631-76.		
ALL SHARP EDGES & CORNERS TO BE ROUNDED OFF	ALL THREADS TO CONFORM TO SPECIFICATION	STAMP OR ETCH, PART NO. MANUFACTURERS NAME & YEAR OF MFR.
DRG. NOT TO BE SCALED	TOLERANCE ON DIMENSIONS UNLESS OTHERWISE SPECIFIED	USED ON: 765-38-C6141 675-38-C6107
SCALE: 1:1	DRN. <i>Latthal</i>	FLANGE
DATE: 20-10-95	WT: (Kg) SEE TABLE	
CHD. <i>JE</i>		765-38-155/156
APD. <i>Julw</i>		
CONTROLLERATE OF QUALITY ASSURANCE (INFANTRY COMBAT VEHICLES)		