

6 5 4 3 2 1

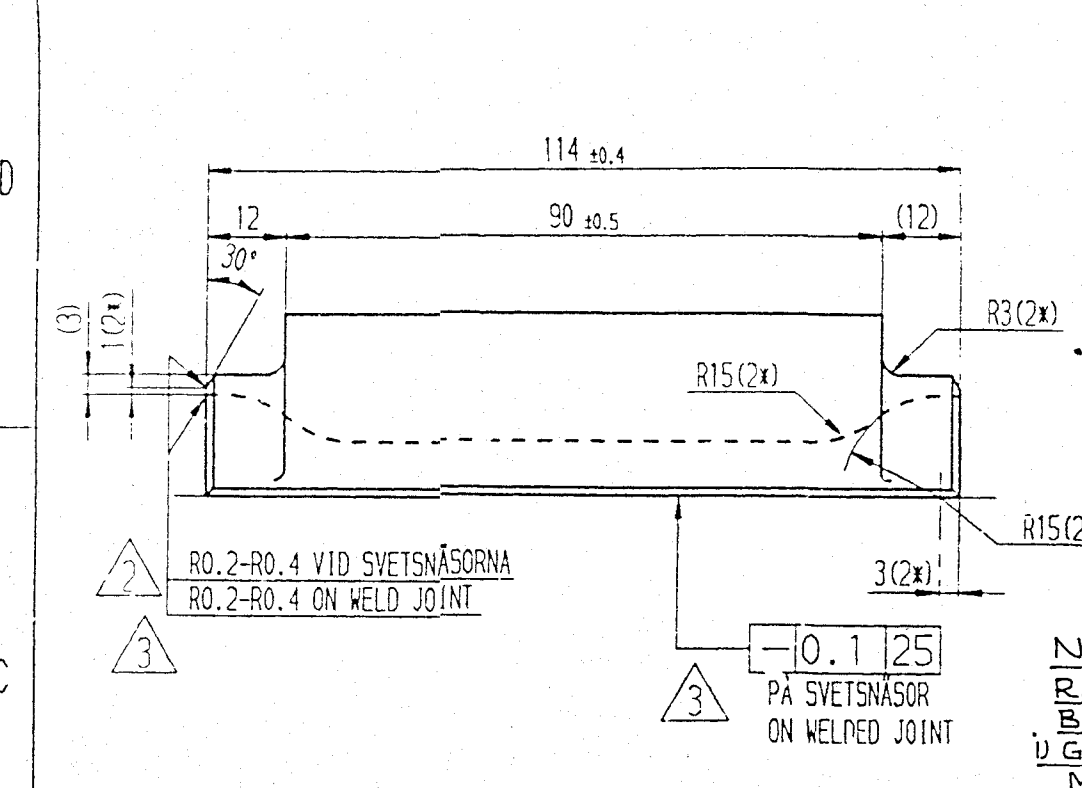

ALT MATL :-
BS:31416-PE 1-74 TYPE CLA-4 HEAT
TREATED TO ACHIVE HARDNESS
245-290 HB

Toleranser enligt ISO		Tolerances acc. to ISO	
Resultat av tolerans	Gränsvärde	Limit deviation	
Basic size and tolerance	Basic size	Upper	Lower

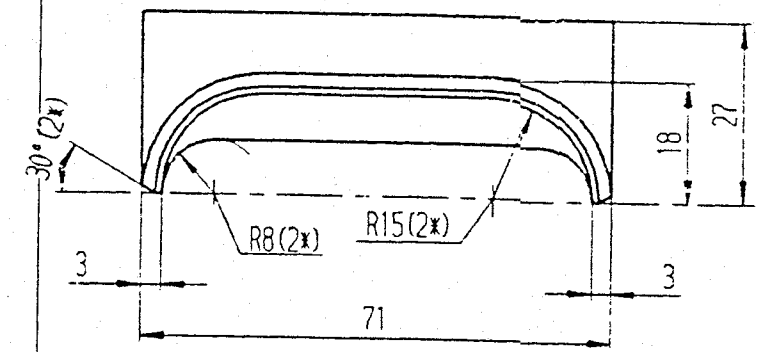

DHANUSH

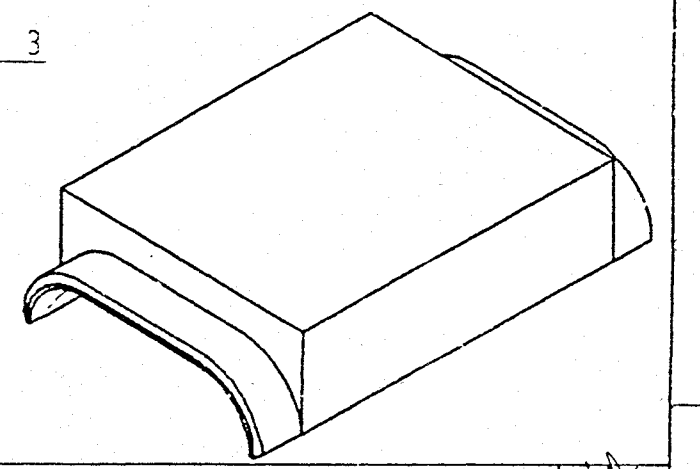

NOTE :-
RADIOGRAPHIC EXAMINATION SHALL
BE AS FOLLOWS :-
1) GAS HOLES AND FOREIGN MATERIAL - LEVEL 5 AS PER ASTM E-192
2) SHRINKAGE (ALL TYPES) - LEVEL 3 AS PER ASTM E-192

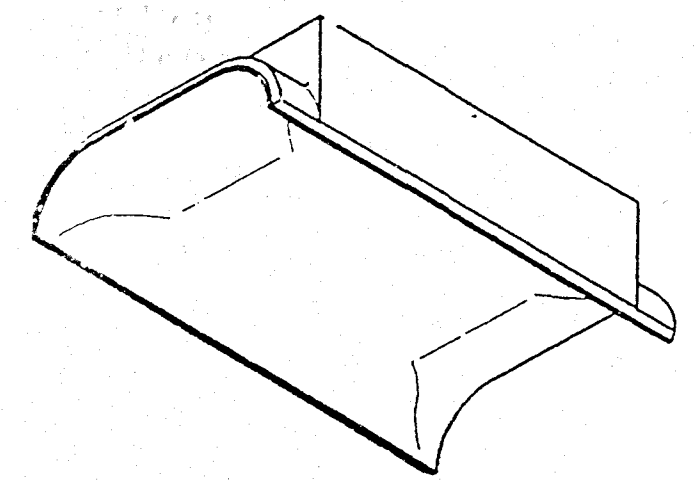
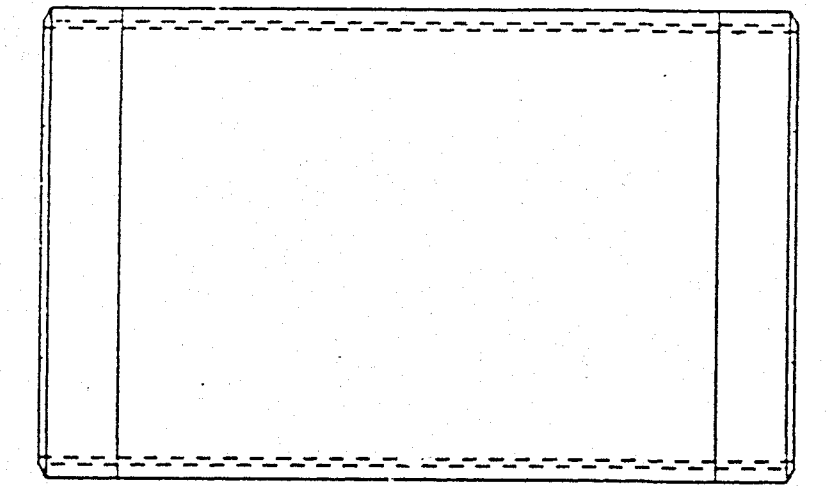

TOLERANS ENLIGT SS-722 G1A 13 DÄR EJ ANNAT ANGES
TOLERANCE: SS-722 G1A 13 UNLESS OTHERWISE STATED
KONTR.o.LEVERANS BESTÄMMELSE A 2017
INSPECTION AND DELIVERY SPEC. A 2017
HANDELSKVALITET
COMMERCIAL QUALITY
RÖNTGEN ENDAST AV UTFALLSPROV
X-RAY FIRST PART SAMPLES ONLY

18526-W 8-7-98	NOTE ADDED	
18499-W 26-12-98	ALT MATL ADDED & COMP MATL DELETED	
17018-W 15-2-91	COMP MATL ADDED.	
13-1-89	16724-W	DRG SEALED PROV.

3	C6, C5	39038895, RO.2-RO.4 VAR MAX RO.2, RAKHET TILLK.	860521	KL5G
2	C6	35036651, TEXT TILLKOMMER	851009	KL5G
1		39035276, FIGUR RITAD	850827	KL5G
Änd. nr Rev. No.	Läge Zone	Ändringsbeskrivning Revision order No. and description of the revision	Datum Date	Godkänd Approved

Där ej annat angetts gäller		Unless otherwise stated the following applies		Titel Title	Beställning Designation
Skarpa kanter brutna Sharp edges broken	0,5 - 1,5 ANDS	Kontroll Checked	KL5G	SS-2225-24	Ytstånd Condition
Ytjämnhet R _a på Surface roughness R _a on	12	Års. Dept. VT-11	850827	Utgångsvärde Basic material	Skala Scale
Toleranser för klipp och gästning enligt T2-3	Skärningslinjer enligt T2-2 klass Machining tolerances acc. to T2-2 class	Skala Scale	1:1	Ändringsritning Previous drawing	Ytikt Weight kg
Toleranser för slipning och flåskutt. acc. to T2-3	Svetslinjer enligt T2-4 klass Welding tolerances acc. to T2-4 class	Proj. metod	1:1	Ytplacerad Previous drawing	Ytikt Weight kg
Toleranser för ytbehandling	Ytbehandling	Proj. metod	1:1	Ytplacerad Previous drawing	Ytikt Weight kg
Benämning PLATTA, PREC.GJUTET ÄMNE		Ytning nr Drawing No.	5.173 820	Senaste ändr. Latest rev.	
Benämning PLATE, INVESTMENT CAST MTRL.		Ytning nr Drawing No.	5.173 820	Senaste ändr. Latest rev.	

BOFORS

3

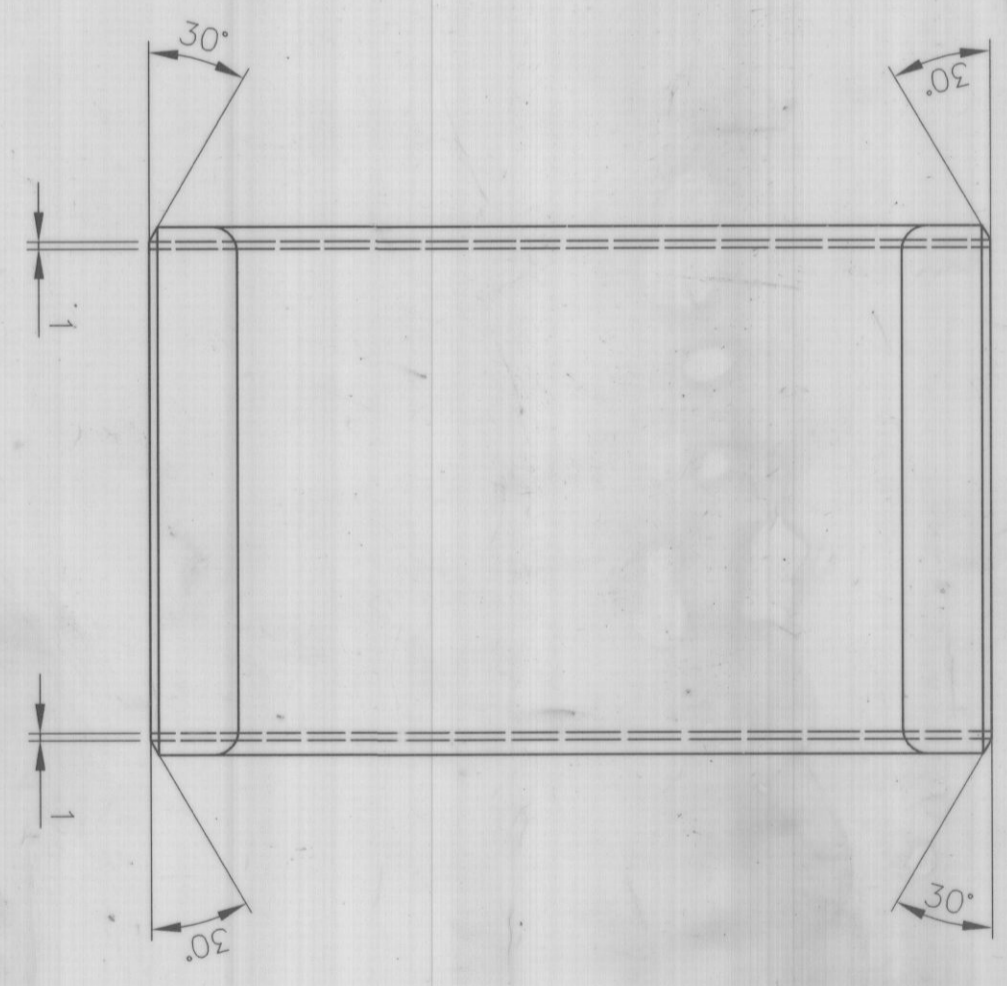
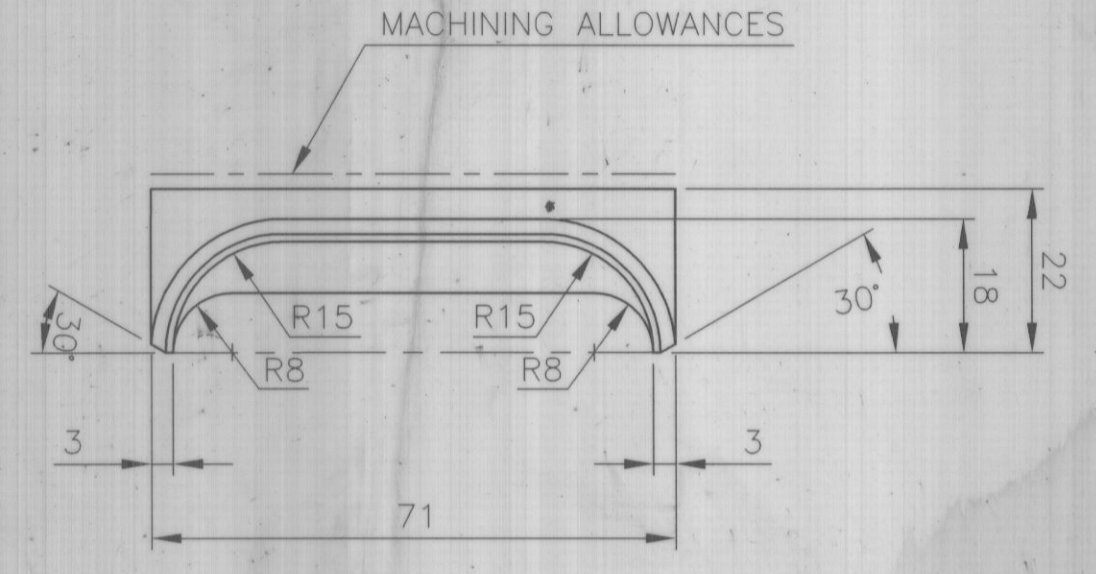
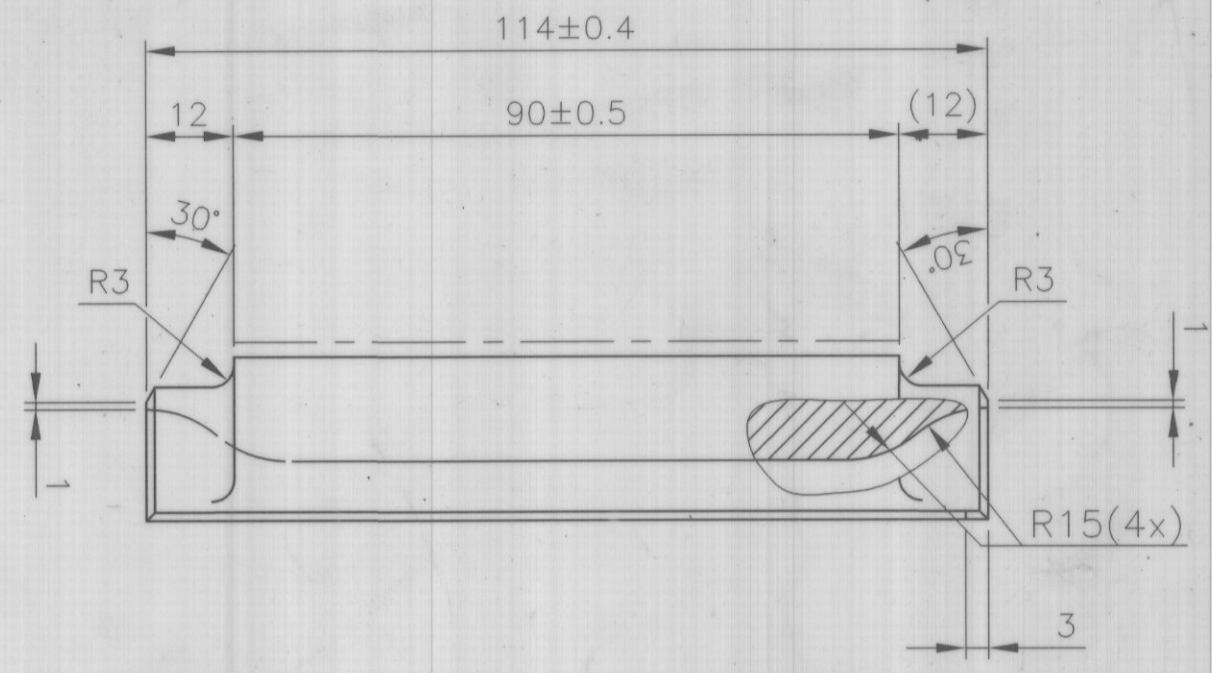

CASTING TOLERANCES ACC TO SS722 GTA 13
MANUFACTURING SPEC. : A2017, COMMERCIAL QUALITY,
EXCEPT X-RAY TESTING.

MATL. - IS: 10843-1999, Grade B B, LOND
'BT' with 1/8" P each 0.035 max
TO achieve R_{max} = 600 MPa min,
R_m = 800-950 MPa, EL = 10%, HB = 235-285
FOR CASTING SEE DRG. No. S173820

SURFACE ROUGHNESS μm 25/

P.No.	NOMENCLATURE	No. OFF	MATERIAL	HARDNESS	STANDARD	REMARKS
						FOR Sr. GM G.C.Fy.
					2015	NAME DATE
						DRN. SANJAY 06/08
						CKD. S.K.JAIN 16/09
	INDEX	AMENDMENTS	SIGN	DATE	APPROVED	
			MATERIAL		SS 2225-24	
			SCALE		REF.DRG.NO.	
			ASSY/SUB ASSY NO.		1144027	
			DRG. No. 4 077 475		SHEET NO. OF SHEETS	
			GUN CARRIAGE FACTORY, JABALPUR			

PLATE

- ~ UNMACHINED
- ▽ ROUGH
- ▽▽ SMOOTH
- ▽▽▽ FINISH

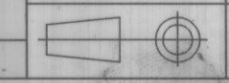

GUN CARRIAGE FACTORY, JABALPUR