

DRG No. 02040304020400DA  
 IC SS C AA C SS IC  
 02040304020400DA  
 C A AA C SS IC

GENERAL TOL. : FINE / MEDIUM / COARSE CLASS TO IS: 2102  
 DRG. CONVENTIONS CONFIRM TO INDAN STANDARDS DIMENSIONS ARE IN mm UNLESS OTHERWISE STATED.

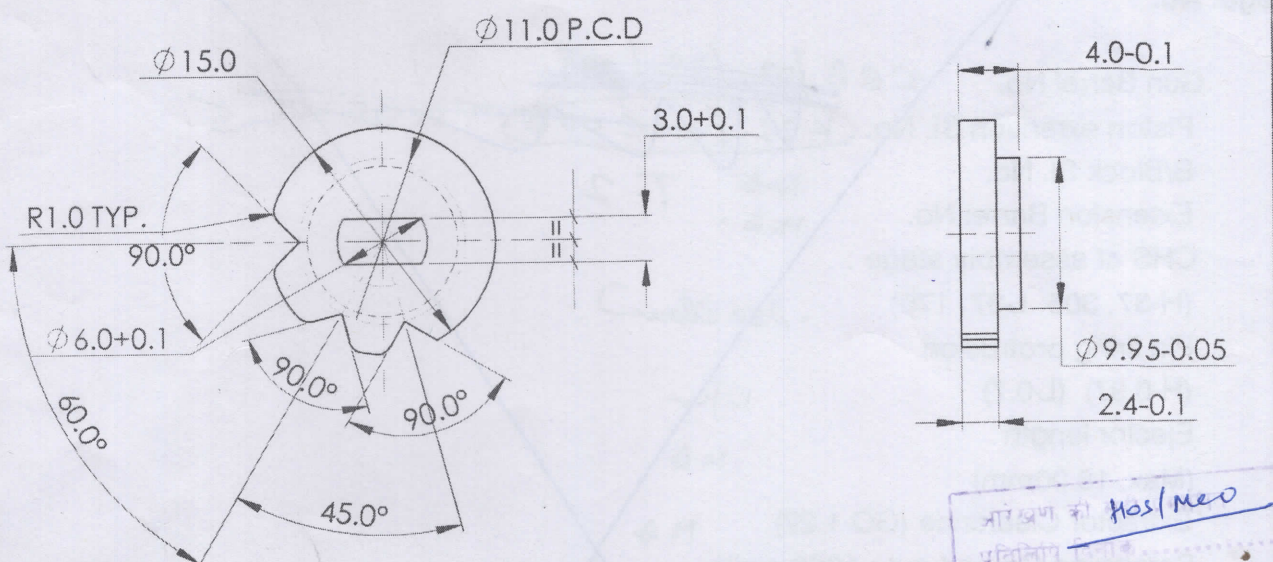

**NOTES:-**

- 1) REMOVE ALL SHARP EDGES AND BURRS.
- 2) TOLERANCE FOR ANGLES  $\pm 30'$  UNLESS OTHER STATED
- 3) HARDNESS : 500 TO 550 H.V.
- 4) HEAT TREATMENT : CASE HARDENED TO A DEPTH OF 0.13 TO 0.26
- 5) IF THE COMPONENT IS TO BE MANUFACTURED THROUGH MIM ROUTE, REFER ARDE SPECN No. DRDO/ARDE/MIM/TSP/051/2019.
- 6) ALT. PROTECTIVE COATING: PHOSPHATED TO SPECN. IS: 3618-1966, CLASS 'B'

जांचणा की Hos/Meo  
 प्रमाणित किया  
 Certified as correct copy  
 of drg. on 15/12/22  
 Sr. Works  
 STANDARD CELL

Sr. No.	DATE	AUTHORITY	BRIEF RECORD	ZONE	CD	GO
					SIGN	

DRN: SOURABH  
 SIGN: *[Signature]*  
 DATE: 07/03/2019  
 MATERIAL: STEEL TO IS: 4432, 1988 Gr. 13Ni13Cr3  
 PROTECTIVE FINISH: ELECTROLESS NICKEL-BORON NITRIDE(NiBN) COATING AS PER ARDE SPECN. NO: ARDE/SA/2016/COATING-02  
 APPD. *[Signature]*  
 DATE: 07/03/2019 FOR DIRECTOR  
 SHEET SIZE: A4  
 SCALE: 2:1  
 EST. MASS 3.48gm  
 DESIGN AUTHORITY  
**ARDE**  
 PUNE 411021  
**WHEEL LOCK**

DRG No. 02040304020400DA  
 IC SS S AA A C SST

JVPC PART No. DS CAT No. AHSP