

PLACE FOR IDENTIFICATION LABEL (1"x6") TO BE PLAIN MACHINE STITCHED WITH MATERIAL 'e', AND TO BE MARKED PART NAME, PART No., SERIAL No., DATE OF MANUFACTURE AND INSPECTOR'S STAMP.

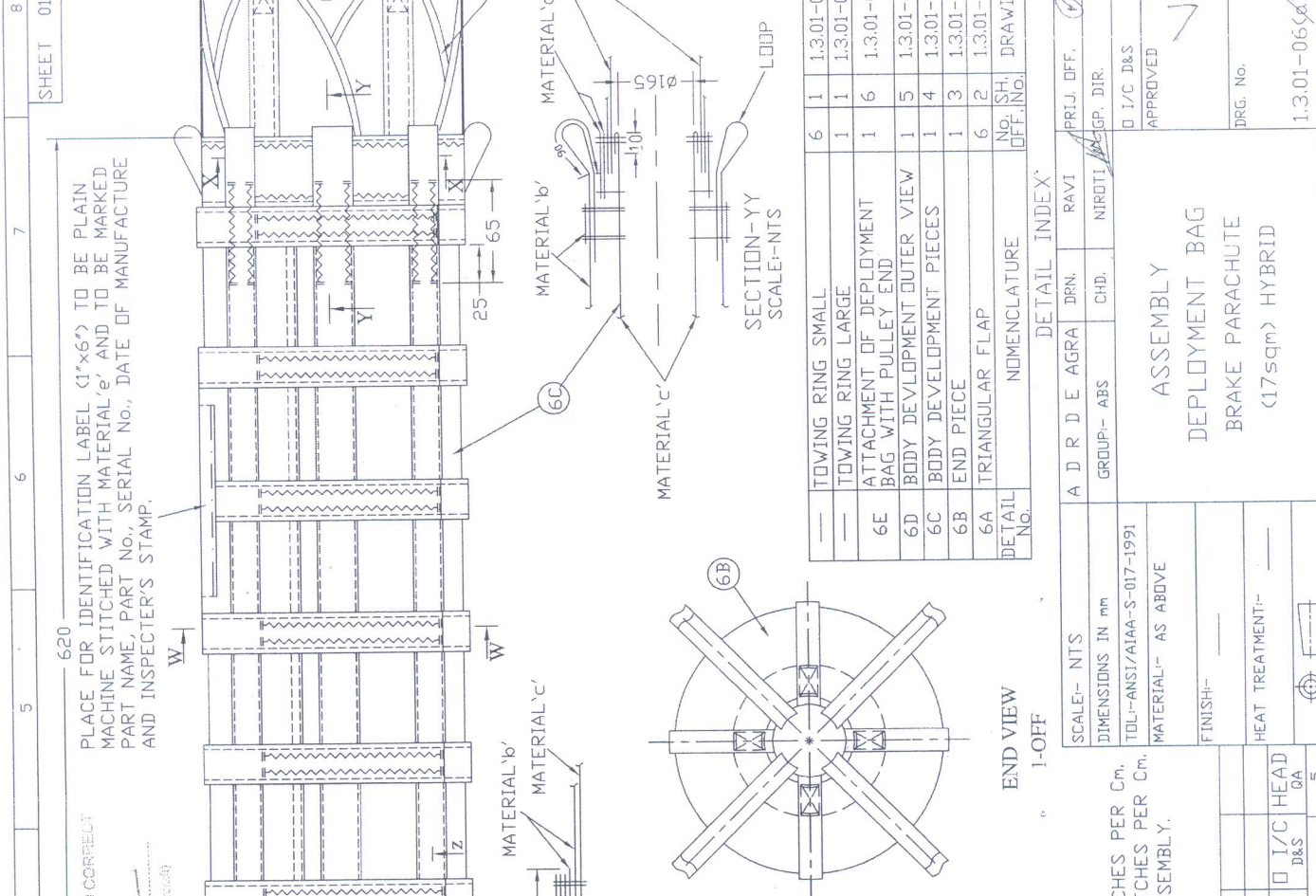

END TO BE SEALED WITH MATL 'm' OVER LAPPED PORTION OF MATL 'b' TO BE TWO ROWS ZIG-ZAG STITCHED WITH MATERIAL 'e' 3-4 STITCHES PER CM.

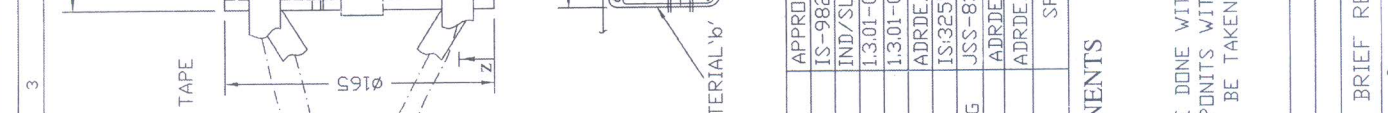
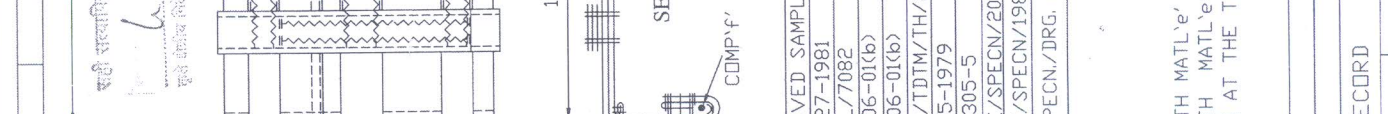

DETAIL No.	DESCRIPTION	QTY	DRG. No.
6	TOWING RING SMALL	1	1.3.01-06-01(k)
1	TOWING RING LARGE	1	1.3.01-06-01(k)
1	ATTACHMENT OF DEPLOYMENT BAG WITH PULLEY END	1	1.3.01-06 (b)
1	BODY DEVELOPMENT OUTER VIEW	1	1.3.01-06 (b)
1	BODY DEVELOPMENT PIECES	4	1.3.01-06 (b)
1	END PIECE	3	1.3.01-06 (b)
6	TRIANGULAR FLAP	2	1.3.01-06 (b)
	NOMENCLATURE		
	DRG. No.		



IDENTIFICATION LABEL	APPROVED SAMPLE
m DENDRITE ADHESIVE	IS-9827-1981
h INK MARKING TEXTILE BLACK	IND/SL/7082
g TOWING RING SMALL, 14.5mm DIA	1.3.01-06-01(k)
f TOWING RING LARGE, 72mm DIA	1.3.01-06-01(k)
e THREAD SEWING NYLON '66' BONDED 4.5kgf	ADRDE/TDTM/TH/2009/1
d TAPE COTTON 19mm DG	IS:3255-1979
c CLOTH COTTON CLOSELY WOVEN V.No.'C' 310gsm. DG	JSS-8305-5
b TAPE NYLON 66, 26mm, BS:500kgf U/D	ADRDE/SPECN/2000/54(c)
a TAPE NYLON 43mm, BS:9000N	ADRDE/SPECN/1985/27(b)
SL/No.	SPECN./DRG. No.

SCALE- NTS	SCALE- IN mm	TOL-ANSI/AIAA-S-017-1991	MATERIAL- AS ABOVE	FINISH-	HEAT TREATMENT-
NTS	mm	S-017-1991	AS ABOVE		

REF.No.	DATE	ZONE	AUTHORITY	BRIEF RECORD	I/C HEAD DA	5

AD R D E AGRA	DRN.	CHD.	PRJ. OFF.
	RAVI	NIROTI	

GROUP- ABS	GROUP- DIR.
	I/C DBS

ASSEMBLY
DEPLOYMENT BAG
BRAKE PARACHUTE
(17sqm) HYBRID

APPROVED

DRG. No. 1.3.01-06(a)(b)

DETAIL INDEX

NOTE:-
i. ALL ENDS TO BE SEALED WITH MATL 'm'
ii. ALL PLAIN MACHINE STITCHING ARE TO BE DONE WITH MATL 'e' 3-4 STITCHES PER CM.
iii. ALL ZIG-ZAG MACHINE STITCHING ARE 3 POINTS WITH MATL 'e' 3-4 STITCHES PER CM.
iv. APPROPRIATE SHRINKAGE ALLOWANCE MAY BE TAKEN AT THE TIME OF ASSEMBLY.

LIST OF MATERIALS/COMPONENTS

END VIEW 1-OFF

SECTION-YY SCALE-NTS

SECTION-WW

SECTION-ZZ

SECTION-XX

FINISH END

STARTING END

MATERIAL 'b'

MATERIAL 'c'

MATERIAL 'g'

MATERIAL 'a'

MATERIAL 'b'

MATERIAL 'c'

LODP

COMP 'g'

COMP 'f'

25

65

10

130

165

190

620

6A

6B

6C

6D

6E

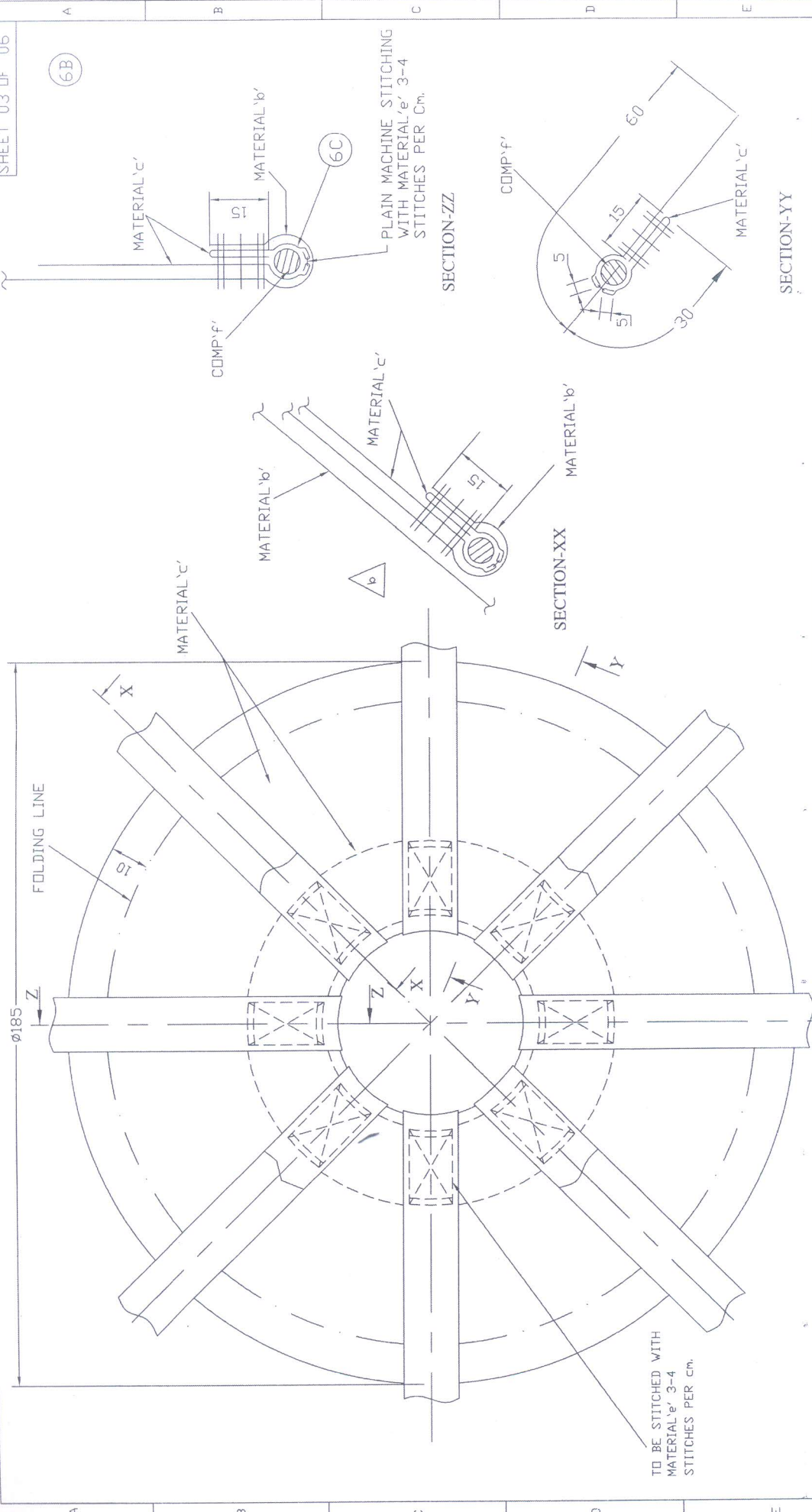

SCALE:- 1 : 1	A D R D E AGRA	DRN.	RAVI	PRJ. OFF.
DIMENSIONS IN mm	GROUP:- ABS	CHD.	NIRDTI	GP. DIR.
TOL:- ANSI/AIAA-S-017-1991	END PIECE			
MATERIAL:- AS PER SHEET -1	ASSY. DEPLOYMENT BAG			
FINISH:-	BRAKE PARACHUTE			
HEAT TREATMENT:-	(17sqm) HYBRID			

1	2	3	4	5
REF.No.	DATE	ZONE	AUTHORITY	BRIEF RECORD
b	25-9-18	3334	QMS/PG/ABS/CS/07	AMENDED AS PER CHANGE SHEET No.55
1-OFF 100% CHECKED / CERTIFIED CORRECT G. M. K.				
TO BE STITCHED WITH MATERIAL 'e' 3-4 STITCHES PER CM.				
NOTE:- ALL PLAIN MACHINE STITCHINGS TO BE DONE WITH MATL 'e' 3-4 STITCHES PER CM.				

APPROVED
D I/C D&S
DIRG. No. 1.3.01-06(6)

(6E)

1 2 3 4 5 6 7 8

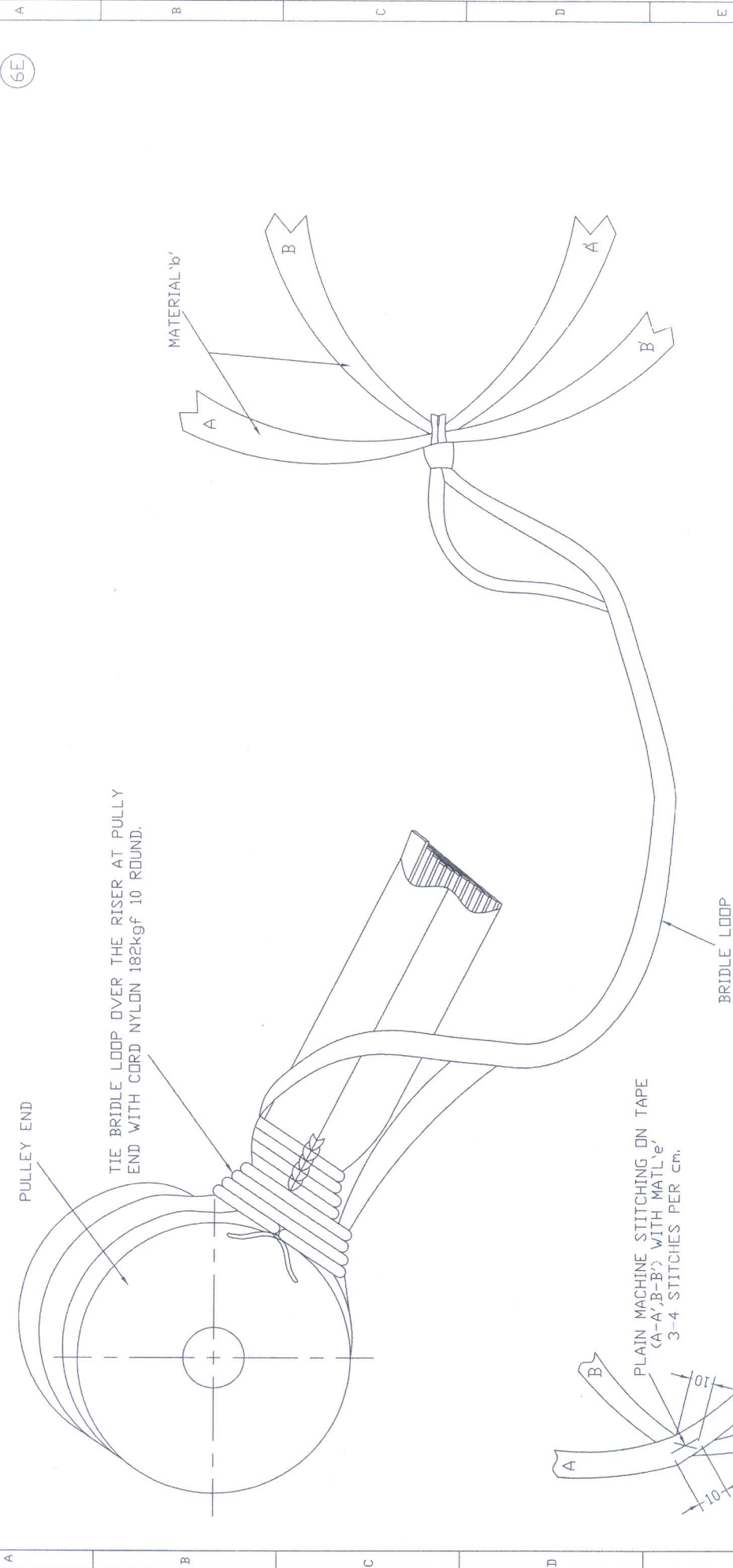

SCALE:- 1 : 5	A D R D E AGRA	DRN.	RAVI	PRJ. DFF.
DIMENSIONS IN mm	GROUP:- ABS	CHD.	NIROTTI	OP. DIR.
TOL:- ANSI/AIAA-S-017-1991	ATTACHMENT			
MATERIAL:- AS ABOVE	OF DEPLOYMENT			
FINISH:-	BAG WITH PULLEY END			
HEAT TREATMENT:-	ASSY. DEPLOYMENT BAG			
	BRAKE PARACHUTE			
	(17sqm) HYBRID			
	DRG. No. 1.3.01-06(a)(b)			
	APPROVED <i>Vinib</i>			
	I/C D&S			
	I/C HEAD			
	D&S			
	5			
	4			
	3			
	2			
	1			
REF.No.	DATE	ZONE	AUTHORITY	BRIEF RECORD

G. M. hu