

FOR EXPLANATION OF DIMENSIONING ETC, SEE CQA(I) GUIDE No. 001-1992.
 DIMENSIONS ARE IN mm
 THIRD ANGLE PROJECTION

D.C. (I): 0630-I(P), 3113-I, 3411-I, 3601-I, 4137-I, 5703-I, CHECKED FOR QM

5751-I, 5876-I.

6-SAWCUTS 0.5 WIDE x 6.0 DEEP EQUALLY SPACED IN PAIRS AS SHOWN IN POSITION

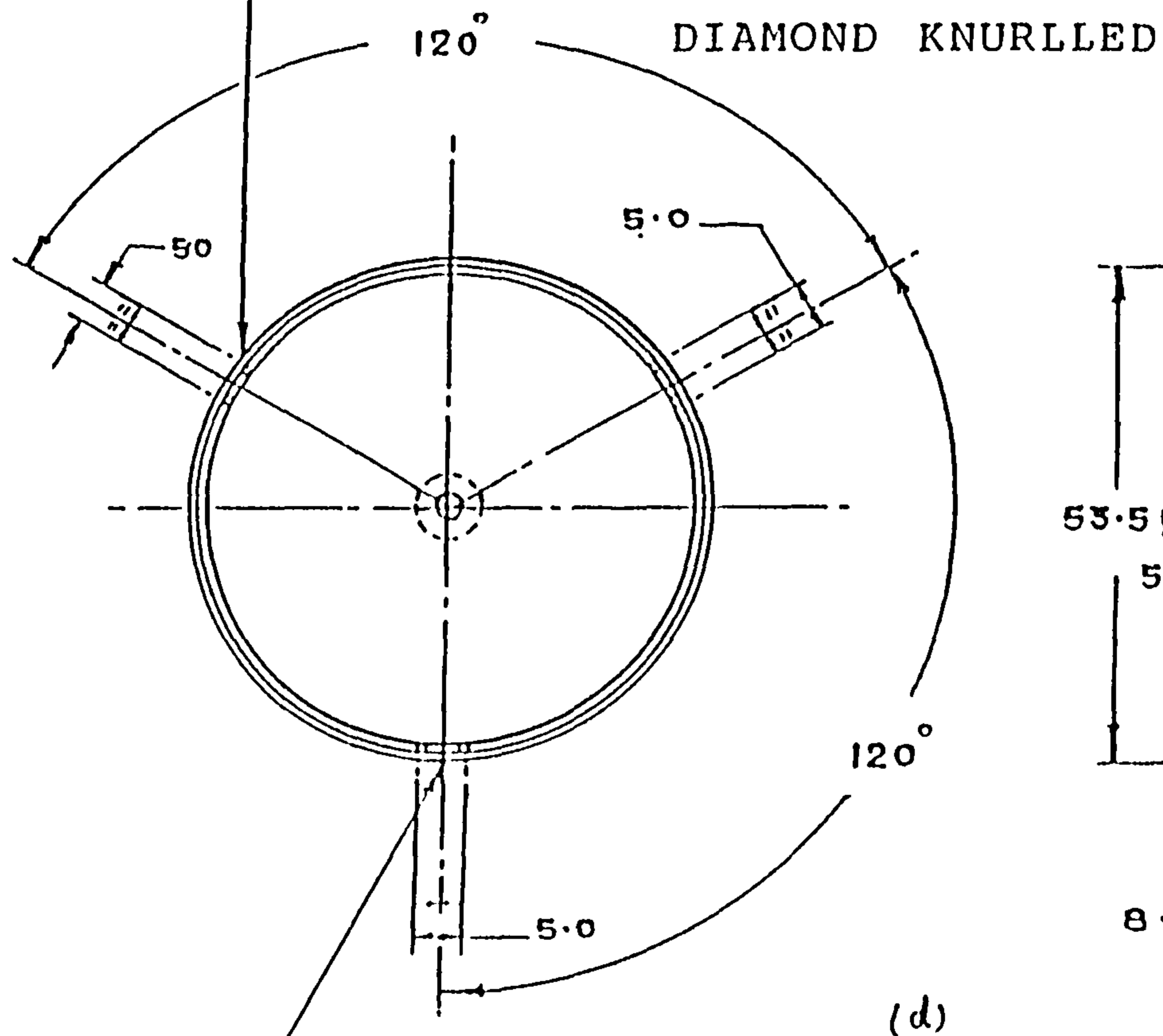

THESE PORTIONS SLIGHTLY PRESSED IN SIDE.

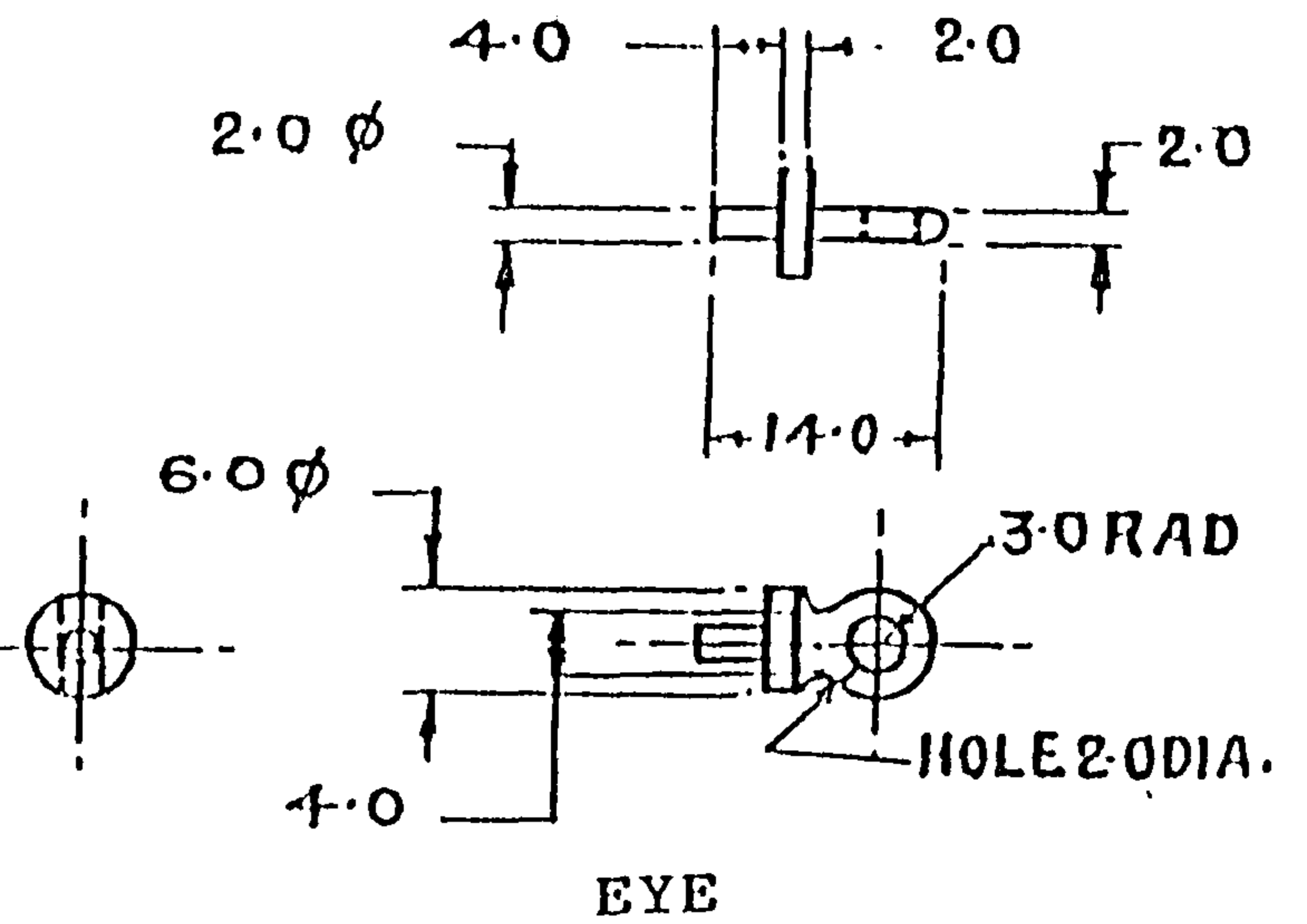

MATL:- BRASS IS:319
 FINISH:-CLEANED

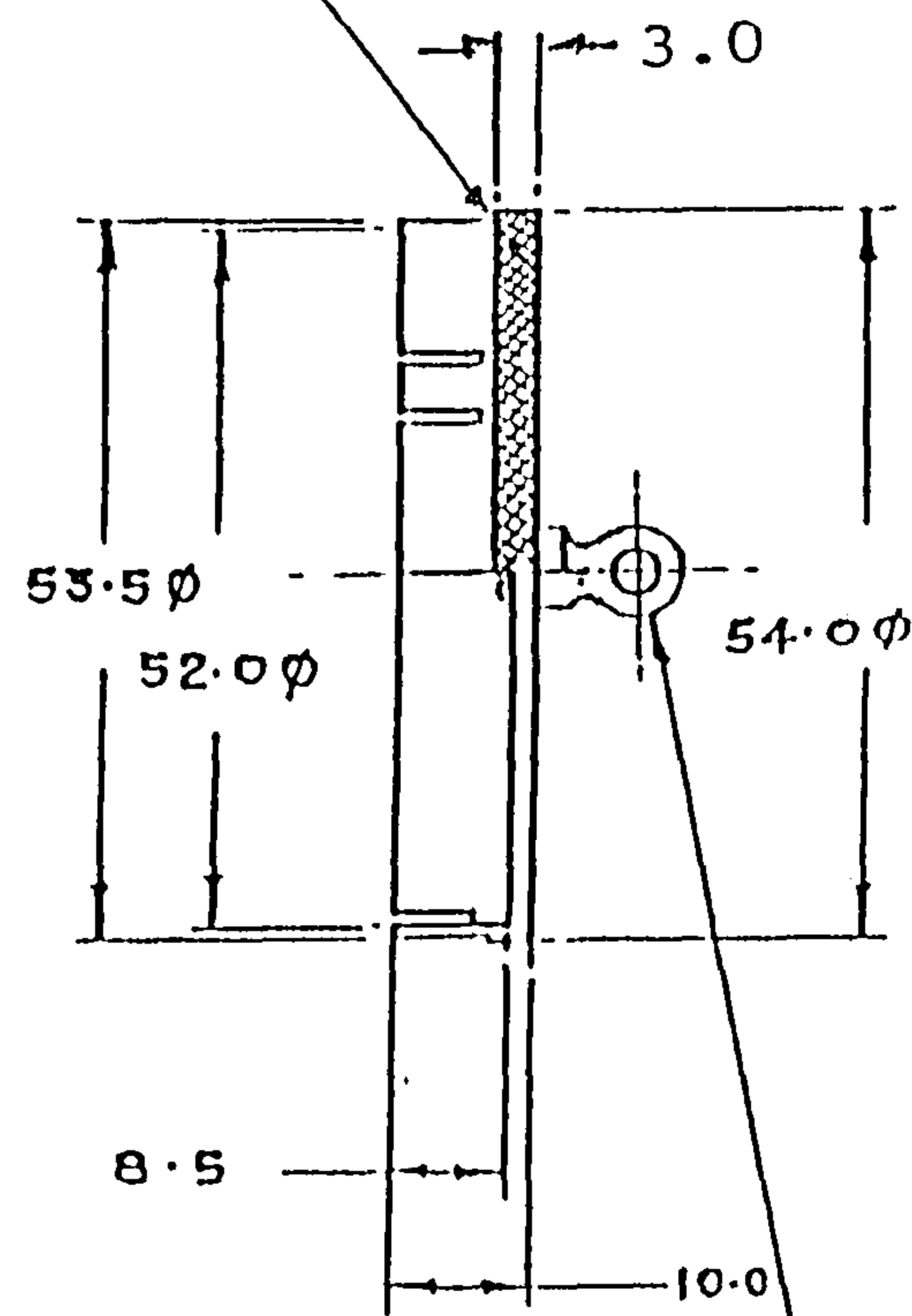

DETAILS TO BE RIVETED AS SHOWN IN POSITION AND PAINTED BLACK.

REDUCED DRG. PREPARED AT CQA(I) DEHRA DUN
 PREPARED BY : *Symul*
 CHECKED BY : *BS/Beoh.* DATE: 15.7.94

					DRN	Sd.	APPROVED Sd. FOR DIRECTOR IRDE DEHRADUN
					TCD	Sd.	
					CHD	Sd.	
					CHD		DATE:-30.6.72
	D.C:-5876-I. DRG. REDUCED & SEALED IN SUPERSESSION OF EXISTING ONE.			<i>W</i>	<i>R</i>	4.8.94.	USED
SYMB	AMENDMENTS			CHD	SIG	DATE	ON
MATL & SPEC	PHOSPHOR BRONZE Gd ₂ CuSn 4 OF IS:1385-1968						BASED ON
FINISH & SPEC	BRONZED BLACK 38MM MIN. THICKNESS TO IS:1378-1979.						CAI/PI No. 5340-002051
TITLE:- CAP, PROTECTIVE, DUST AND MOISTURE SEAL							DRG No. IRDE 1035/59
							SCALE : SH OF