

159 - 8L - 59L

▽3 Unless stated otherwise.

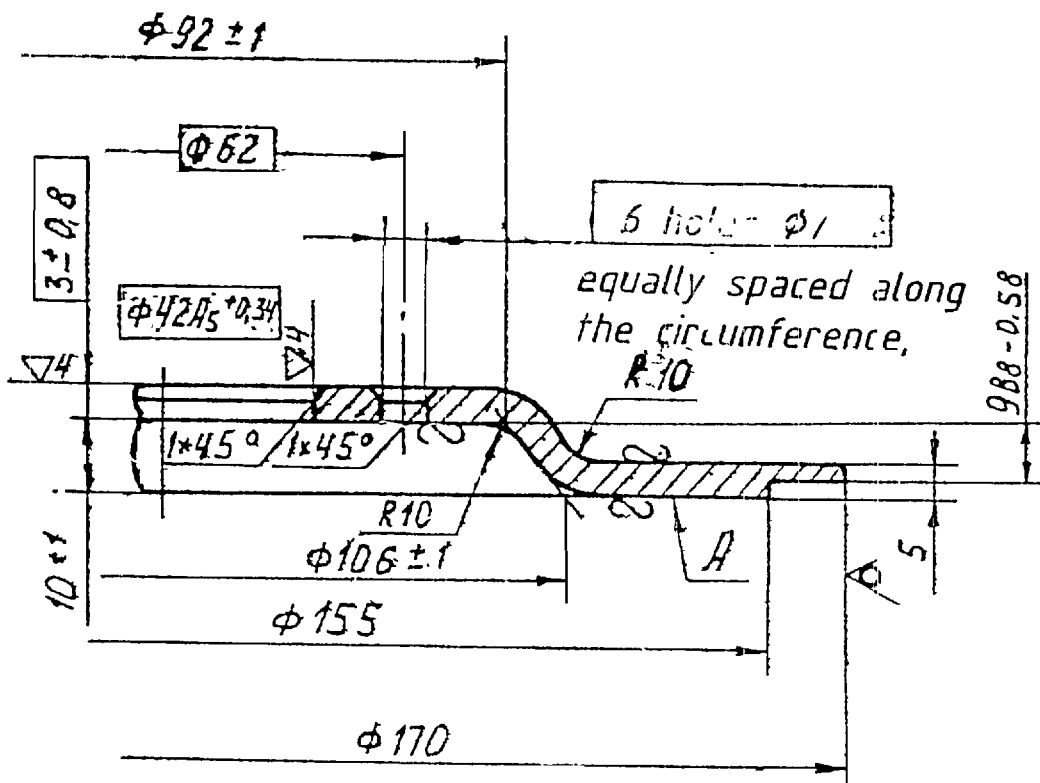

- 1) Blunt sharp edges
- 2) Perform dimensions without deviations as per Class 7, of accuracy, OCT 1010.
- 3) Displacement of axes of holes should not exceed 0.2 mm from their true position
- 4) Machine dimensions in  in assembly.
- 5) Non-flatness of surface: A may be 0,5 maximum
- 6) Alternate material is sheet AMF5 GOST 21631-76
7. Stamping draft not more than 0,5 mm is allowed,

MATERIAL :- SHEET AMF 65-5 GOST-21631-76		
ALL SHARP EDGES & CORNERS TO BE BOUNDED OFF	ALL THREADS TO CONFORM TO SPECIFICATION	STAMP OR ETCH, PART NO. MANUFACTURERS NAME & YEAR OF MFR.
DRG. NOT TO BE SCALED	TOLERANCE ON DIMENSIONS UNLESS OTHERWISE SPECIFIED	USED ON:-765-78-c8 383
SCALE :- 1:1	DATE :- 20-06-95	
DRN. <i>M. K. ...</i>	WT :- (Kg) 0,31	<b>FLANGE</b>
TCD. <i>M. K. ...</i>		
CHD. <i>...</i>		<b>765-78-691</b>
APD. <i>Bob</i>		
<b>CONTROLLERATE OF QUALITY ASSURANCE (INFANTRY COMBAT VEHICLES)</b>		

Имя, №, дата  
 20.06.95