

TRIPPLICATE
T-90S

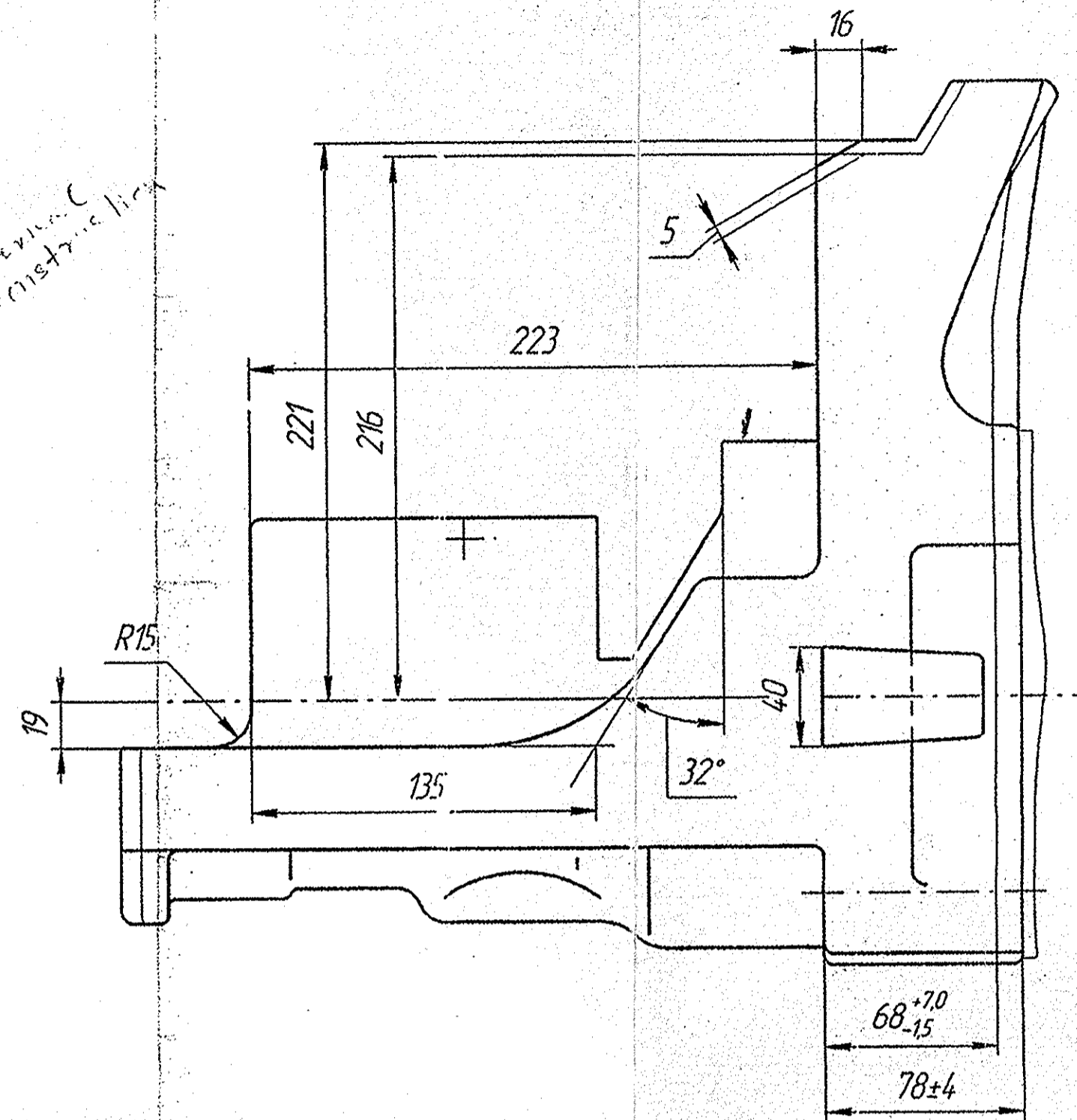

1. MATERIAL HEAT TREATMENT METHOD ACCEPTANCE TESTING AS PER LIST FOR COMPONENT FROM SPECIAL STEEL MEDIUM HARDNESS.
2. REQUIREMENT FOR CASTING IN COMPLIANCE WITH 172TY5 IN DIFFICULT TO REACH AREAS AND AREAS OF MATING PRESENCE OF BURN IS ALLOWED.
3. ACCURACY OF CASTING 1:1-0-0-9 GOST 26645-85.
4. EXTERNAL DRAFT ANGLES UP TO 1:50.
5. * DIMENSIONS FOR REFERENCE.
6. ALL THE INTERNAL AND EXTERNAL SURFACE SHOULD BE DRESSED FROM BURN ON STAND AND SCALES
7. OTHER REQUIREMENTS AS PER 520-TY1.
8. TO BE STAMPED STEEL GRADE HEAD NO.: SERIAL NO.: OF COMPONENT.
9. UNSPECIFIED CASTING RADII SHOULD NOT EXCEED 5MM
10. WEIGHT OF CASTING 73.6 KG.
11. SCALE 1:2.

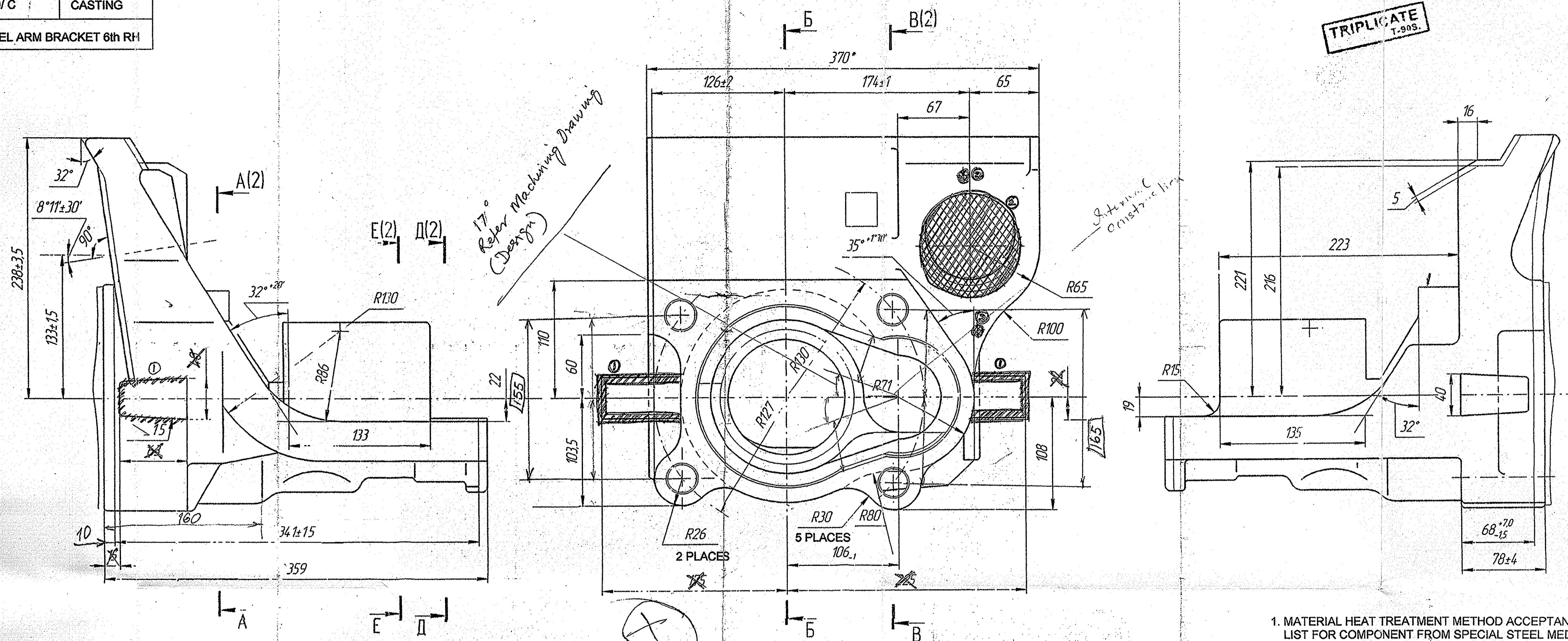
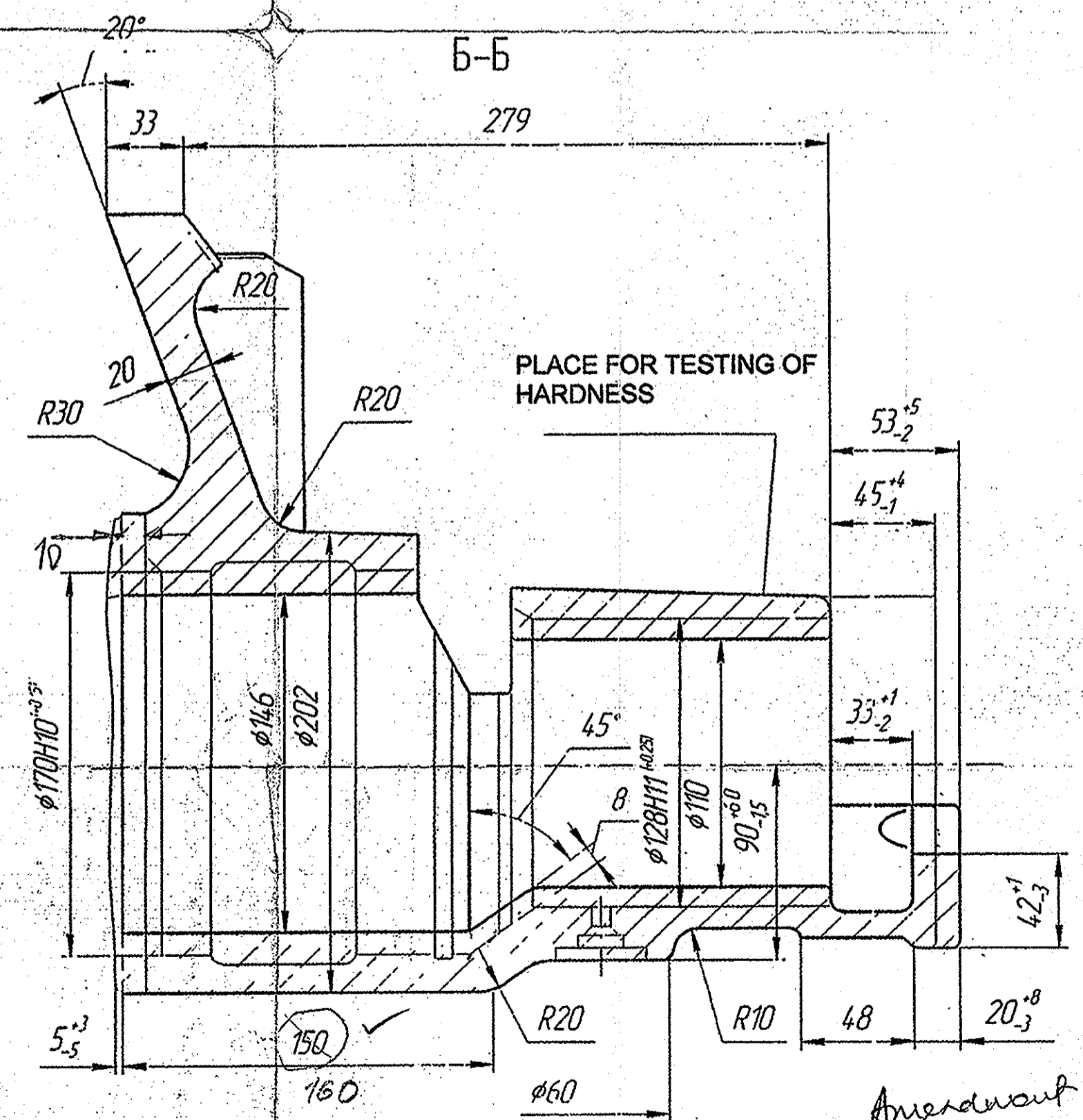
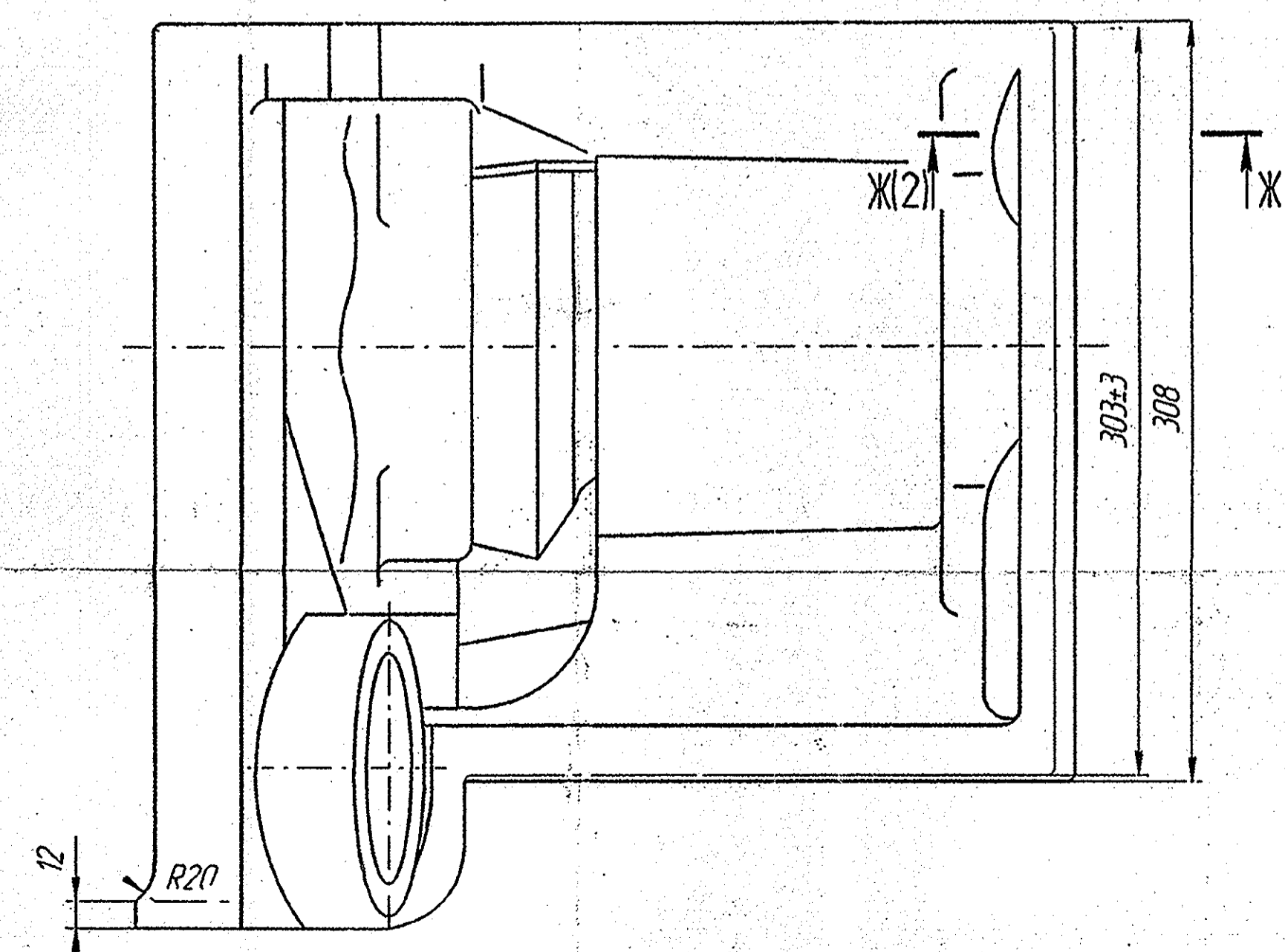

APPROVED
Divisional Officer (CA) 31/1/2002
केवल संदर्भ के लिए
FOR REFERENCE ONLY

Amendment to drawings
6/1/08

①	②	Notes to be blocked.
③	④	Ref: 13A amendment dt 1/6/05 by CA(IV) Tech Cell
⑤	⑥	Technological lugs removed.

T 90		
MATERIAL	CASTING WT.	
11-0-0-9 GOST 26645-85	73.6 KG	
ALT. MATERIAL	HAMMER	SCALE
		1:2
DRAWN	CHECKED	APPROVED
DRAWING NO. A172-01-729/C		
NOMENCLATURE: BRACKET		
HEAVY VEHICLES FACTORY		
AVADI, CHENNAI		