

NOTE:-  
WELDING AT JOINTS.

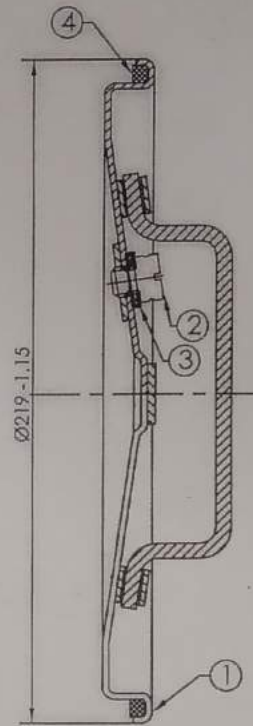
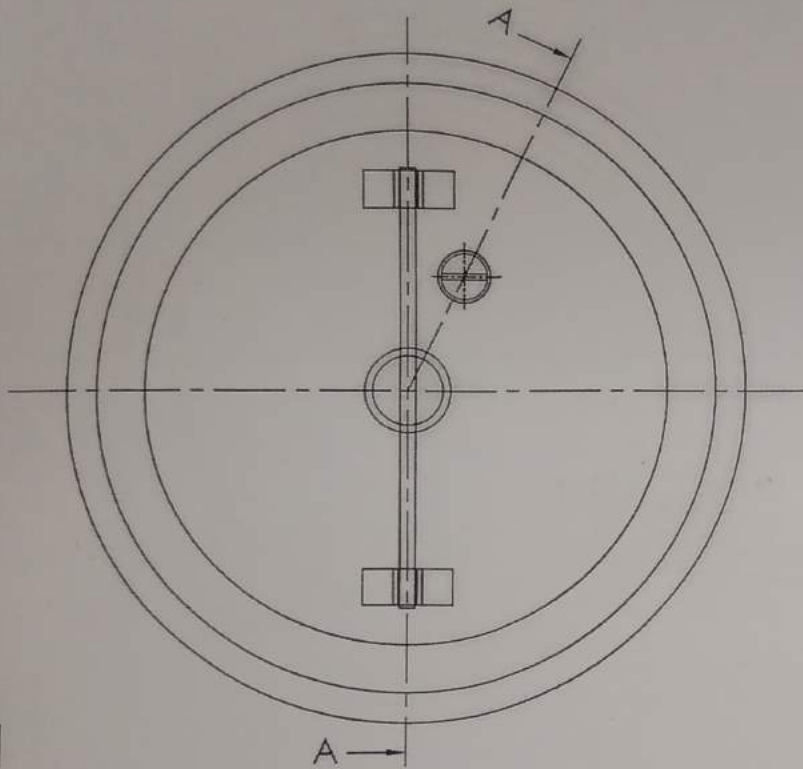

BILL OF MATERIAL			
Item No.	Description	OFBH Drg. No.	Qty
1	Cover Sub assembly-II	OFBH/SK/1551	1
2	Screw	OFBH/SK/1552	1
3	Gasket	OFBH/SK/1553	1
4	Rubber Ring	OFBH/SK/1554	1

NOTE:-  
Samples should got approved before bulk supply.  
Drawing is for reference.

NOTE:-  
Rubber Ring (Item No.4) should not be glued with Cover sub assembly-II (Item No.1). It should be provided in loose (without fitting).

SECTION 'A-A'

TITLE :- <b>LID SUB ASSEMBLY</b> for Metallic Container for OF Bhandara		2021	NAME	SIGN	DATE
NOTE :- 1) ALL DIMENSIONS ARE IN MM. 2) UNSPECIFIED TOLERANCES AS PER IS 2102 (MED).		JWM/SHOP	N. PRAKASH	<i>[Signature]</i>	27
SCALE :- NTS		DGN./DRN.	R.R.SAHARE	<i>[Signature]</i>	27/3
ORDNANCE FACTORY BHUSAWAL		JWM/CHD	N.TADVI	<i>[Signature]</i>	4/3
		HOS/DO	V.KANDWAL	<i>[Signature]</i>	27/3
		DIV.O/DO	AKASH VERMA	<i>[Signature]</i>	27/3
ID NO:- Drg4/ Metallic container		DRG.NO:- OFBH/SK/1533			

THIS DRAWING IS THE PROPERTY OF OF BHUSAWAL MINISTRY OF DEFENCE, GOVT OF INDIA. IT SHOULD NOT BE COPIED / REPRODUCED IN ANY WAY.

R.NO.	DATE	AUTHORITY	REVISION	SIGN.

NOTE:-  
WELDING AT JOINTS.

BILL OF MATERIAL			
Item No.	Description	OFBH Drg. No.	Qty
1	Neck Cover	OFBH/SK/1546	1
2	Thrust member	OFBH/SK/1547	1
3	Washer	OFBH/SK/1548	1

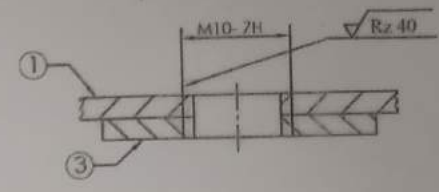
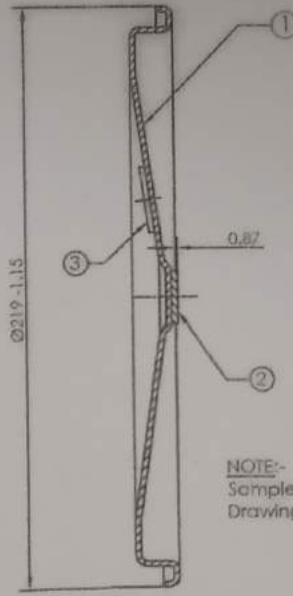
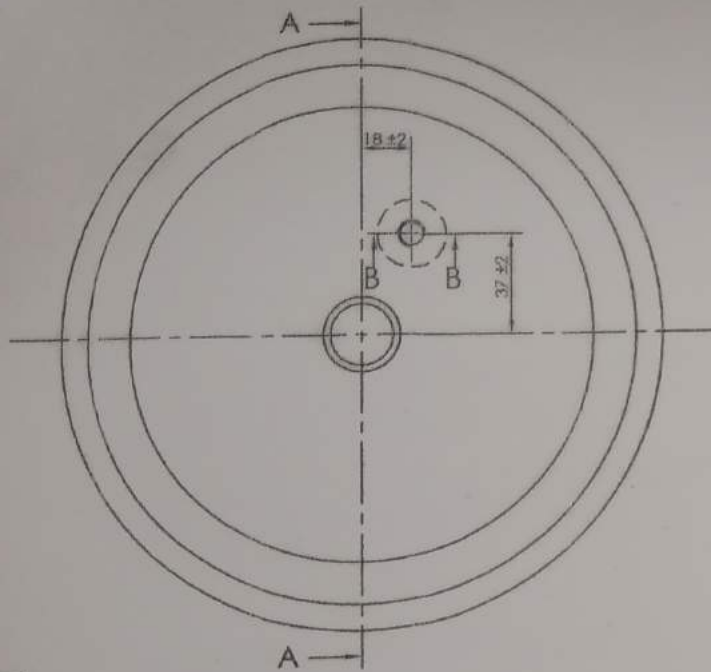

SECTION 'B-B' (enlarge view)

NOTE:-  
Samples should get approved before bulk supply.  
Drawing is for reference.

SECTION 'A-A'

THIS DRAWING IS THE PROPERTY OF O.F BHUSAWAL. IT SHOULD NOT BE COPIED / REPRODUCED IN ANY WAY.

TITLE :- <b>COVER SUB ASSEMBLY-I</b> for Metallic Container for OF Bhandara	2021	NAME	SIGN	DATE
NOTE :- 1) ALL DIMENSIONS ARE IN MM. 2) UN-SPECIFIED TOLERANCES AS PER IS 2102 (MED).	JWM/SHOP	N. PRAKASH	<i>[Signature]</i>	<i>[Date]</i>
	DGN./DRN.	R.R.SAHARE	<i>[Signature]</i>	<i>[Date]</i>
	JWM/CHD	N.TADVI	<i>[Signature]</i>	<i>[Date]</i>
	HOS./DO	V.KANDWAL	<i>[Signature]</i>	<i>[Date]</i>
	DIV.O/DO	AKASH VERMA	<i>[Signature]</i>	<i>[Date]</i>

SCALE :- NTS	ORDNANCE FACTORY BHUSAWAL	ID NO:- Drg/ Metallic container
		DRG.NO:- OFBH/SK/1545

REV. NO.	DATE	AUTHORITY	REVISION	SIGN.
1				
2				
3				
4				

NOTE-

NOTE

ENSURE SURFACE FINISH  $\nabla 3$   
UNLESS OTHERWISE SPECIFIED.

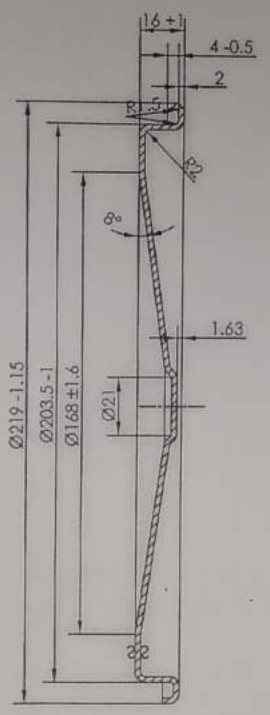
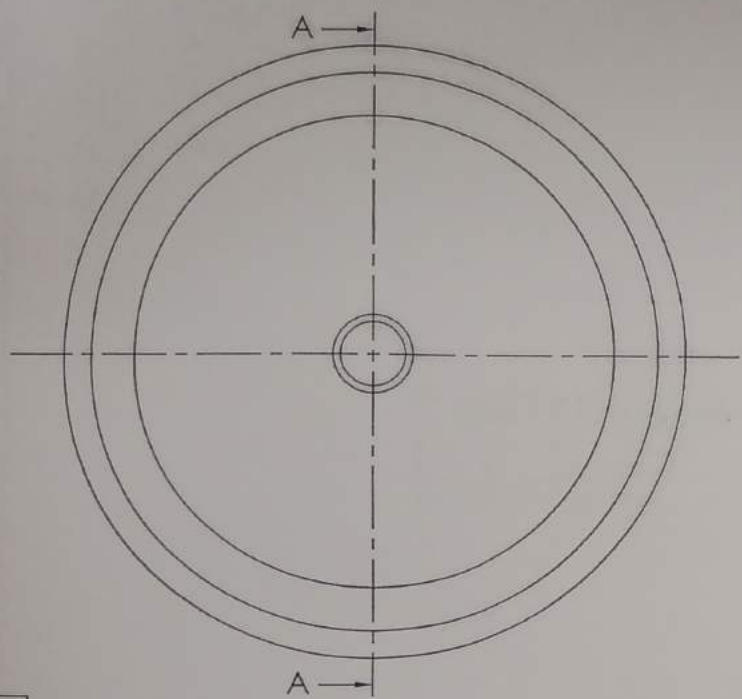

SECTION 'A-A'

MATERIAL:-  
SHEET TO SPEC. IS:1079:1994, Grade DD.

NOTE:-  
Samples should got approved before bulk supply.  
Drawing is for reference.

THIS DRAWING IS THE PROPERTY OF OF Bhusawal  
MINISTRY OF DEFENCE, GOVT. OF INDIA. IT SHOULD NOT  
BE COPIED / REPRODUCED IN ANY WAY.

TITLE :-				2021	NAME	SIGN	DATE
NECK COVER for Metallic Container for OF Bhandara				JWM/SHOP	N. PRAKASH	<i>[Signature]</i>	27/3
				DGN./DRN.	R.R.SAHARE	<i>[Signature]</i>	27/3
NOTE > 1) ALL DIMENSIONS ARE IN MM. 2) UNSPECIFIED TOLERANCES AS PER IS 2102 (MED).				JWM/CHD	N.TADVI	<i>[Signature]</i>	27/3
				HOS/DO	V.KANDWAL	<i>[Signature]</i>	27/3
				DIV.O/DO	AKASH VERMA	<i>[Signature]</i>	29/3
SCALE :- NTS				ORDNANCE FACTORY BHUSAWAL			
R.NO.				ID NO:- Drg4/ Metallic container			
DATE				DRG. NO.:- OFBH/SK/1546			
AUTHORITY							
REVISION							
SIGN.							

SIGN	DATE
<i>[Signature]</i>	27/3
<i>[Signature]</i>	27/3
<i>[Signature]</i>	27/3
<i>[Signature]</i>	27/3

Cover  
In loose

TERIAL  
OFBH Drg. N  
H/SK/1551  
/SK/1552  
/SK/1553  
SK/1554

33

PROVIDE SURFACE FINISH  $\nabla 2$   
UNLESS OTHERWISE SPECIFIED.

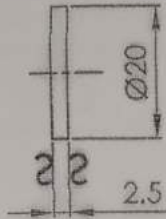

MATERIAL:-  
SHEET TO SPEC. IS:1079:1988, GR.St.34.

NOTE:-  
Samples should got approved before bulk supply. Drawing is for reference.

THIS DRAWING IS THE PROPERTY OF O.F. BHUSAVAL  
MINISTRY OF DEFENCE, GOVT. OF INDIA. IT SHOULD NOT  
BE COPIED / REPRODUCED IN ANY WAY.

ITEM	DESCRIPTION	QTY.	MATL.	TREATMENT	REMARKS
<u>TITLE:-</u> <b>THRUST MEMBER</b>		2021	NAME	SIGN	DATE
for Metallic Container for OF Bhandara		HOS/SHOP	N. PRAKASH	<i>[Signature]</i>	22/3
		DGN./DRN.	R.R.SAHARE	<i>[Signature]</i>	22/3
		JWM/CHD.	N.TADVI	<i>[Signature]</i>	22/3
		HOS/DO	V.KANDWAL	<i>[Signature]</i>	22/3
		DIV.O/DO	A.VERMA	<i>[Signature]</i>	22/3
NOTE :- 1) ALL DIMENSIONS ARE IN MM. 2) UNSPECIFIED TOLERANCES AS PER IS 2102 (MED).					
SCALE :- NTS	<b>ORDNANCE FACTORY BHUSAVAL</b>	ID NO. DRG_4/ Metallic container			
		DRG NO: <b>OFBH/SK/1547</b>			

✓ (✓)

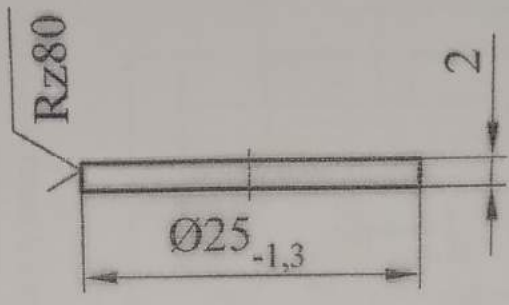

**MATERIAL:-**  
IS 513:2008 Grade CR1 Grade 440.

**NOTE:-**  
Samples should got approved before bulk supply.  
Drawing is for reference.

ITEM	DESCRIPTION	QTY.	MATL.	TREATMENT	REMARKS
<b>TITLE:- WASHER</b>		2021	NAME	SIGN	DATE
<u>for Metallic Container for OF Bhandara</u>		HOS/SHOP	N. PRAKASH	<i>[Signature]</i>	27/3
		DGN./DRN.	R.R.SAHARE	<i>[Signature]</i>	27/3
		JWM/CHD.	N.TADVI	<i>[Signature]</i>	27/3
		HOS/DO	V.KANDWAL	<i>[Signature]</i>	27/3
		DIV.O/DO	A.VERMA	<i>[Signature]</i>	27/3
NOTE :- 1) ALL DIMENSIONS ARE IN MM. 2) UNSPECIFIED TOLERANCES AS PER IS 2102 (MED).		ID NO. DRG_A/ Metallic container			
SCALE :- NTS	<b>ORDNANCE FACTORY BHUSAWAL</b>	DRG NO: <b>OFBH/SK/1548</b>			

THIS DRAWING IS THE PROPERTY OF OF BHUSAWAL  
MINISTRY OF DEFENCE, GOVT. OF INDIA, IT SHOULD NOT  
BE COPIED / REPRODUCED IN ANY WAY.

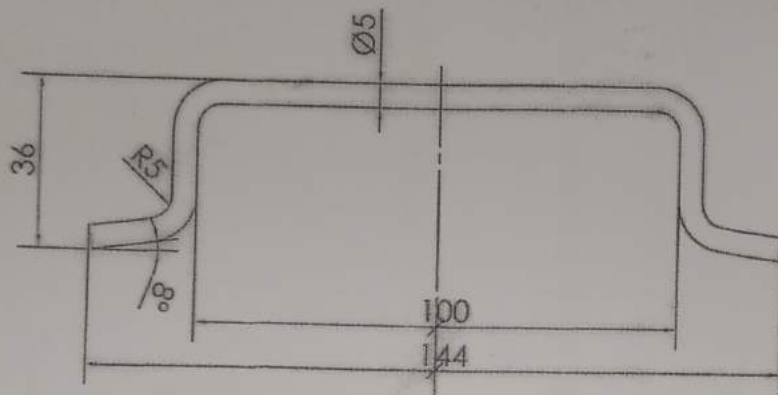

MATERIAL :-  
 BAR STEEL TO SPEC. IS:2062:1992 Gr. Fe 410WB.

NOTE:-  
 Samples should got approved before bulk supply.  
 Drawing is for reference.

MINISTRY OF DEFENCE, GOVT OF INDIA. IT SHOULD NOT BE COPIED / REPRODUCED IN ANY WAY.

TITLE :-		2021	NAME	SIGN	DATE
COVER HANDLE for Metallic Container for OF Bhandara		JWM/SHOP	N. PRAKASH	<i>[Signature]</i>	27/3
		DGN/DRN	R.R.SAHARE	<i>[Signature]</i>	27/3
NOTE :- 1) ALL DIMENSIONS ARE IN MM. 2) UNSPECIFIED TOLERANCES AS PER IS 2102 (MED).		JWM/CHD	N.TADVI	<i>[Signature]</i>	01/0
		HOS/DO	V.KANDWAL	<i>[Signature]</i>	29/3
		DIV.O/DO	ANASH VERMA	<i>[Signature]</i>	29/3
SCALE:- NTS		ORDNANCE FACTORY BHUSAWAL		ID NO:- Drg4/ Metallic container	
				DRG.NO:- OFBH/SK/1549	

R.NO.	DATE	AUTHORITY	REVISION	SIGN.
1				
2				
3				
4				

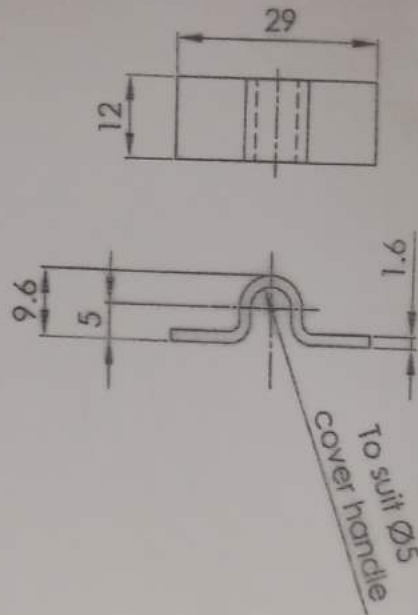

**MATERIAL:-**

M.S. CONFORMING TO IS 513-1996 COLD ROLLED & ANNEALED TYPE'D' BEST SURFACE.

**NOTE:-**

Samples should got approved before bulk supply. Drawing is for reference.

ITEM	DESCRIPTION	QTY.	MATL.	TREATMENT	REMARKS
<b>TITLE:-</b> <b>COVER HANDLE CLIP</b> <b>for Metallic Container for OF Bhandara</b>		2021	NAME	SIGN	DATE
		HOS/SHOP	N. PRAKASH	<i>[Signature]</i>	2/13
		DGN./DRN.	R.R.SAHARE	<i>[Signature]</i>	2/13
		JWM/CHD.	N.IADVI	<i>[Signature]</i>	2/13
NOTE :- 1) ALL DIMENSIONS ARE IN MM. 2) UNSPECIFIED TOLERANCES AS PER IS 2102 (MED).		HOS/DO	V.KANDWAL	<i>[Signature]</i>	2/13
		DIV.O/DO	A.VERMA	<i>[Signature]</i>	2/13
SCALE :- NTS	<b>ORDNANCE FACTORY</b> <b>BHUSAWAL</b>	ID NO. DRG_4/ Metallic container			
		DRG NO: <b>OFBH/SK/1550</b>			

THIS DRAWING IS THE PROPERTY OF OF BHUSAWAL  
 MINISTRY OF DEFENCE, GOVT. OF INDIA. IT SHOULD NOT  
 BE COPIED / REPRODUCED IN ANY WAY.

NOTE:-  
WELDING AT JOINTS.

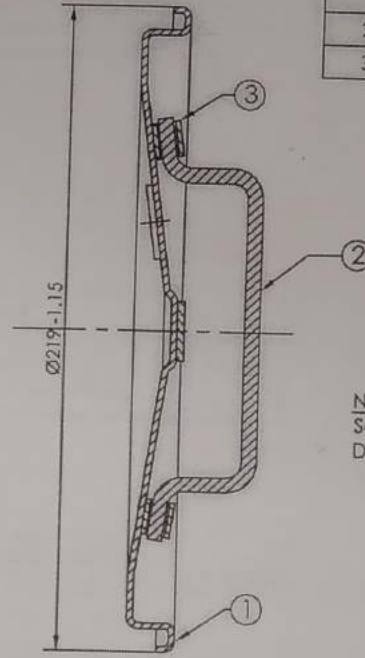
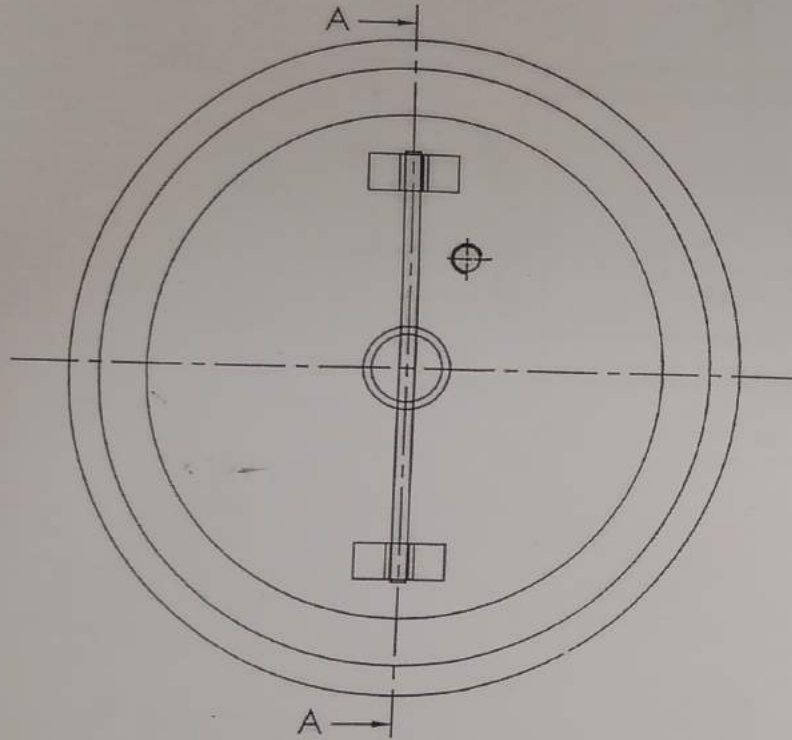

SECTION 'A-A'

BILL OF MATERIAL			
Item No.	Discription	OFBH Drg. No.	Qty
1	Cover Sub assembly-I	OFBH/SK/1545	1
2	Cover handle	OFBH/SK/1549	1
3	Cover handle clip	OFBH/SK/1550	1

NOTE:-  
Samples should got approved before bulk supply.  
Drawing is for reference.

BE COPIED / REPRODUCED IN ANY WAY.

TITLE :-

**COVER SUB ASSEMBLY-II**  
for Metallic Container for OF Bhandara

NOTE :- 1) ALL DIMENSIONS ARE IN MM.  
2) UNSPECIFIED TOLERANCES AS PER IS 2102 (MED).

SCALE :- NTS

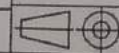

**ORDNANCE FACTORY**  
**BHUSAWAL**

2021	NAME	SIGN	DATE
JWM/SHOP	N. PRAKASH	<i>[Signature]</i>	<i>[Date]</i>
DGN./DRN.	R.R.SAHARE	<i>[Signature]</i>	<i>[Date]</i>
JWM/CHD	N.TADVI	<i>[Signature]</i>	<i>[Date]</i>
HOS/DO	V.KANDWAL	<i>[Signature]</i>	<i>[Date]</i>
DIV.O/DO	AKASH VERMA	<i>[Signature]</i>	<i>[Date]</i>

ID NO:- Drg4/ Metallic container

DRG. NO:- OFBH/SK/1551

R.NO.	DATE	AUTHORITY	REVISION	SIGN.
1				
2				
3				
4				



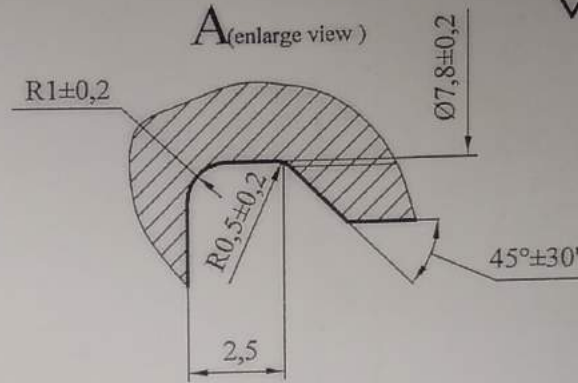
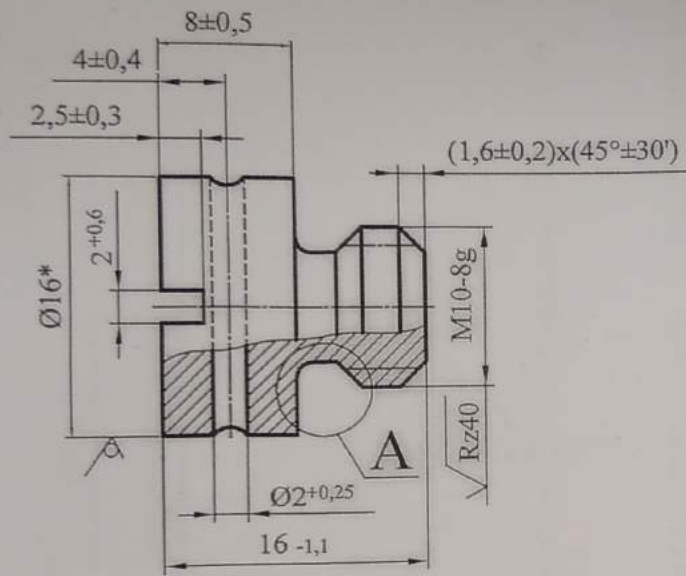

√ Rz80 (√)

**Material:** IS:319-2007 Grade 2, Condition 'Hard' subject to achieve %EI 11% min as per OEM alongwith other properties.  
 Alternately, IS:319-2007 Grade 1, Condition 'Hard'.

**NOTE:-**  
 Samples should got approved before bulk supply. Drawing is for reference.

THIS DRAWING IS THE PROPERTY OF O.F. BHUSAWAL  
 MINISTRY OF DEFENCE, GOVT. OF INDIA, IT SHOULD NOT  
 BE COPIED / REPRODUCED IN ANY WAY.

TITLE :- <b>SCREW</b>				2021	NAME	SIGN	DATE
for Metallic Container for OF Bhandara				JWM/SHOP	N.PRAKASH	[Signature]	27/3
NOTE :- 1) ALL DIMENSIONS ARE IN MM. 2) UNSPECIFIED TOLERANCES AS PER IS 2102 (MED).				DRG./DRN.	R.R.SAHARE	[Signature]	27/3
				JWM/CHD.	N.TADVI	[Signature]	27/3
				JWM/HOS/DO	V. KANDWAL	[Signature]	27/3
				AWM/AV	A.VERMA	[Signature]	27/3
				ID NO: DRG_4/Metallic container			
				DRG. NO: OFBH/SK/1552			

R.NO.	DATE	AUTHORITY	REVISION	SIGN.	SCALE: NTS	5	6	7	8
1									
DRG. SEALED :-									

SCALE: NTS  
 आभय निर्माणी समल  
 ORDNANCE FACTORY BHUSAWAL

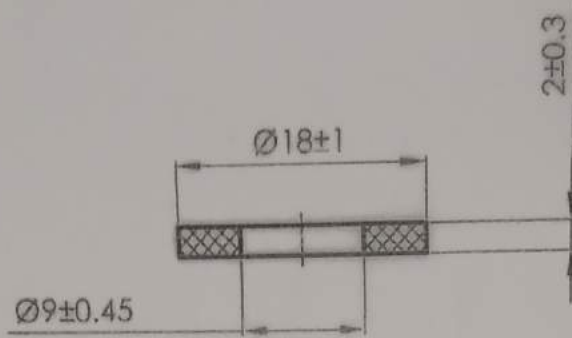

**MATERIAL:-**

Vulcanised Chloroprene Rubber Compounds (Neoprene) Grade C-60 to Specification IND/E/884:2015.

**NOTE:-**

Samples should get approved before bulk supply. Drawing is for reference.

ITEM	DESCRIPTION	QTY.	MATL.	TREATMENT	REMARKS
<b>TITLE:-</b> <b>GASKET</b> for Metallic Container for OF Bhandara		2021	NAME	SIGN	DATE
		HOS./SHOP	N. PRAKASH	<i>[Signature]</i>	27/3
		DGN./DRN.	R.R.SAHARE	<i>[Signature]</i>	27/3
		JWM/CHD.	N.TADVI	<i>[Signature]</i>	27/3
		HOS./DO	V.KANDWAL	<i>[Signature]</i>	27/3
		DIV.O/DO	A.VERMA	<i>[Signature]</i>	27/3
NOTE :- 1) ALL DIMENSIONS ARE IN MM. 2) UNSPECIFIED TOLERANCES AS PER IS 2102 (MED).		ID NO. DRG_4/ Metallic container			
SCALE :- NTS 		<b>ORDNANCE FACTORY</b> <b>BHUSAWAL</b> DRG NO: OFBH/SK/1553			

THIS DRAWING IS THE PROPERTY OF OF BHUSAWAL  
 MINISTRY OF DEFENCE, GOVT OF INDIA, IT SHOULD NOT  
 BE COPIED / REPRODUCED IN ANY WAY.

AUTHORITY

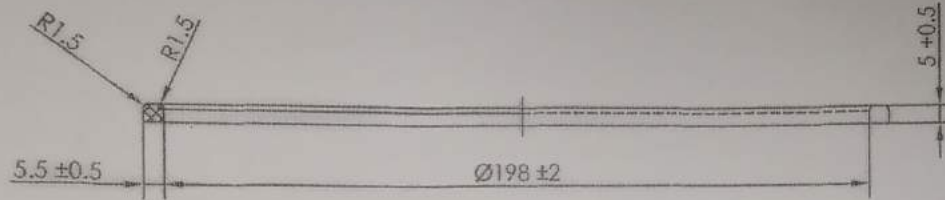

**MATERIAL:-**

Vulcanized Chloroprene Rubber Compounds (Neoprene) Grade C-40 to Spec. IND/ME/884:2015.

**NOTE:-**

Samples should got approved before bulk supply. Drawing is for reference.

THIS DRAWING IS THE PROPERTY OF O.F. BHUSAWAL MINISTRY OF DEFENCE, GOVT. OF INDIA, IT SHOULD NOT BE COPIED / REPRODUCED IN ANY WAY.

TITLE :-		2021	NAME	SIGN	DATE
RUBBER RING			N. PRAKASH	[Signature]	13
for Metallic Container for OF Bhandara			R.R.SAHARE	[Signature]	27/3
NOTE :- 1) ALL DIMENSIONS ARE IN MM. 2) UNSPECIFIED TOLERANCES AS PER IS 2102 (MED).			N.TADVI	[Signature]	27/3
			V. KANDIAL	[Signature]	27/3
			AKASH VERMA	[Signature]	27/3
SCALE:- NTS		ORDNANCE FACTORY BHUSAWAL		ID NO:- Drg/ Metallic container	
				Dwg. NO:- OFBH/SK/1554	

R.NO.	DATE	AUTHORITY	REVISION	SIGN.
1				
2				
3				
4				

with Cover supply.

OF MAAT OF OFBH/SK OFBH/SK OFBH/SK