

DRG. NO. SK-6513/TE

D.A. NO.

Hos / mMD

20.7.23

$\sqrt{Rz 20}$ (✓)

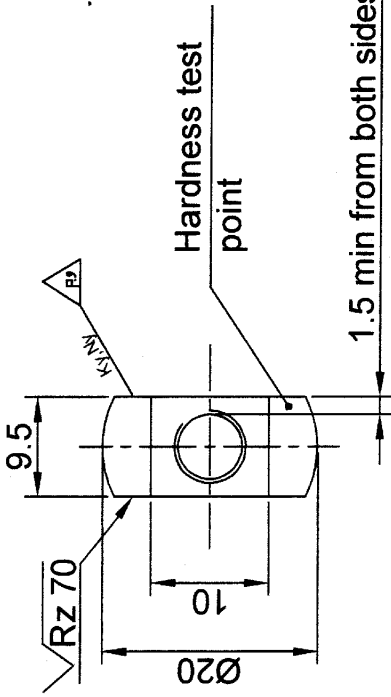

1.5 min from both sides

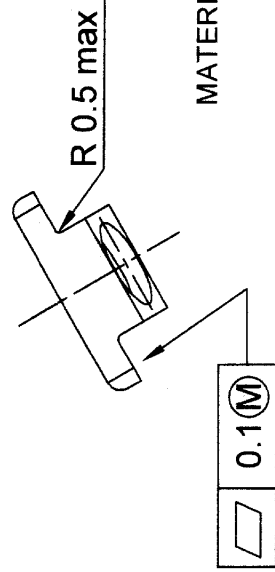
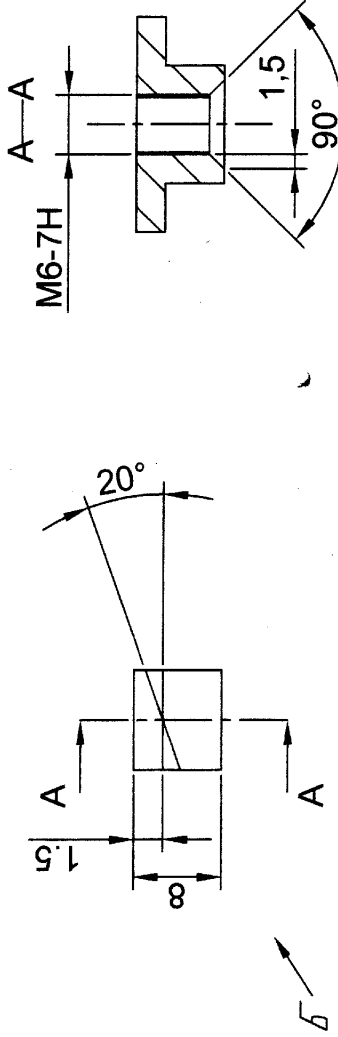

1. Unspecified cost rounding radii of inner and outer angles from R0.5 to R1 mm.
2. Position, size and quantity of cost defects should not exceed those specified by control sample.
3. Pattern draft angles not greater than 1° increasing.
4. Traces from ejectors up to minus 0.3 mm.
5. Outline displacement at point of mold split is not greater than 0.2 mm.
6. 38...45 HRC At hardness test point local smoothing of surface is allowed at depth up to 0.2 mm.
7. Unspecified tolerance according to 11 45 - 1C8 TY/E2
8. Coating is Chem. Phos. chr/impreg with δ 4 glue GOST 12172-2016 with nigrosine grade A GOST 9307-78.
9. Stamp.

DRAWN		SEEN BY	CHECKED
DATE		06-06-2023	
APPROVED			
7.62X39mm AR-SAF			
NUT			
SCALE	SMALL ARMS FACTORY		
NTS	KANPUR		
DRG. NO.			SK-6513/TE
SHT.			1 OF 1

MATERIAL:- CASTING 116Л45 - 1C8TY/E2
50ЛК30 GOST 977-88