

SECTION C-C

TEST/CHECKS & ACCEPTANCE CRITERIA FOR RAW MATL.:  
NABL TEST CERTIFICATES TO BE SUBMITTED BY THE  
MANUFACTURE AS PER SPECIFICATION OR ORIGINAL  
MANUFACTURES CERTIFICATE.

PHOSPHATING TO SPECN IS: 3618-1996, TO CLASS A2.

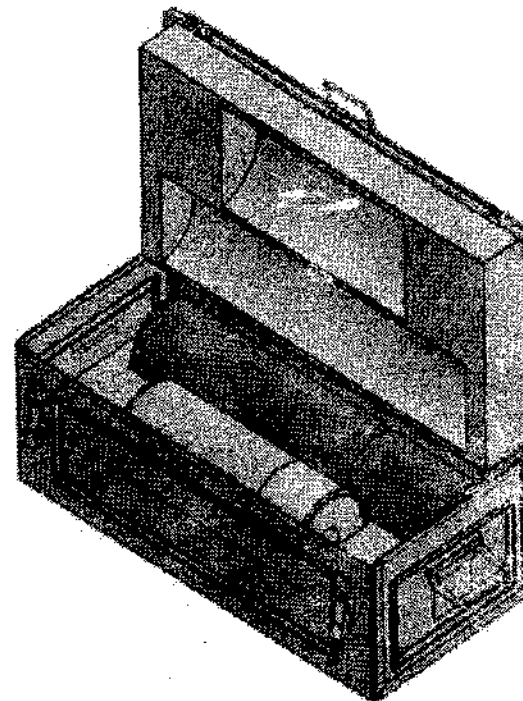

PROVISIONAL

NOTES :-

a) EACH CATCH ( I.A.793:SHT-3) SECURED TO BODY BY 3 SPOT WELD Ø5.

b) EACH HANDLE CLIP SECURED TO END BY A RIVETS HOLES IN THE END TO SUIT THE A ABOVE RIVETS ALTERNATIVELY EACH HANDLE CLIP MAY BE SECURED BY 3 SPOT WELDS Ø5 AND ARC WELDED AT THE CORNERS AND THE CENTER OF THE PLATE.

c) EACH PLATE HOOK SECURED TO LID BY 2 SPOT WELDED Ø5 OR MAY BE SECURED BY 2 RIVETS Ø5.

d) EACH HINGE SECURED TO BODY AND LID 4 RIVETS HOLES IN BODY AND LID TO SUIT Ø5 RIVETS ALTERNATIVELY EACH MAY BE SECURED TO BODY AND LID BY 4 SPOT WELDS Ø5 .

e) THE BRACKET TOP TO BE SECURED IN LID, BRACKET MIDDLE, REAR, CROSS, SIDE, AND SUPPORT TO BE ARE SECURED TO BODY BY 4 TO 6 SPOT WELDS Ø5 EACH & ARC WELDED ALL OVER.  
ALL WELDING JOINTS AS PER SEC. IS : 813  
TECHNICAL REQUIREMENTS AS PER SPEC. No. IA 1169 (LATER ISSUE).

f) ON COMPLETION OF THE EMPTY BOX BEFORE DELIVERY THE CATCH LOCKING MUST BE SECURE WITH A PIECE OF WIRE SOFT IRON Ø0.5 TO Ø1.0 TO SPEC. IS:280-1978 TO PREVENT DAMAGE OF THE CATCH LOCKING DURING TRANSIT.

g) FLANGE OF THE LID TO BE CUT IN SUCH A MANNER SO AS TO PROVIDE OVERLAP AT EACH OF THE CORNER, RIVETS SHOULD BE M.S. FLAT HEAD TO SPEC. IS:2996-1982, TIN PLATED AS PER SPEC. IS:1359 Sn:205.

LIFTING BAND TO BE SECURED TO BODY WITH STRENGTHENING PLATE M.S. 25 X 15 X 2 THICK (COMMERCIAL VARIET) BY TWO REVETS Ø3 X 8 LONG -QTY. 8

MARKING TO BE EMBOSSED ON LID AT PLAIN SURFACE IN 13 mm TYPE.

\*YEAR OF MANUFACTURE

† MANUFACTURE'S INITIALS OR RECOGNIZED TRADE MARK.

PROVISIONAL

ITEM NO		MATERIAL AS STATED		NO.OFF	NOMENCLATURE	REMARKS
2		COLD ROLLED LOW CARBON STEEL SHEETS & STRIP		1	STEEL BOX ASSEMBLY	
1		COLD ROLLED LOW CARBON STEEL SHEETS & STRIP		1	TOP CONTAINER ASSY.	
MASS:-				आयुध निर्माणी, चांदा DISTANCE FACTORY CHANDA		
				STEEL PACKAGE FOR ROUND 125MM HE		
PREPD.BY		SIGN	DATE	05.10.23		
OIC/R&D		DATE	13/10	ASSLY.& STORE DRG. NO.- PACKING BOX FOR ROUND 125MM HE		
DO/R&D		DATE	14/10	DRG. NO.:-PROP/SK-845-01		
D.A.NO	DATE	DETAILS	IP/TL	DATE	05.10.23	
REVISIONS				SCALE	1:2	

PROVISIONAL

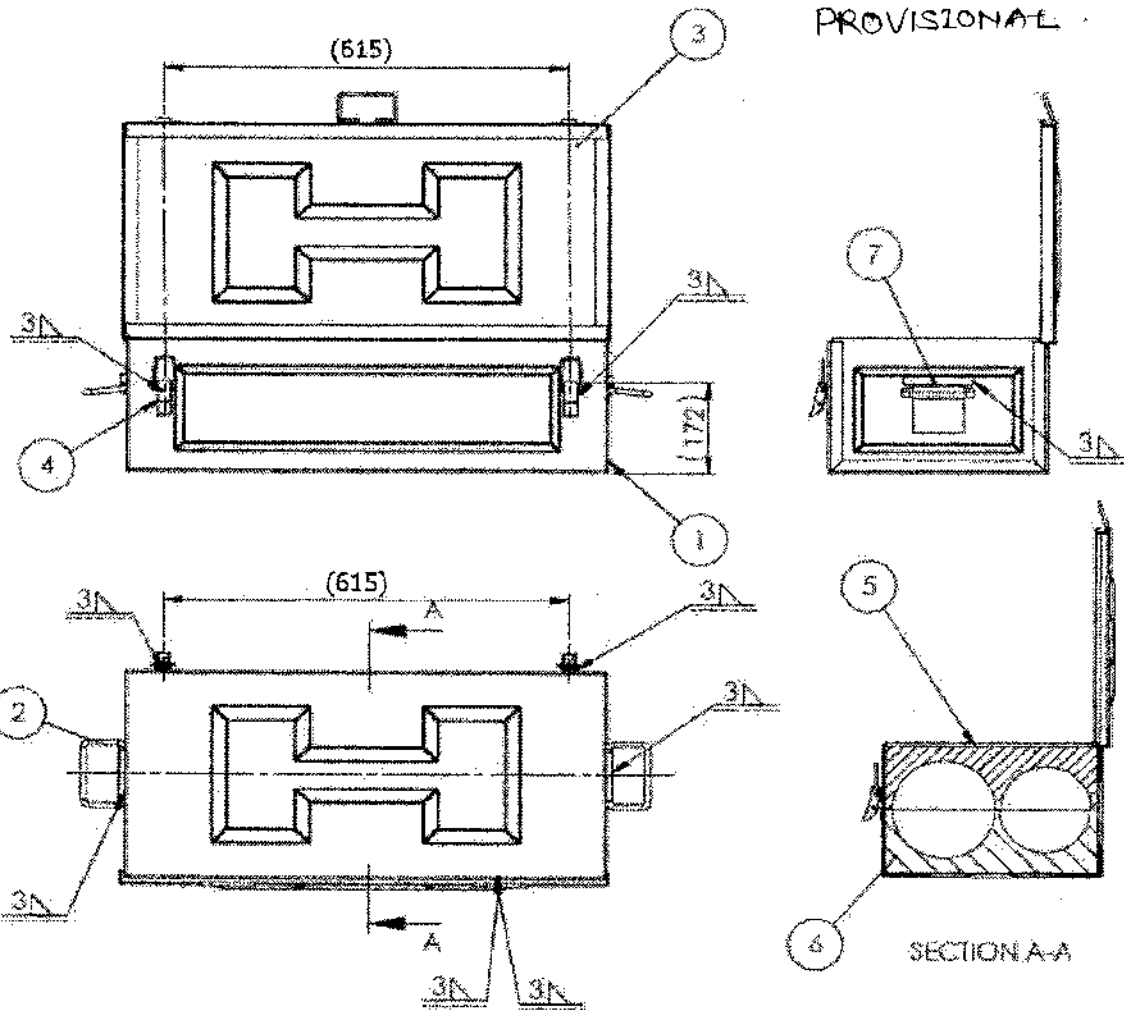

**PAINTING & PROTECTIVE TREATMENT: -**  
 AFTER CLEANING & INSPECTION THE BOX INCLUDING ALL STEEL FITTING WILL BE PHOSPHATE OR GALVANIZED OR ALUMINUM SPRAYED OR COATED WITH PAINT PRIMING RED OXIDE ZINC CHROME AMMUNITION AIR DRYING MATT FINISH, BRUSHING/SPRAYING TO SPEC. JSS 1-63-05 FOLLOW BY A FINISHING COAT OF READY MIXED PAINT OLIVE GREEN AIR DRYING, BRUSHING /SPRAYING/DIPPING MATT FINISH TO SPECN. IS:16B (LATEST ISSUE) (AS APPLICABLE FOR DEFENCE USE) SHADE OF PAINT GREEN OLIVE TO (IS:5-ISC-220)

THE PAINT MUST BE APPLIED EVENLY & EACH COAT MUST BE THOROUGHLY DRIED BEFORE THE APPLICATION OF THE NEXT COAT.

- PROTECTIVE FINISH :
1. PHOSPHATING TO SPECIFICATION IS 1279, CLASS II
  2. POLYSTER POWDER COATING OF 60-80 MICRON

ALL FOAMS TO BE STUCK WITH APPROVED ADHESIVE.  
 LID & BODY- 1.25 mm THK. OTHER AS GIVEN.

NOTE: -  
 EMBOSSING/PAINTING :-  
 FONT SIZE 20MM, FONT TYPE : AERIAL  
 AND COLOR GLOSSY YELLOW "125MM FSAPDS PRAC PRIMARY CARTRIDGE"  
 RECOGNIZED TRADE MARK  
 DATE OF MANUFACTURE (MM/YYYY)  
 PULL OF LOAD 250KG MINIMUM

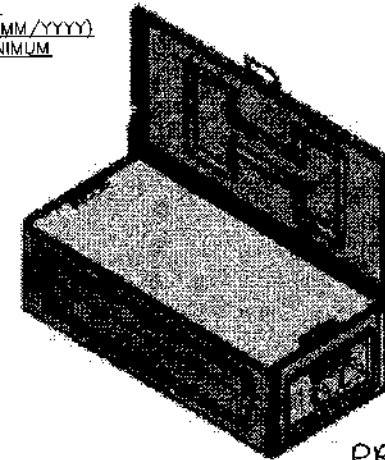

PROVISIONAL

7	COLD ROLLED LOW CARBON STEEL SHEETS & STRIP	2	LIMIT BAR	
6	ANTISTATIC EXPANDABLE POLYETHYLENE FOAM	1	FOAM BOTTOM	
5	ANTISTATIC EXPANDABLE POLYETHYLENE FOAM	1	FOAM TOP	
4	COLD ROLLED LOW CARBON STEEL SHEETS & STRIP	2	HOOK ASSY.	
3	COLD ROLLED LOW CARBON STEEL SHEETS & STRIP	1	TOP COVER ASSY.	
2	COLD ROLLED LOW CARBON STEEL SHEETS & STRIP	2	SIDE HANDLE ASSY.	
1	COLD ROLLED LOW CARBON STEEL SHEETS & STRIP	1	STEEL BOX SUB ASSY.	

ITEM NO	MATERIAL AS STATED	NO.OFF	NOMENCLATURE	REMARKS
<p>MASS: -</p> <p>ORDNANCE FACTORY CHANDA</p> <p>STEEL BOX ASSEMBLY</p>				
PREPD.BY	SUBRO	05.10.23		
OIC/R&D	B/110	ASSLY. & STORE DRG. NO. - PACKING BOX FOR ROUND 125MM HE		
DO/R&D	10/11	DRG. NO.: - PROP/5K-845-02		
OIC/U-VII	14/10	DATE :- 05.10.23		
DO/U-VII	an leave	SCALE: 1:2		
GO/U-VII	an leave			

PROVISIONAL

PHOSPHATING TO IS SPECN. 9618-1986, TO CLASS A2.

O.A.NO	DETAILS	INTL.
DATE		
	REVISIONS	

PROVISIONAL

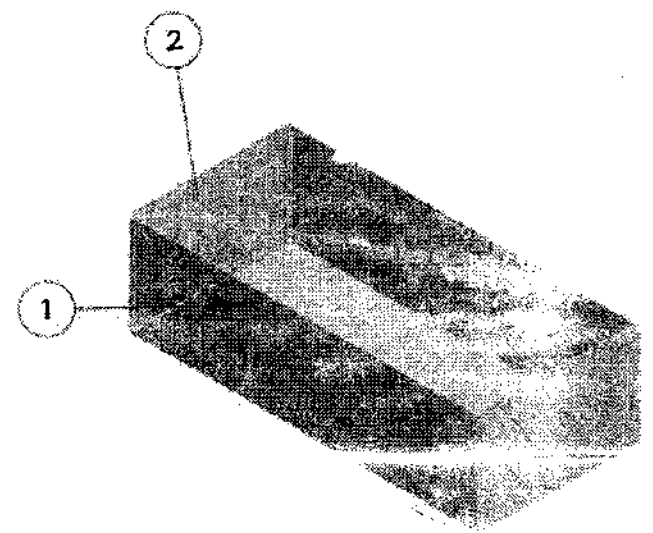
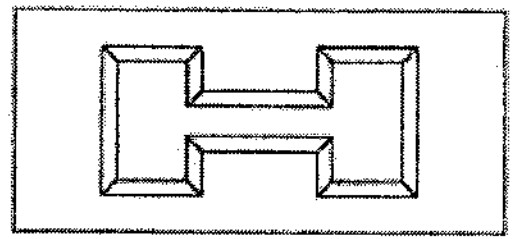
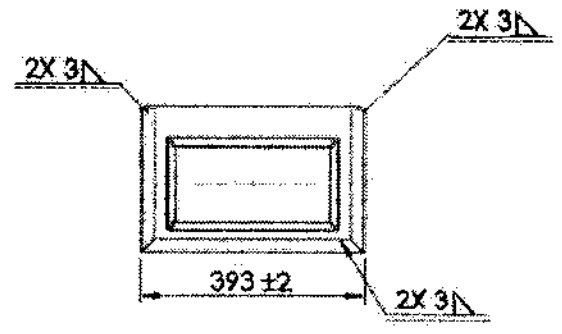
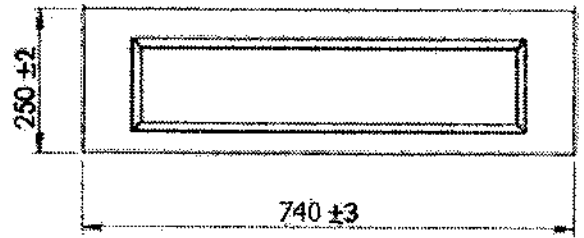

NOTE :- THIS DRG. IS PREPARED FROM DRG. PROVIDED BY U- VIII PHOSPATING TO IS. SPECN: 9618-1996 TO CLASS A2

PROVISIONAL

D.A. NO	DETAILS	DATE
	REVISIONS	

2	COLD ROLLED LOW CARBON STEEL	2	SIDE PLATE	
1	COLD ROLLED LOW CARBON STEEL	1	BASE PLATE	
ITEM NO	MATERIAL AS STATED	NO.OFF	NOMENCLATURE	REMARKS
MASS: —			<b>आयुध निर्माणा, चाँदवा</b> CHANDIGARH FACTORY CHANDIA	
			<b>STEEL BOX SUB ASSEMBLY</b>	
PREPD. BY	SIGN	DATE	ASSLY. & STORE DRG. NO. —	
OIC/R&D	<i>[Signature]</i>	05.10.23	PACKAGING BOX FOR ROUND 125MM HE	
DO/R&D	<i>[Signature]</i>	5/10	DRG. NO. :- PROP/SK-845-05	
□ D.O/U-VII	<i>[Signature]</i>	5/10	DATE :- 05/10/23	
□ D.O/U-VIII	<i>[Signature]</i>	6/10		
□ D.O/U-VI				

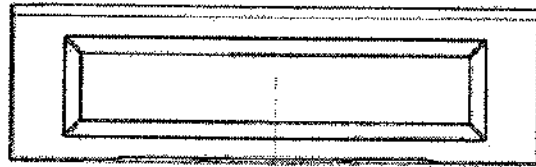

SECTION B-B  
SCALE: 1:8

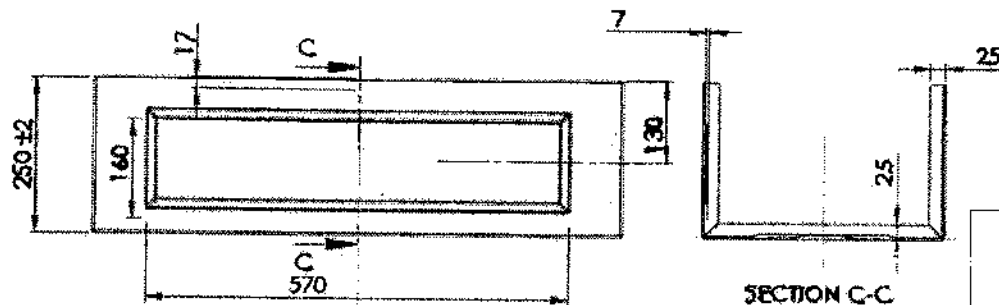
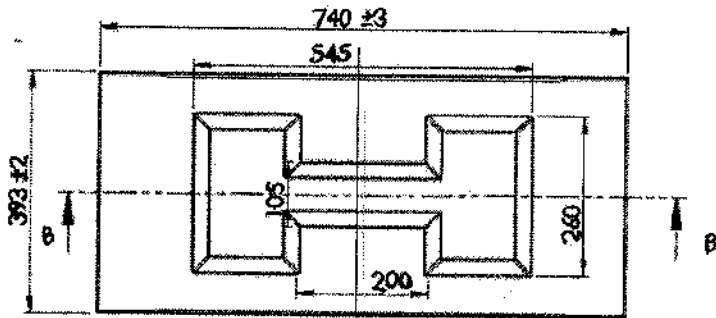
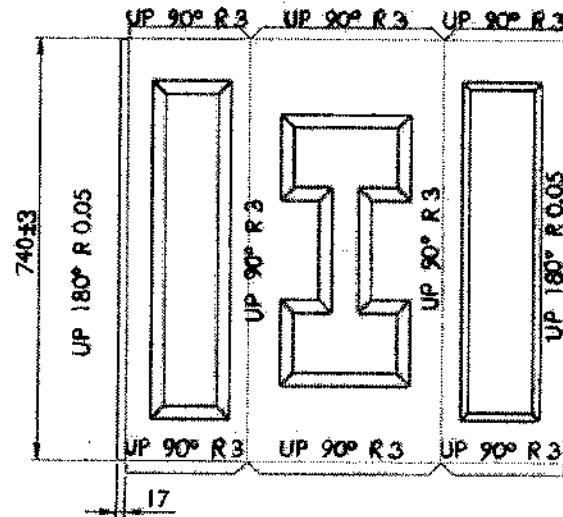

SECTION C-C  
SCALE: 1:8

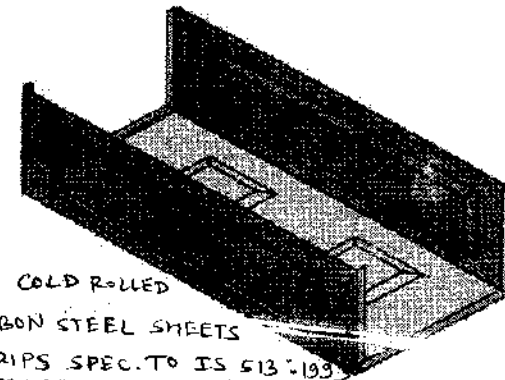

MATL: - COLD ROLLED  
LOW CARBON STEEL SHEETS  
AND STRIPS SPEC. TO IS 513:1983  
REAFFIRMED 2003. ANY OF GR. 0/D/D/D.

NOTE :- THIS DRG. IS PREPARED FROM DRG. PROVIDED  
By U- VIII

PHOSPHATING TO IS: 3618-1996 TO CLASS A2

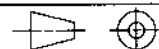
ITEM NO	MATERIAL AS STATED	NO.OFF	NOMENCLATURE	REMARKS
			आयुध निर्माणी, चांदा ORDNANCE FACTORY CHANDA	
MASS: -			BASE PLATE	
				
		SIGN	DATE	
PREPD. BY			05.10.23	
OIC/R&D				ASSLY. & STORE DRG. NO. - PACKAGING BOX FOR ROUND 125MM HE
DO/R&D				DRG. NO.: - PROP/SK-845-04
APPROVED	OIC/U-VII		5/10	
	DO/U-VIII		6/10	
	GO/U-VIII			
D.A.NO	DETAILS	INTL.		
DATE				
	REVISIONS			

PROVISIONAL

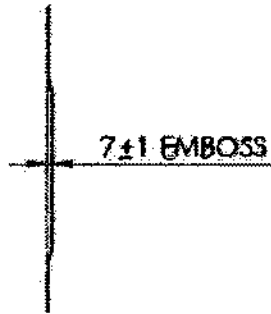
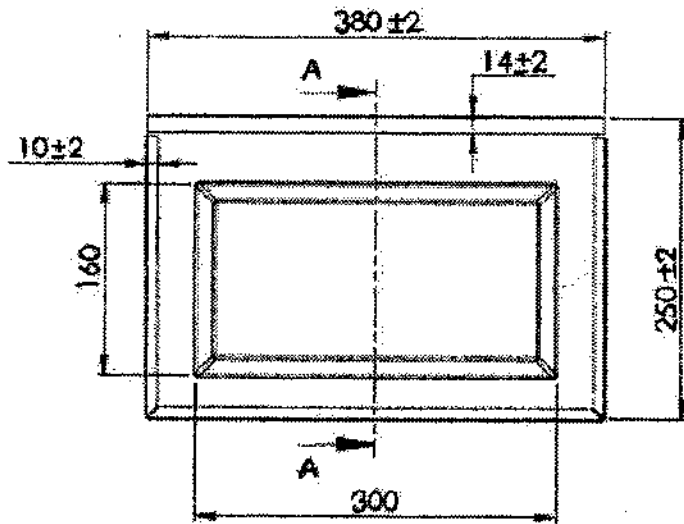

SECTION A-A

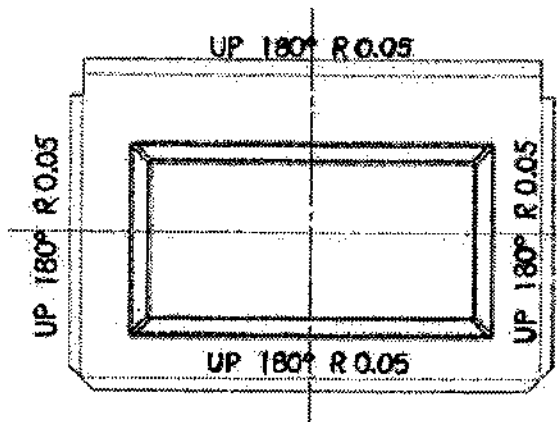
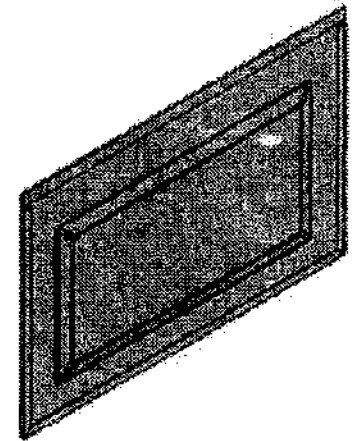

MATL:- COLED ROLLED LOW CARBON STEEL SHEETS AND STRIPS SPEC. TO IS 513:1933, REAFFIRMED 2003, ANY OF GR. 0/D/DD.

PHOSPHATING TO IS: 3618:1996 TO CLASS A-2

PROVISIONAL

NOTE :- THIS DRG. IS PREPARED FROM DRG. PROVIDED BY U- VIII

ITEM NO.	MATERIAL AS STATED	NO.OFF	NOMENCLATURE	REMARKS
			आयुध निर्माणी, चांदा MUNICIPALITY FACTORY CHANDA	
MASS:-			SIDE PLATE	
PREPD.BY	SIGN	DATE		
OIC/R&D	<i>[Signature]</i>	05.10.23	ASSLY.& STORE DRG. NO.- PACKAGING BOX FOR ROUND 125MM HE	
DO/R&D	<i>[Signature]</i>	05/10	DRG. NO.:- PROP/ISK-845-05	
APPROVED	OIC/U-VII	05/10	DATE:- 05.10.23	
	DO/U-VII	05/10	SCALE:- 1:1	
	GO/U-VII			
D.A.NO	DETAILS	INTL.		
DATE	REVISIONS			

PROVISIONAL

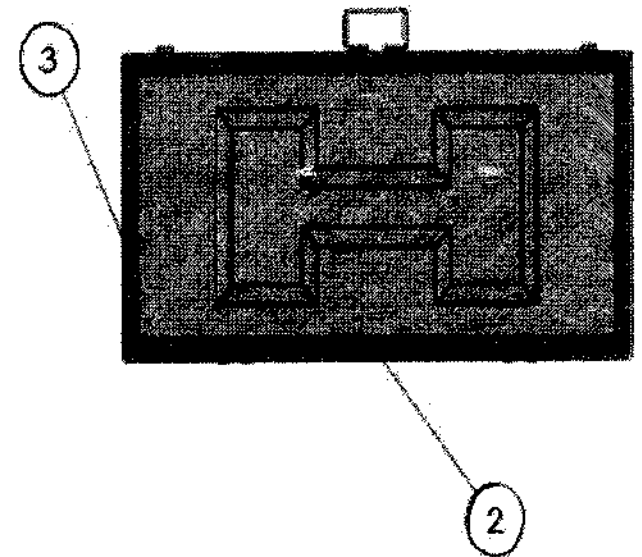
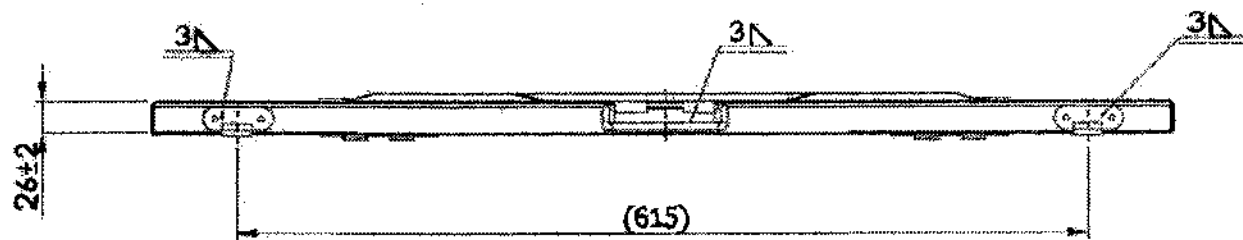
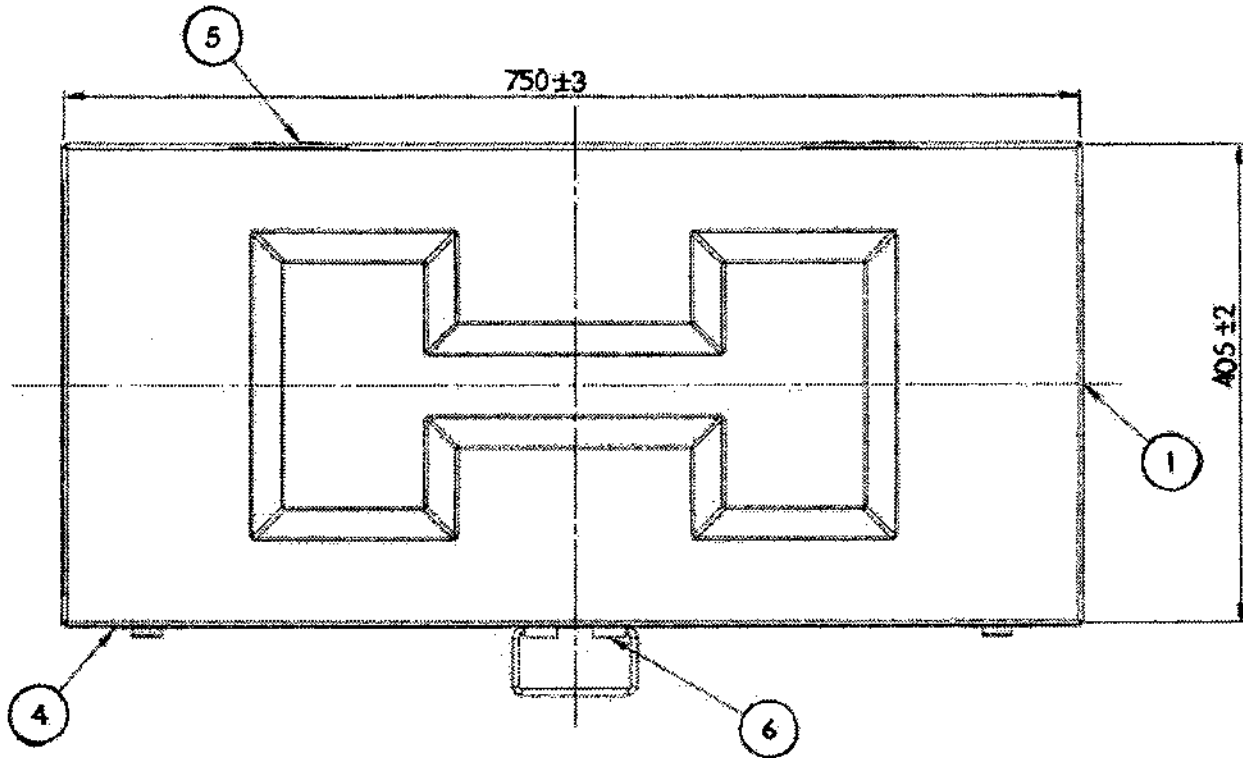

6		1	TOP COVER HANDLE ASSY.	
5		2	HING ASSY.	
4	COLLED ROLLED TO CARBON STEEL	2	HOOK HOLDER TOP PLATE	
3	EPDM SPONGE	2	GASKET 2	
2	EPDM SPONGE	2	GASKET 1	
1	COLLED ROLLED TO CARBON STEEL	1	TOP COVER	

PROVISIONAL

ITEM NO	MATERIAL	NO.OFF	NOMENCLATURE	REMARKS
<p>MASS: -</p> <p>APPROVED BY: [Signature]</p> <p>DATE: 05.10.23</p> <p>SIGN: [Signature]</p> <p>DATE: 05.10.23</p>				
			<p>आयुध निर्माणी, चांदा</p> <p>ORDNANCE FACTORY CHANDA</p>	
				<p>TOP COVER ASSEMBLY</p>
PREP.D.BY		[Signature]	ASSLY.& STORE DRG. NO.- PACKING BOX FOR ROUND 125MM HE	
OIC/R&D		[Signature]	DRG. NO.: - PROP/ISK - 845 - 06	
DO/R&D		[Signature]	DATE :- 05.10.23	
OIC/U-VII		[Signature]	SCALE :- 1:1	
APPROVED		[Signature]		

NOTE :- THIS DRG. IS PREPARED FROM DRG. PROVIDED BY U- VIII

D.A.NO	DETAILS	INTL.
	REVISIONS	

PROVISIONAL

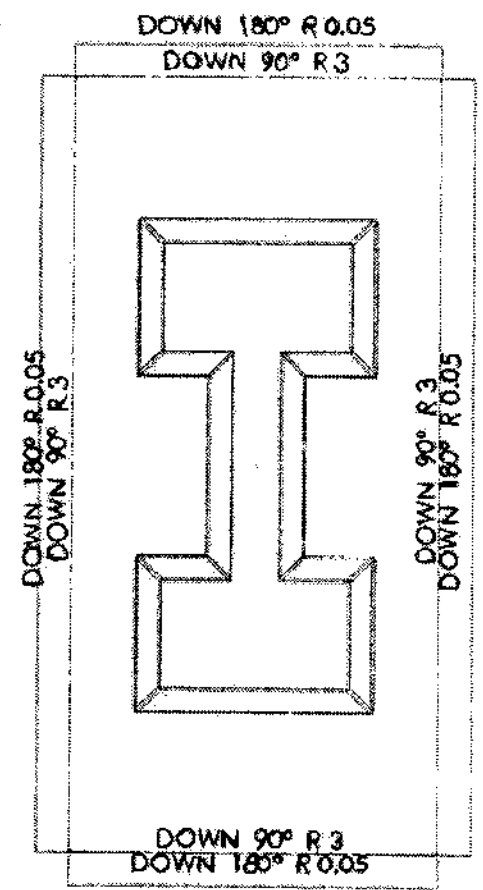
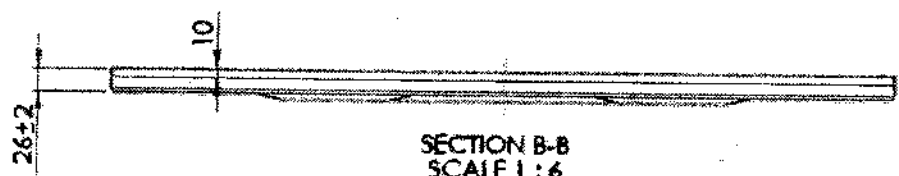
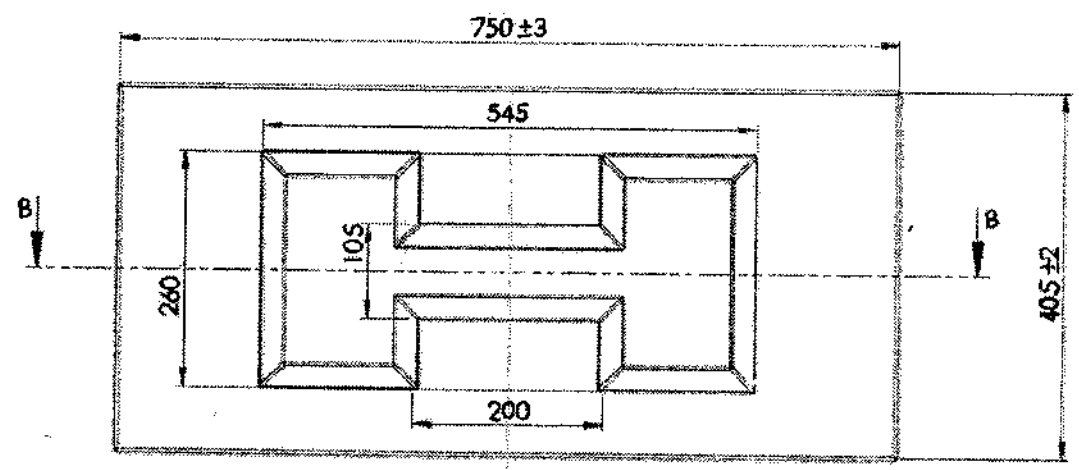

MAT: - COILED ROLLED CARBON STEEL SHEETS & STRIPS SPEC. TO IS 513:1993 REAFFIRMED 2003, ANY OF GR. 01D/DD

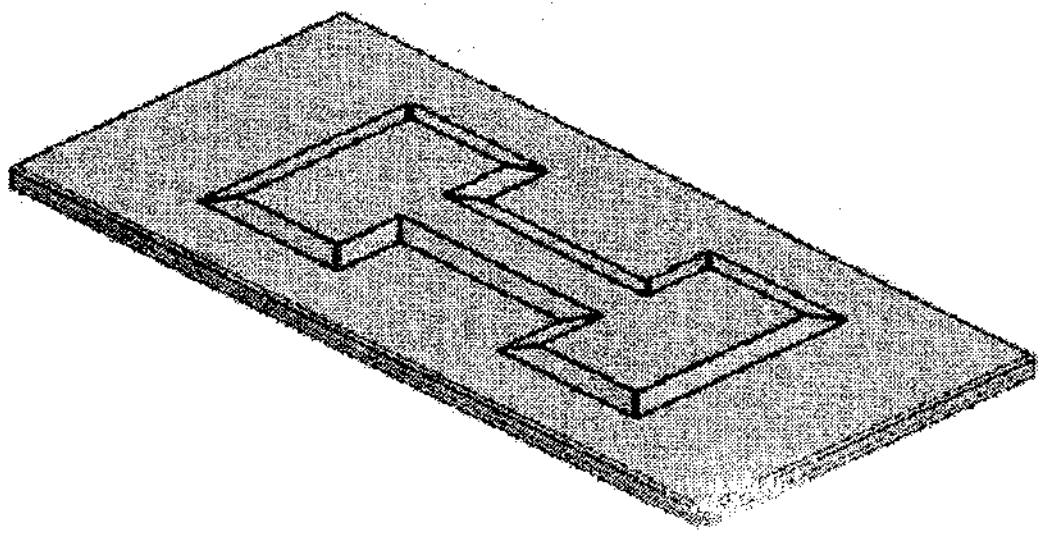

NOTE:- THIS DRG. IS PREPARED FROM DRG. PROVIDED BY U-VIII PHOSPHATING TO IS SPECN. 3618-1986, TO CLASS A2

ITEM NO	MATERIAL	NO.OFF	NOMENCLATURE	REMARKS
	AS STATED		आयुध निर्माणी, चाँदा	
	MASS: -		ORDNANCE FACTORY CHANDA	
			TOP COVER	
	SIGN	DATE		
PREPD.BY	<i>[Signature]</i>	05.10.23		
OIC/R&D	<i>[Signature]</i>	5/10		ASSLY. & STORE DRG. NO. -
DO/R&D	<i>[Signature]</i>	5/10		PACKAGING BOX FOR ROUND 125MM
OIC/U-VIII	<i>[Signature]</i>	5/10		DRG. NO. - PROP/ISK-845-07
DO/U-VIII	<i>[Signature]</i>	6/10		
GEN. DRG.				SCALE - 1:6

PROVISIONAL

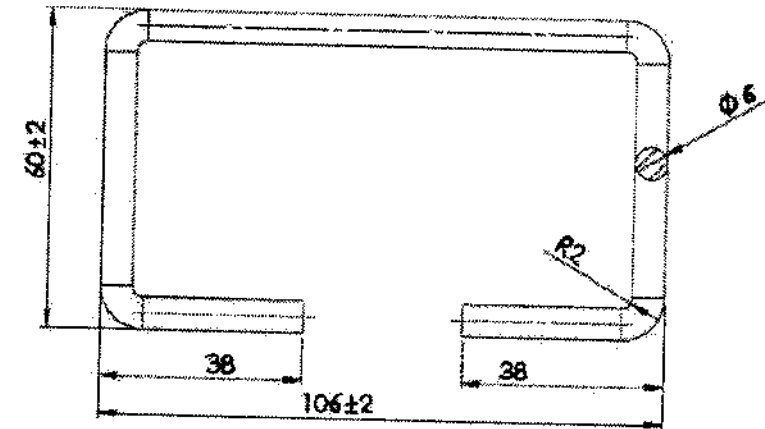

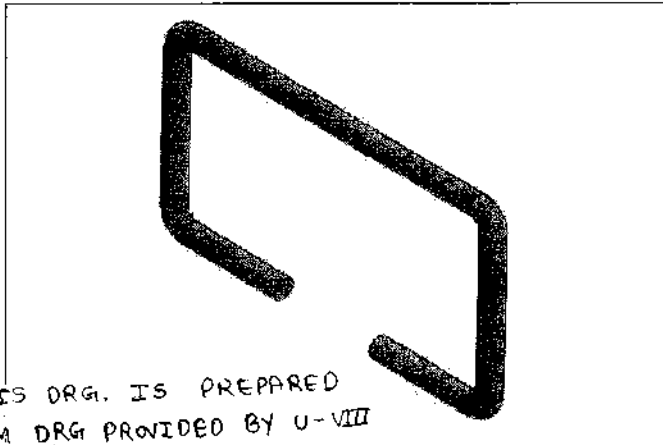

MATL: HOT ROLLED MEDIUM AND HIGH TENSILE STRUCTURAL STEEL TO IS 2062:2011, GRADE E 250

PHOSPATING TO SPECN. IS: 3618-1996, TO CLASS A2.



NOTE - THIS DRG. IS PREPARED FROM DRG PROVIDED BY U-VIII

ITEM NO.		MATERIAL		NO.OFF	NOMENCLATURE	REMARKS
		AS STATED			 आयुध निर्माणी, चांदा ORDNANCE FACTORY CHANDA	TOP COVER HANDLE
		MASS: -				
						
		SIGN		DATE		
		PREPD. BY		05.10.23		
		OIC/R&D		ASSLY. & STORE DRG. NO. -		
		DO/R&D		PACKAGING BOX FOR ROUND 125MM HE		
		OIC/U-VIII		DRG. NO.: - PROP/SK-845-08		
		DO/U-VIII		DATE: - 05.10.23		
		GO/U-VIII		SCALE: - 1:2		
D.A. NO	DETAILS	INTL.				
DATE	REVISIONS					



PROVISIONAL

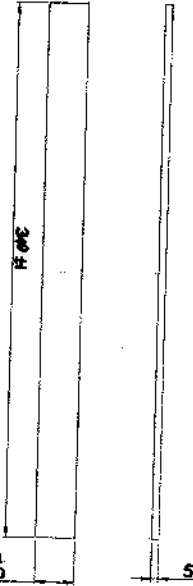

MATL:- EPDM SPONGE

HARDNESS SHORE A

SP GRAVITY : 0.6 to 0.95

25.0

5

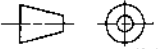

NOTE :- THIS DRG. IS PREPARED FROM DRG. PROVIDED BY U-VIII

		ITEM NO	MATERIAL	NO.OFF	NOMENCLATURE	REMARKS
		EPDM SPONGE			 आयुध निर्माणी, चांदा ORDNANCE FACTORY CHANDA	
		MASS:-				
					GASKET 2	
			SIGN	DATE		
		PREPD.BY	<i>[Signature]</i>	05.10.23	ASSLY.& STORE DRG. NO.- PACKAGING BOX FOR ROUND 125MM HE	
		DO/R&D	<i>[Signature]</i>	5/10	DRG. NO.: - PROP/SK - 845-1a	
D.A.NO	DETAILS	INTL.	APPROVED	DO/U-VII	5/10	DATE :- 05.10.23
DATE			DO/U-VIII	6/10		SCALE: - 1:1
REVISIONS			GO/U-VIII	-	-	

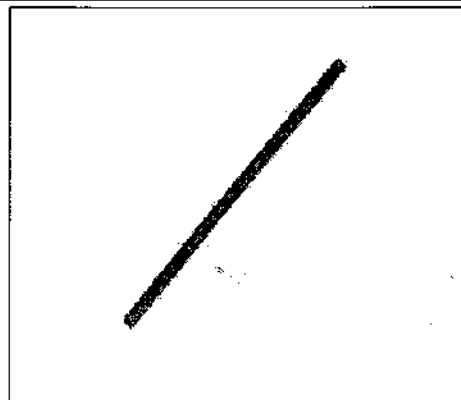

PROVISIONAL

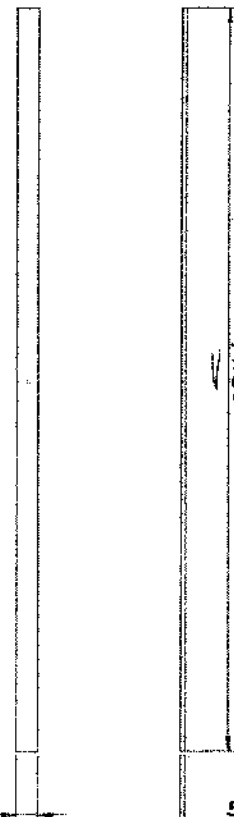

PROVISIONAL

MATL: EPDM SPONGE

SPECIFIC GRAVITY = 0.16 to 0.95

HARDNESS SHORE A

$\begin{matrix} +1 \\ 25.0 \end{matrix}$

5

NOTE :- THIS DRG. IS PREPARED FROM DRG. PROVIDED BY - U-VIII

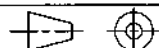
		ITEM NO	MATERIAL	NO. OFF	NOMENCLATURE	REMARKS
		AS STATED		 आयुध निर्माणी चांदा ORDNANCE FACTORY CHANDA		GASKET 1
		MASS: -				
						
			SIGN	DATE		
		PREPD. BY	<i>[Signature]</i>	05.10.23		
		OIC/R&D			ASSLY. & STORE DRG. NO. - PACKAGING BOX FOR ROUND 125MM HE	
		DO/R&D	<i>[Signature]</i>	STP	DRG. NO.: - PROP/SK - 845-11	
D.A. NO	DETAILS	INTL.	APPROVED	OIC/U-VI	DO/U-VII	GO/U-VIII
				<i>[Signature]</i>	05.10	DATE :- 05.10.23
REVISIONS						SCALE: - 2:1







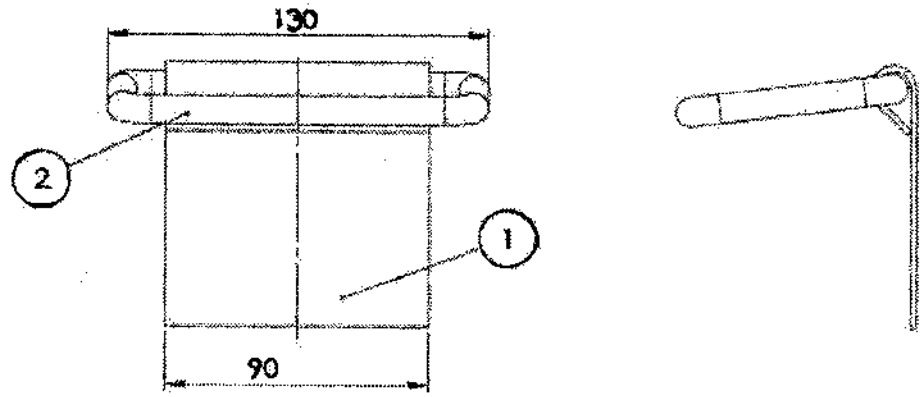

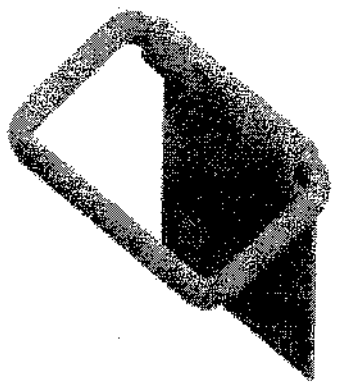

PROVISIONAL



PHOSPATING TO IS SPECN. 3618-1996, TO CLASS A2.

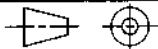

NOTE :- THIS DRG. IS PREPARED FROM DRG. PROVIDED BY U-VIII

2	COLLED RINGED WELD	1	SIDE HANDLE PLATE	
1	DET RINGED WELD WITH TENSILE STRENGTH	1	SIDE HANDLE	
ITEM NO	MATERIAL AS STATED	NO.OFF	NOMENCLATURE	REMARKS
MASS: -		 आयुध निर्माणी, चांदा ORDNANCE FACTORY CHANDA		
		SIDE HANDLE ASSEMBLY		
	SIGN	DATE		
PREPD.BY		05.10.23		
OIC/R&D		5/10	ASSLY. & STORE DRG. NO. -	
DO/R&D		5/10	PACKAGING BOX FOR ROUND 125MM HE	
APPROVED	OIC/U-VII		DRG. NO.: - PROP/5K-845-14	
	DC, U-VIII	6/10	DATE :- 05.10.23	
	GO/U-VII	-	SCALE: - 1:1	
D.A.NO	DETAILS	INTL.		
	REVISIONS			

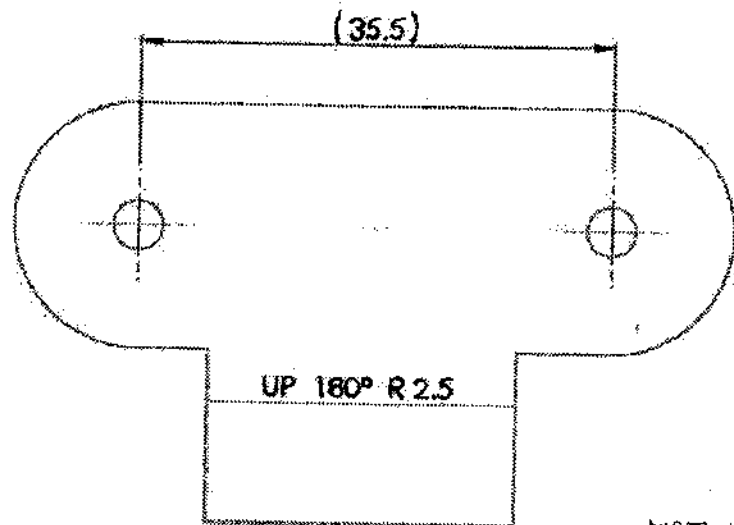
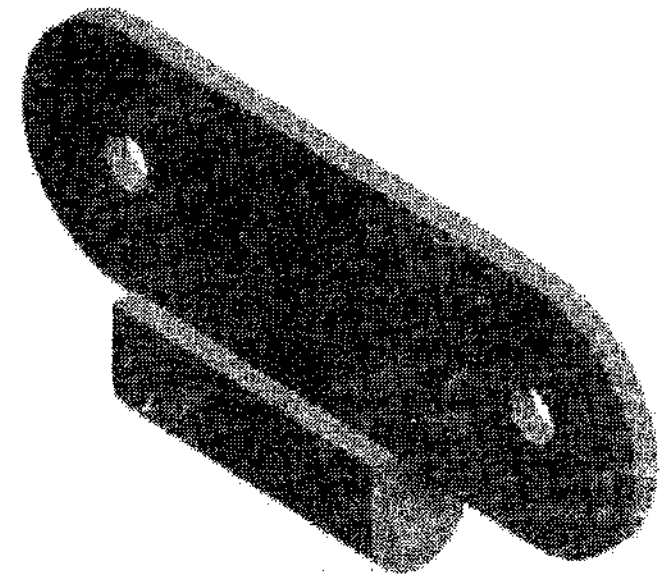
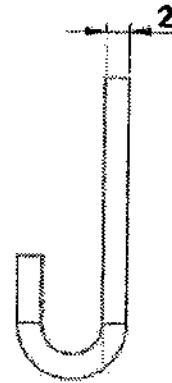
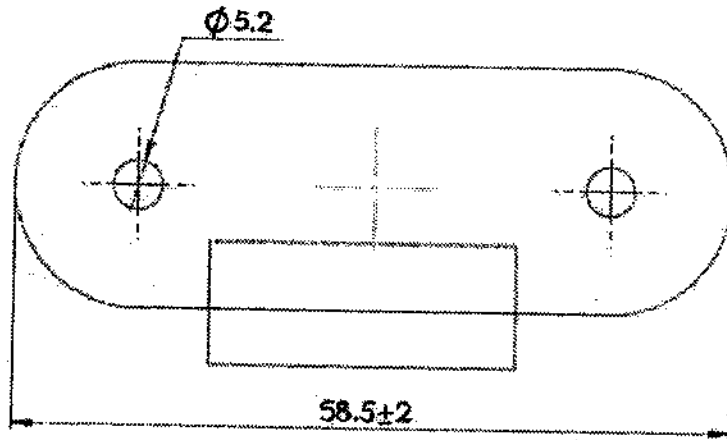

MATL :- COLD ROLLED

LOW CARBON STEEL SHEETS AND STRIPS SPEC. TO IS 513:1993, REAFFIRMED 2003, ANY OF GR.O/D/PD



NOTE :- THIS DRG. IS PREPARED FROM DRG. PROVIDED BY U-VIII

PHOSPHATING TO IS: SPECN. 3618-1996 TO CLASS-A2

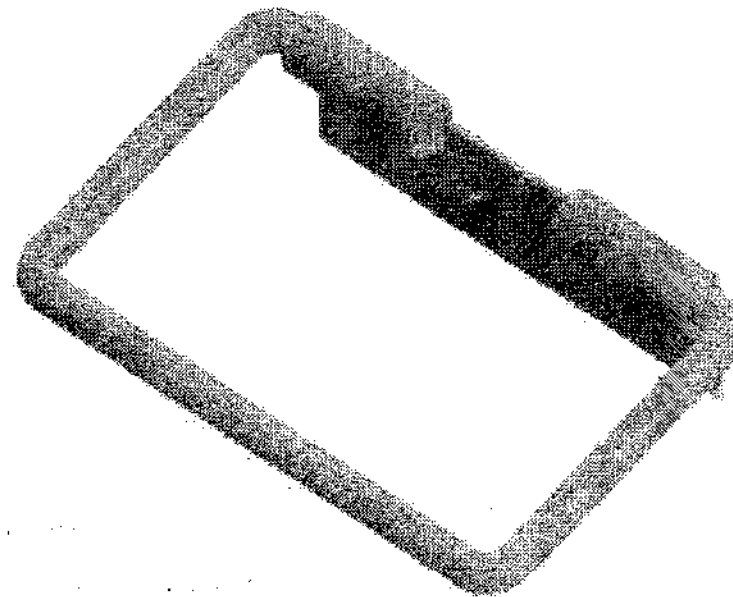
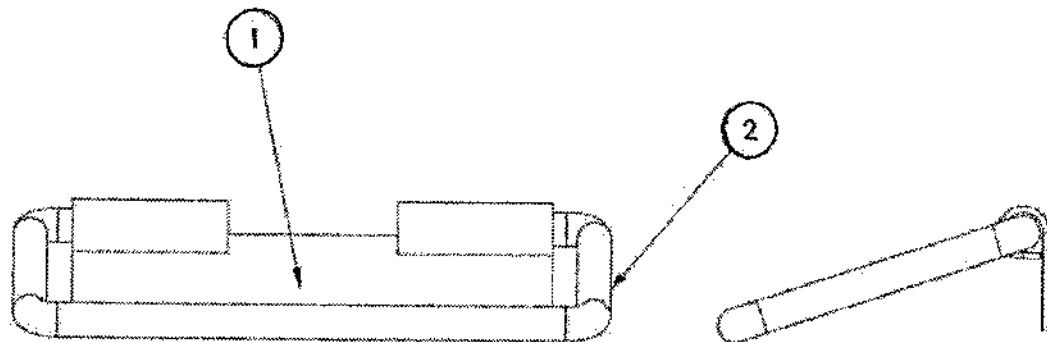
ITEM NO	MATERIAL	NO.OFF	NOMENCLATURE	REMARKS
	AS STATED		आयुध निर्माणी, चांदा ORDNANCE FACTORY CHANDA	
MASS: -				
	SIGN	DATE	HOOK HOLDER TOP PLATE	
PREPD.BY		05.10.23		
GIC/R&D		SJD	ASSLY. & STORE DRG. NO. - PACKAGING BOX FOR ROUND 125MM HE	
DO/R&D		SJD	DRG. NO. :- PROP 15K - 845 - 15	
APPROVED	GIC/U-VII			
	DO/U-VII	6/10	DATE :- 05.10.23	
	GO/AI-VIII		SCALE :- 1:1	
D.A.NO	DETAILS	INTL.		
DATE	REVISIONS			



PROVISIONAL

2	HOT ROLLED STEEL	1	TOP COVER HANDLE	STD
1	COLD ROLLED STEEL	1	TOP COVER HANDLE PLATE	STD
ITEM NO	MATERIAL	NO.OFF	NOMENCLATURE	REMARKS
	AS STATED			
MASS: -			 <b>आयुध निर्माणी, चांदा</b> <b>ORDNANCE FACTORY CHANDA</b>	
			<u>TOP COVER HANDLE</u> <u>ASSEMBLY</u>	
PREP.D BY	SIGN	DATE		
	<i>[Signature]</i>	05.10.23		
OIC/R&D	<i>[Signature]</i>	5/10	ASSLY. & STORE DRG. NO. - PACKING BOX FOR ROUND 125MM HE	
DO/R&D	<i>[Signature]</i>	5/10	DRG. NO.: - PROP/5K-845-16	
APPROV	OIC/U-VII	<110		
	DO/U-VIII	6/10	DATE: - 05.10.23	
	GO/U-VIII	-	SCALE: - 1:1	

NOTE :- THIS DRG. IS PREPARED FROM DRG. PROVIDED BY U-VIII



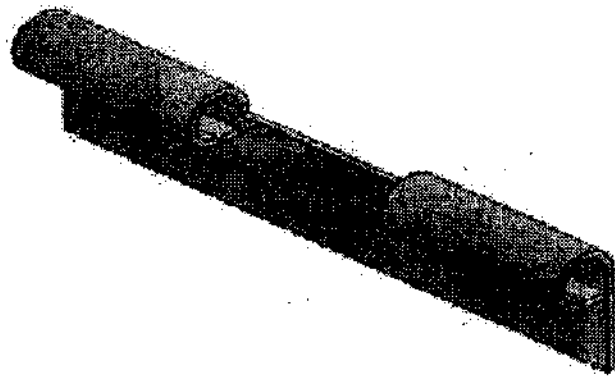
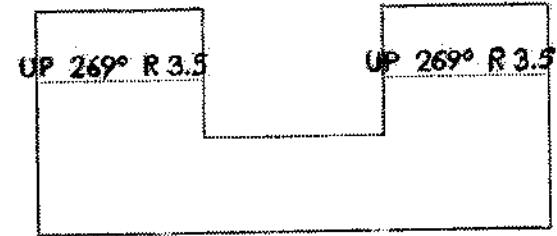
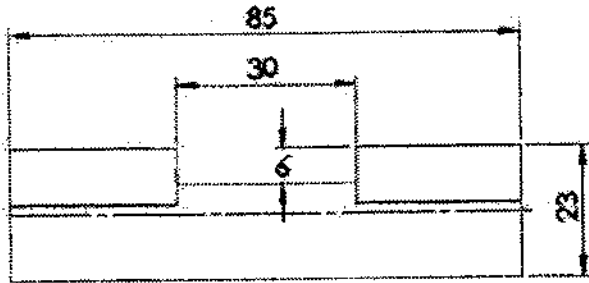



D.A. NO	DETAILS	INTL.
DATE		
REVISIONS		



MATL :- COLD ROLLED LOW CARBON  
STEEL SHEETS & STRIPS  
SPEC. TO IS: 513: 1993,  
REAFFIRMED 2003, ANY OF  
GRADE 01D/00

PHOSPATING TO SPECN. IS-3618-1996 TO CLASS A2

NOTE :- THIS DRG. IS PREPARED FROM DRG. PROVIDED  
By U-VIII

O.A. NO.		ITEM NO.		MATERIAL		NO.OFF		NOMENCLATURE		REMARKS	
				AS STATED				 आयुध निर्माणी, चांदा ORDNANCE FACTORY CHANDA			
				MASS: -				  TOP COVER HANDLE PLATE			
				SIGN		DATE					
		PREPD. BY				05.10.23					
		OIC/R&D				5/10		ASSLY. & STORE DRG. NO. -			
		DO/R&D				5/10		PACKAGING BOX FOR ROUND 125MM HE			
		OIC/U-VII				5/10		DRG. NO. :- PROP/ISK-845-17			
O.A. NO.		DATE		DETAILS		F.T.L.		APPROVED		SCALE: - 1:1	
								DO/U-VIII		UPD. DATE: 11.23	
								CO/U-VIII			
				REVISIONS							





PROVISIONAL

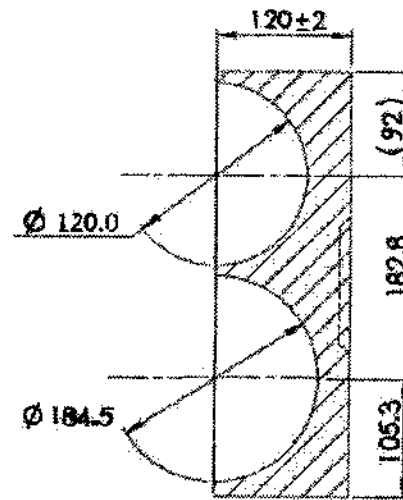
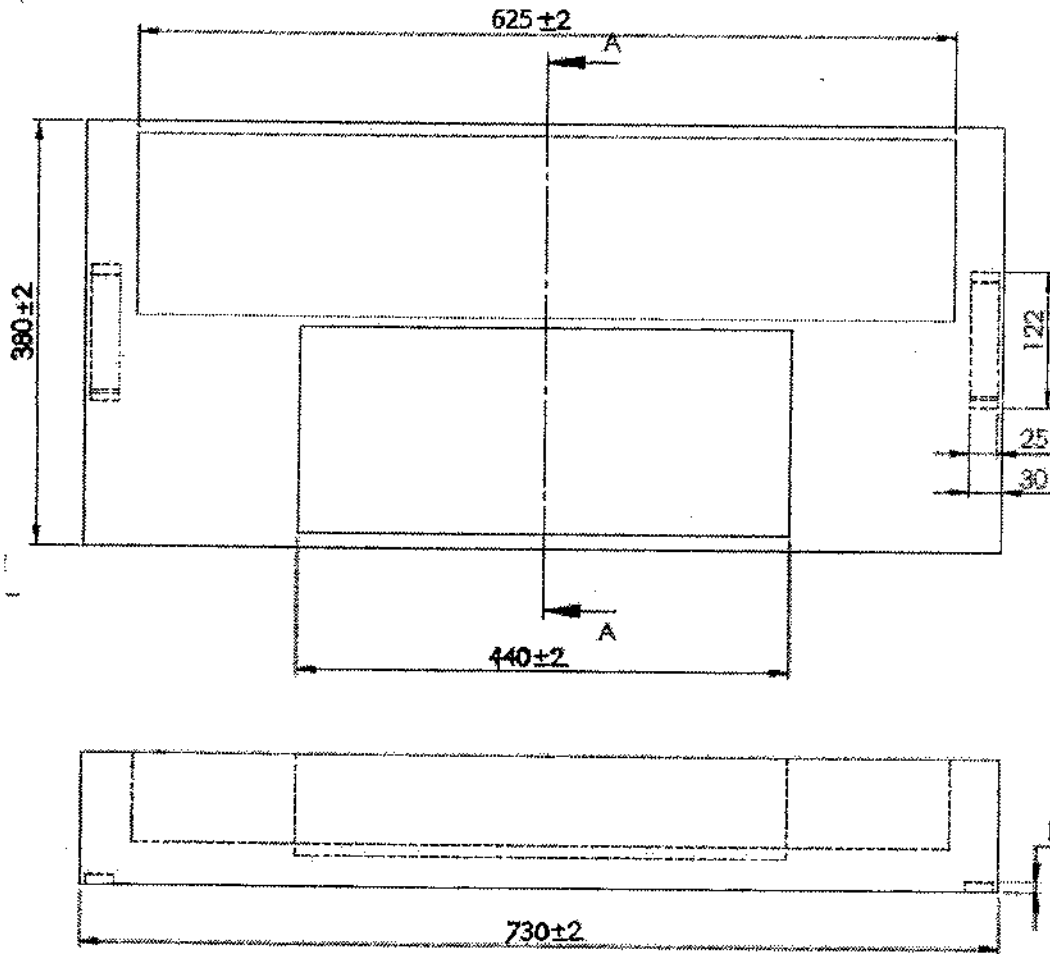

SECTION A-A

NOTES :-

1. DENSITY : 30KG/M<sup>3</sup>
2. AL FOIL THICKNESS MIN 25MICRON TO BE WRAPPED AROUND THE FOAM WITH PROPER ADHESION

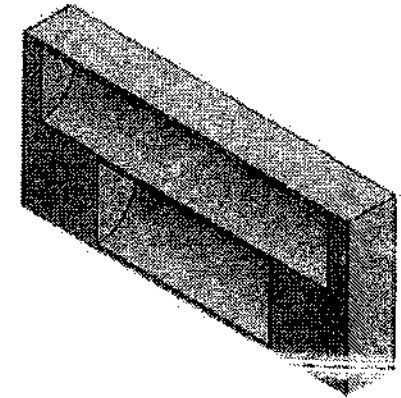

MATL :- PU FOAM OF ANTI-STATIC EXPANDED POLYETHYLENE  
 SPEC. IMD/ME/913 (9) Provisional : 2004  
 MOULDING / CUTTING IN MOULDING SHAPE  
 POLYURETHANE (PU) FOAM DENSITY : 30 ± 5 Kg/m<sup>3</sup>.

NOTE :- THIS DRG. IS PREPARED FROM DRG. PROVIDED  
 BY U- VII

PROTECTIVE FINISH : ALUMINIUM FOIL

PROVISIONAL

ITEM NO	MATERIAL	NO.OFF	NOMENCLATURE	REMARKS
1	AS STATED		ऑडिट निर्माणी, चांदा ORDNANCE FACTORY CHANDRA	
MASS :-				
PREP.D BY	SIGN	DATE	FOAM BOTTOM	
OIC/R&D	<i>[Signature]</i>	05.10.23	ASSLY. & STORE DRG. NO. - PACKAGING BOX FOR ROUND 125MM HE	
DO/R&D	<i>[Signature]</i>	5/10		
OIC/U-VII	<i>[Signature]</i>	5/10	DRG. NO. :- PROP/ISK-845-19	
DO/U-VII	<i>[Signature]</i>	6/10	DATE :- 05.10.23	
DO/U-VIII	<i>[Signature]</i>	-	SCALE :- 1:1	
D.A. NO DATE	DETAILS	INTL.	REVISIONS	

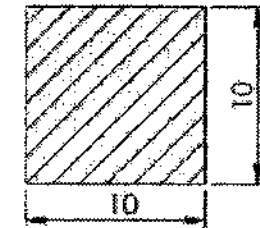
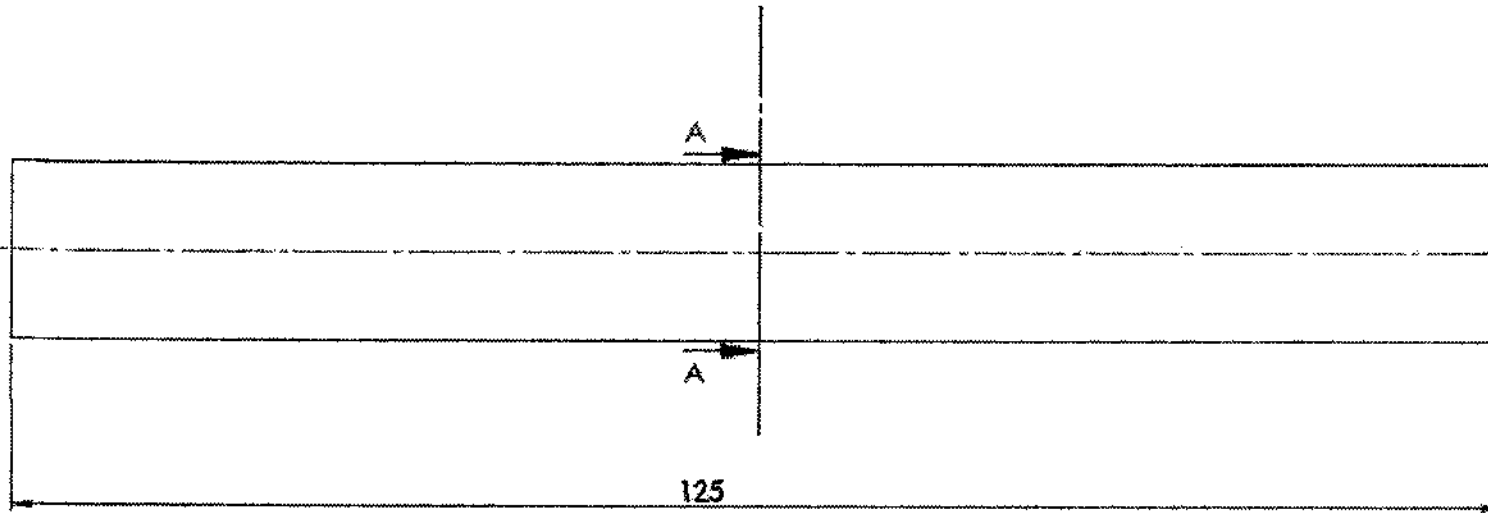

SECTION A-A  
SCALE 2:1



MATL: HOT ROLLED MEDIUM AND HIGH TENSILE STRUCTURAL STEEL TO IS 2062 : 2011, GRADE E250

NOTE :- THIS DRG. IS PREPARED FROM DRG. PROVIDED BY U-VIII

PROTECTIVE FINISH: PHOSPHATING TO IS:3618-1996 TO CLASS A2

D.A.NO DATE	DETAILS	INTL.	ITEM NO	MATERIAL	NO.OFF	NOMENCLATURE	REMARKS
							As stated
			MASS:-				
			PREP.D.BY	SIGN	DATE		
			OIC/R&D		10.23		
			DO/R&D		5/10		
			APPROVED OIC/U-VII		5/10		
			OIC/U-VIII		6/10		
			6,150/U VII		-		
			REVISIONS				
						ASSLY. & STORE DRG. NO.- PACKAGING BOX FOR ROUND 125MM DIA	
						DRG. NO.:- PROP/ISK - 845 - 20	
						DATE : 05/10/23	
						SCALE :- 2:1	

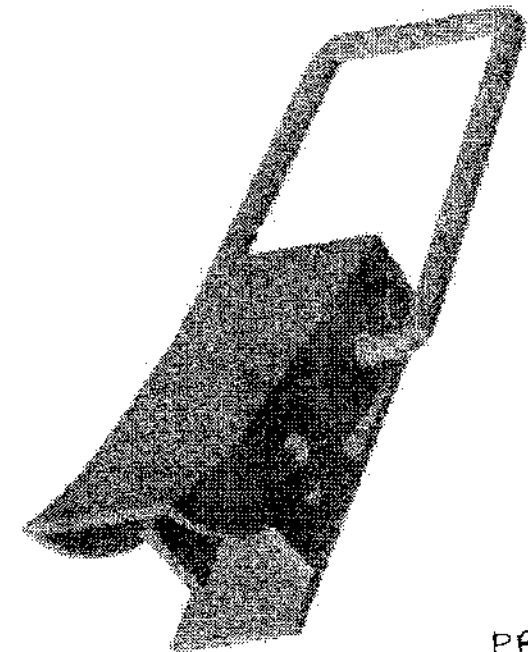
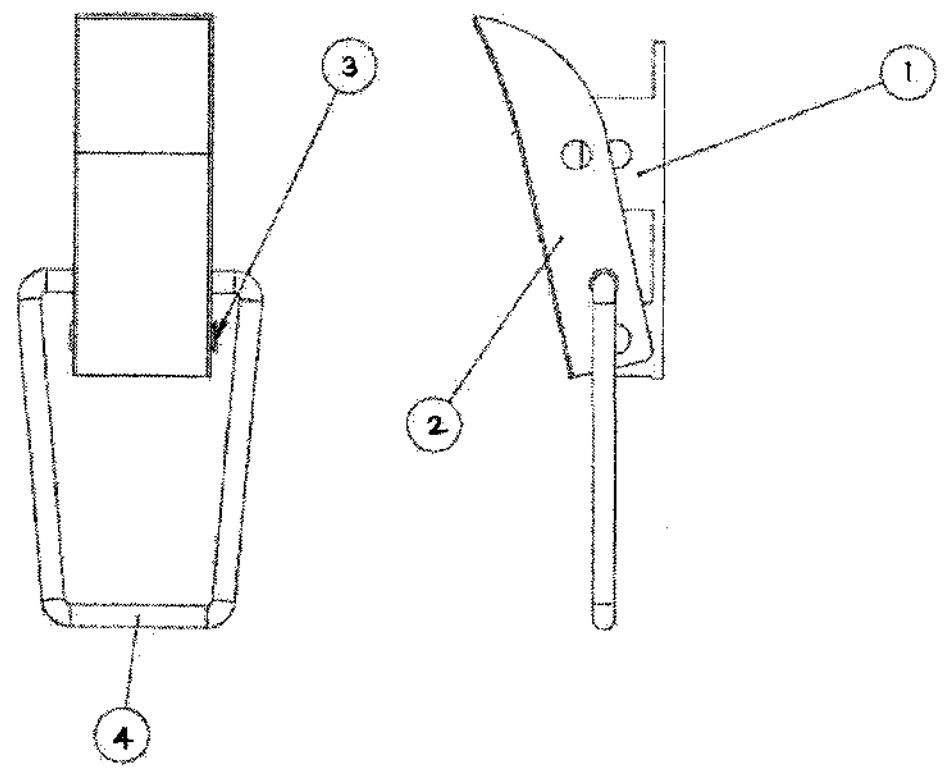

PROVISIONAL

4	COLD ROLLED LOW CARBON STEEL SHEETS	1	HOOK LINK
3	COLD ROLLED LOW CARBON STEEL SHEETS	1	HOOK PIN
2	COLD ROLLED LOW CARBON STEEL SHEETS	1	HOOK HANDLE
1	COLD ROLLED LOW CARBON STEEL SHEETS	1	HOOK BASE PLATE

ITEM NO	MATERIAL AS STATED	NO.OFF	NOMENCLATURE	REMARKS
MASS: - 				
			आयुध निर्माणी, चांदा ORDNANCE FACTORY CHANDA	
HOOK ASSEMBLY				
PREP.D BY	SIGN	DATE	ASSLY. & STORE DRG. NO. - PACKING BOX FOR ROUND 125MM HE	
OIC/R&D		05.10.23		
DO/R&D		05/10		
OIC/U-VII		05/10	DRG. NO.: - PROP/ISK - 845 - 2	
DO/AT		05/10	DATE: - 05.10.23	
GO/IN		-	SCALE: 1:1	

D.A. NO	DETAILS	INTL.
DATE	REVISIONS	

NOTE :- THIS DRG. IS PREPARED FROM DRG. PROVIDED BY U - VIII



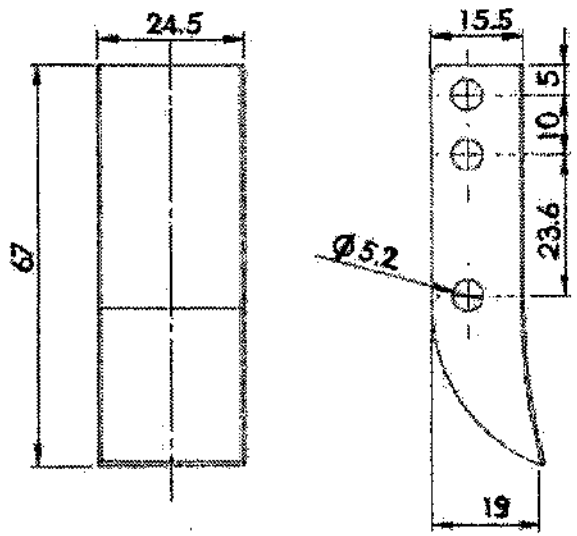

PROVISIONAL

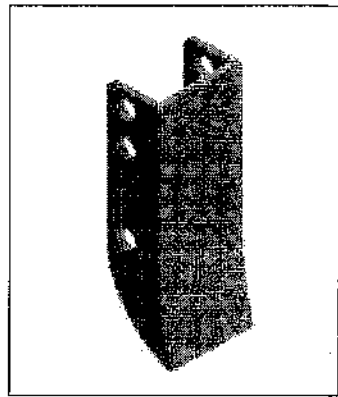
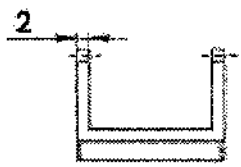

MATL: COLD ROLLED LOW CARBON STEEL SHEETS & STRIPS - SPEC. TO IS 513:1993, REAFFIRMED 2003, ANY OF GRADE 0'DIDD.

NOTE :- THIS DRG. IS PREPARED FROM DRG. PROVIDED BY

U-VIII ② PHOSPATING TO IS: SPECN: 3618-1998. CLASS A2

ITEM NO.	MATERIAL	NO.OFF	NOMENCLATURE	REMARKS
	AS STATED		आयुध निर्माणी, चांदा	
	MASS:-		ORDNANCE FACTORY CHANDA	
			HOOK HANDLE	
	SIGN	DATE		
PREP.O.BY		05.10.23		
OIC/R&D		S/10	ASSLY.& STORE DRG. NO.-	
DO/R&D		S/10	PACKAGING BOX FOR ROUND 125MM HE	
APPROVED	OIC/U-VII	S/10	DRG. NO.:- PROP/ISK-845 -23	
	DO/U-VIII		DATE :-05.10.23	
	GO/U-VIII	-	SCALE:- 2:1	

D.A.NO	DETAILS	INTL.
	REVISIONS	

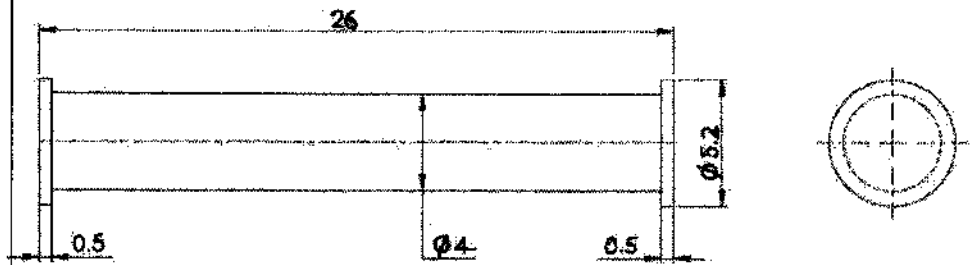

PROVISIONAL

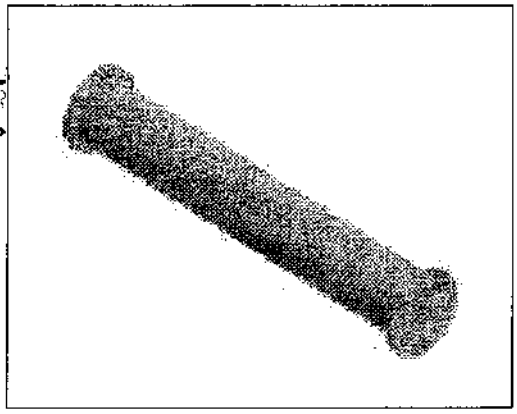

MATL :- HOT ROLLED MEDIUM & HIGH TENSILE STRUCTURAL STEEL TO IS 2062/2011 & ANY OF GRADE E 250  
 PHOSPATING TO SPEEN IS : 3618-2936, TO CLASS A2.



NOTE :- THIS DRG. IS PREPARED FROM DRG. PROVIDED BY U-VIII

		ITEM NO	MATERIAL	NO.OFF	NOMENCLATURE	REMARKS
			AS STATED		 आयुध निर्माणी, चांदा ORDNANCE FACTORY CHANDA	HOOK PIN
		MASS :-				
						
			SIGN	DATE		
		PREPD. BY	<i>[Signature]</i>	05.10.23		
		OIC/R&D	<i>[Signature]</i>	S/110	ASSLY. & STORE DRG. NO. - PACKAGING BOX FOR ROUND 125MM HE	
		DO/R&D	<i>[Signature]</i>	S/110	DRG. NO. :- PROP 1SK-845 - 24	
D.A. NO	DETAILS	INTL.	OIC/U-VII	<i>[Signature]</i>	S/110	DATE :- 05.10.23
	REVISIONS		DO/U-VII	<i>[Signature]</i>	S/110	SCALE :- 2:1
			GO/U-VII	-	-	

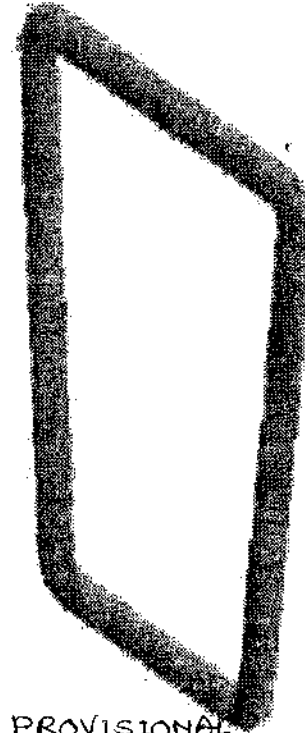
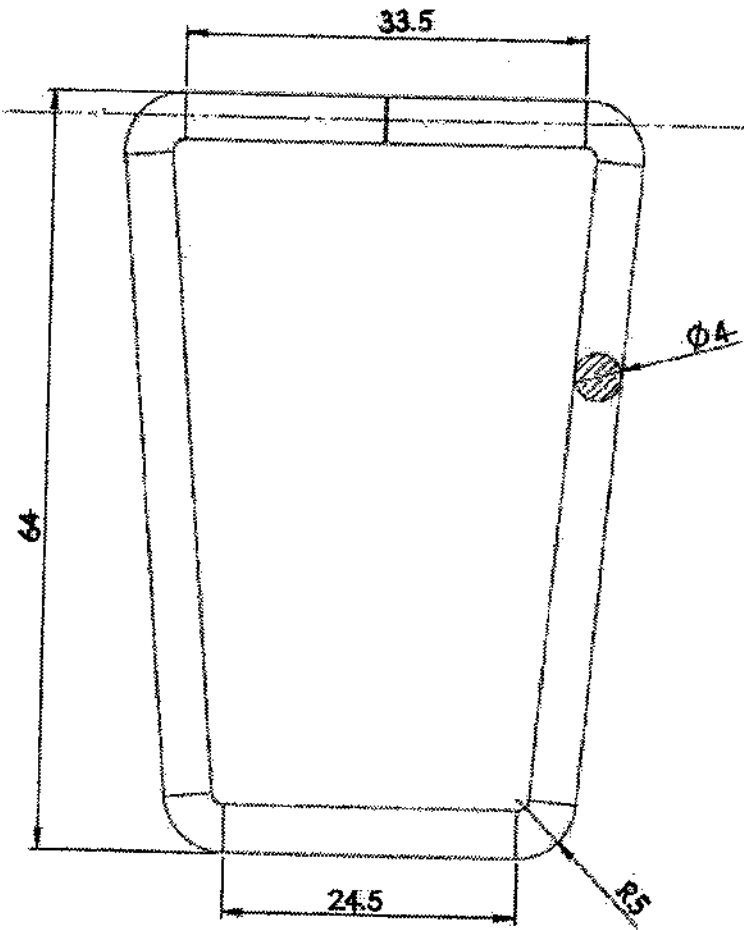



MATL: HOT ROLLED MEDIUM AND HIGH TENSILE STRUCTURAL STEEL TO IS: 2062 GRADE

PROTECTIVE FINISH:

PHOSPHATING TO SPECN IS: 3618 - 1985 TO CLASS A2.

PROVISIONAL

NOTE :- THIS DRG. IS PREPARED FROM DRG. PROVIDED BY U-VIII

ITEM NO	MATERIAL	NO.OFF	NOMENCLATURE	REMARKS
	AS STATED		 <b>आयुध निर्माणी, चांदा</b> ORDNANCE FACTORY CHANDA	HOOK LINK
	MASS: -			
				
	PREPD. BY	SIGN	DATE	
	OIC/R&D	<i>[Signature]</i>	05.10.23	
	DO/R&D	<i>[Signature]</i>	5/10	ASSLY. & STORE DRG. NO. - PACKAGING BOX FOR ROUND 125MM HE
	OIC/U-VIII	<i>[Signature]</i>	5/10	DRG. NO.: - PROPISK-845-25
	DO/U-VIII	<i>[Signature]</i>	6/10	DATE :- 05.10.23
	CO/U-VIII	<i>[Signature]</i>	-	SCALE: - 2:1
D.A. NO	DETAILS	INTL.		
	REVISIONS			



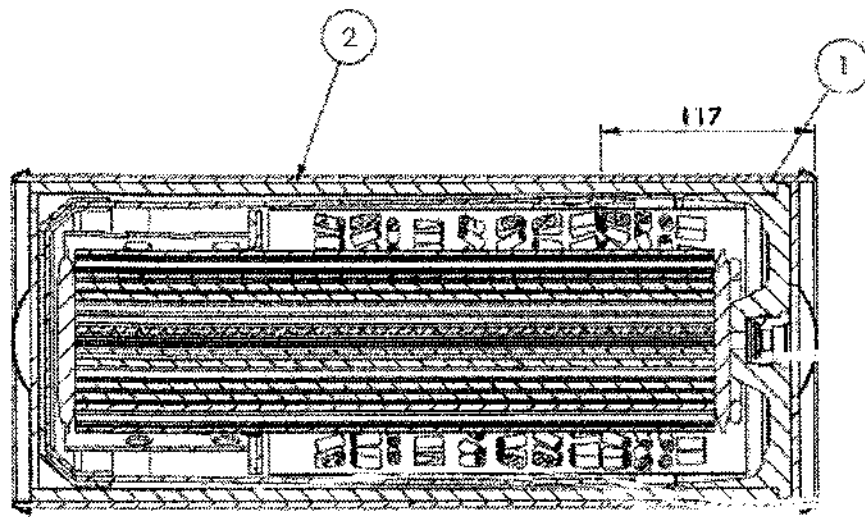
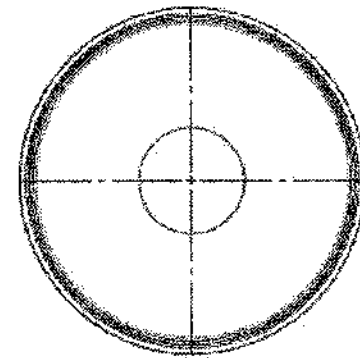
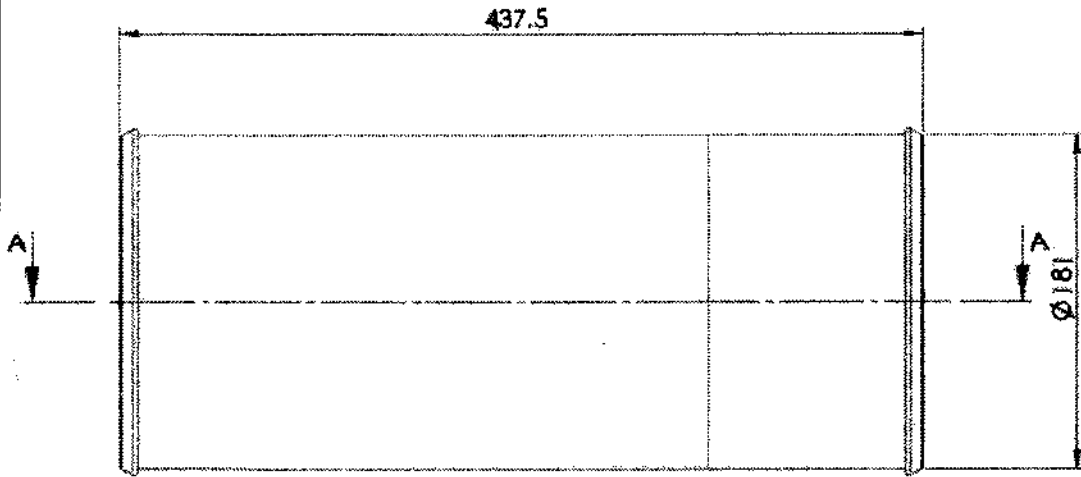

SECTION A-A  
SCALE 1:3



NOTE :- THIS DRG. IS PREPARED FROM DRG. PROVIDED BY U-VIII

PROVISIONAL

ITEM NO	MATERIAL	NO.OFF	NOMENCLATURE	REMARKS
2	-	1	SLEEVE SUB ASSY PRIMARY	
1	-	1	SLEEVE LID SUB ASSY PRIMARY	
AS STATED			ORDNANCE FACTORY CHANDA	
MASS: -			LP CONTAINER ASSY PRIMARY	
PREPD.BY		05.10.23	ASSLY.& STORE DRG. NO. -	
OIC/R&D		S/10	PACKAGING BOX FOR ROUND 125MM HE	
DO/R&D		S/10	DRG. NO.: - PROP/5K - 845 - 26	
APPROVED		S/10	DATE :- 05.10.23	
DO/U-VIII		6/10	SCALE: - 1:3	
GO/U-VIII	-	-		

PROVISIONAL

NOTES:

1. CAP END TO BE SECURED BY SPINNING CURLED EDGE INTO SLEEVE LID OUTER USING ARALDITE
2. ARALDITE TO BE APPLIED IN THE CHANNEL OF THE CAP END IMMEDIATELY AFTER SPINNING

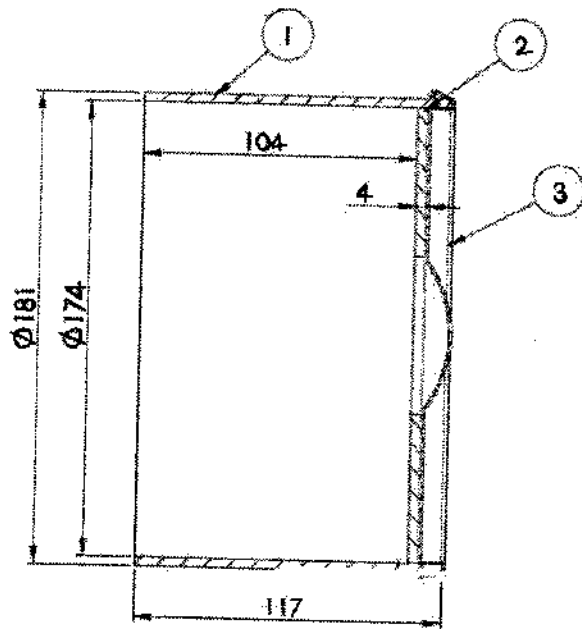

SECTION A-A  
SCALE 1:2

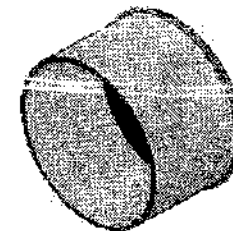
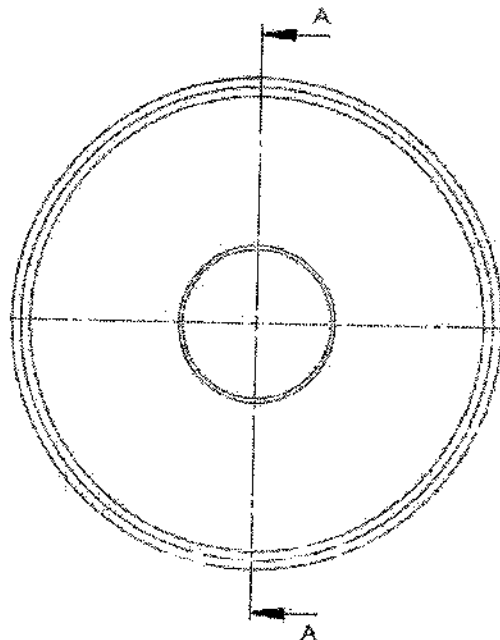

NOTE :- THIS DRG. IS PREPARED FROM DRG. PROVIDED  
By U-VIII

PROVISIONAL

3	COLLEDED PAPER	1	END CAP PRIMARY	
2	MILBOARD PAPER	1	WASHER MILBOARD_1	
1	KRAFT BOARD PAPER	1	SLEEVE LID OUTER PRIMARY	

ITEM NO	MATERIAL	NO. OFF	NOMENCLATURE	REMARKS
---------	----------	---------	--------------	---------

MASS: -

आयुध निर्माणी, चांदा  
ORDNANCE FACTORY CHANDA

SLEEVE LID SUB ASSY  
PRIMARY

PREP.D BY	SIGN	DATE	
OIC/R&D	[Signature]	05.10.23	
NO/R&D	[Signature]	5/10	ASSLY. & STORE DRG. NO. - PACKING BOX FOR ROUND 125MM HE
OIC/U-VII	[Signature]	5/10	DRG. NO.: - PROP/ISK-845-27
DO/A'-VII	[Signature]	6/10	DATE :- 05.10.23
GO/L'-VII	[Signature]	-	SCALE: - 1:2

D.A. NO	DETAILS	INTL.
	REVISIONS	

PROVISIONAL

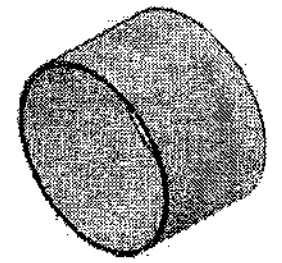
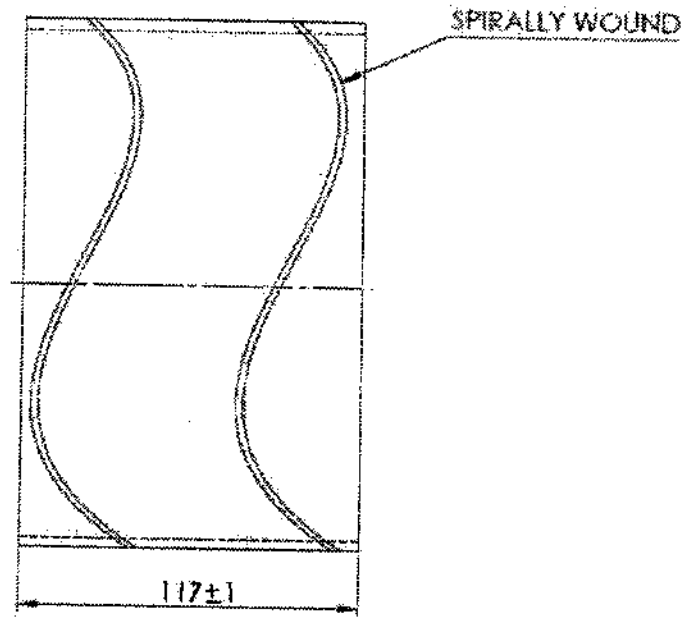
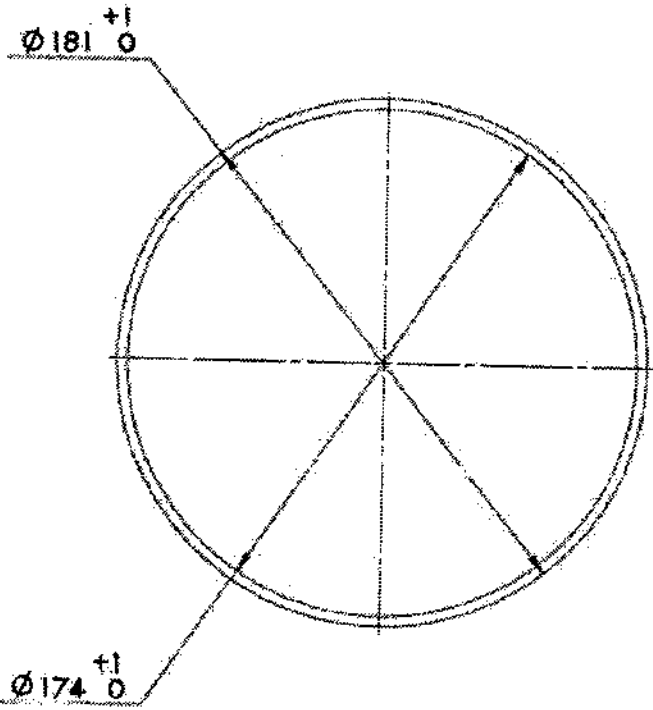

MATL - KRAFT BOARD / PAPER

PROTECTIVE NOTES :

TO BE COATED EXTERNALLY WITH TWO COATS OF POLYCRAFT PAPER.

NOTE :- THIS DRG. IS PREPARED FROM DRG. PROVIDED BY U-VIII

PROVISIONAL

ITEM NO	MATERIAL	NO.OFF	NOMENCLATURE	REMARKS
	AS STATED		आयुध निर्माणी, चांदा	
	MASS-		ORDNANCE FACTORY CHANDA	
			SLEEVE LID OUTER	
			PRIMARY	
PREP.D.BY	DATE			
OIC/R&D	5/10			ASSLY.& STORE DRG. NO.-
DO/R&D	5/10			PACKAGING BOX FOR ROUND 125MM HE
OIC/U-VII	5/10			DRG. NO.: - PROP/5K - 845 - 28
DO/U-VII	5/10			DATE :- 05.10.23
GO/U-VI				SCALE:-
D.A.NO	DETAILS	INTL.		
DATE	REVISIONS			

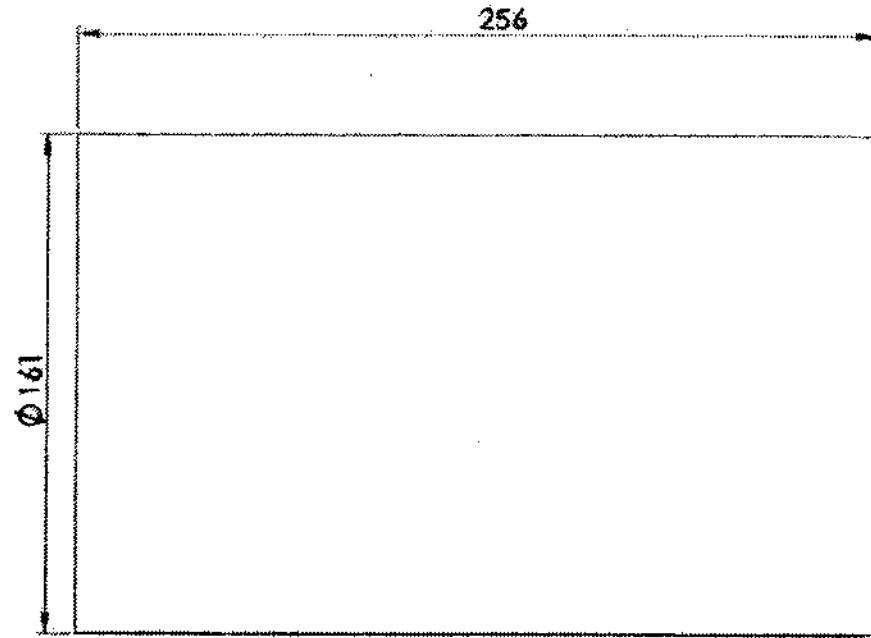
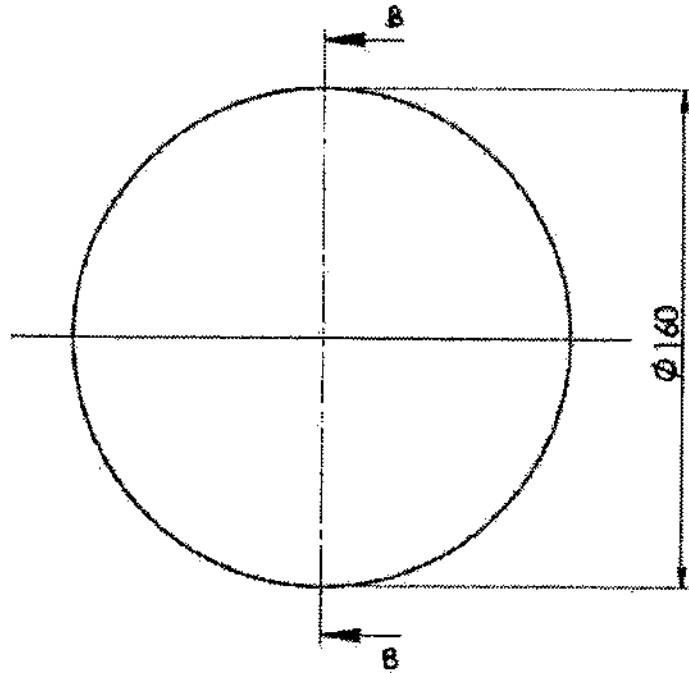

SECTION B-B  
SCALE 1:2

MATL: KRAFT PAPER / CORRUGATED SHEET

NOTE :- THIS DRG. IS PREPARED FROM DRG. PROVIDED BY U-VIII



ITEM NO.	MATERIAL	NO. OFF	NOMENCLATURE
	AS STATED		आयुध निर्माणी, चांदा ORDNANCE FACTORY CHANDA
	MASS -		
			SLEEVE INNER 2 PRIMARY
	PREP. BY	SIGN	DATE
			05.10.23
	OIC/R&D		5/10
	DO/R&D		5/10
	DIC/U-VIII		5/10
	DO/II-VII		6/10
D.A. NO.	JUL 14/23	INTL.	
DATE			
			ASSLY. & STORE DRG. NO. - PACKAGING BOX FOR ROUND 125/46 NC
			DRG. NO. :- PROP 1SK-845-23
			DATE 05.10.23
			SCALE 1:2

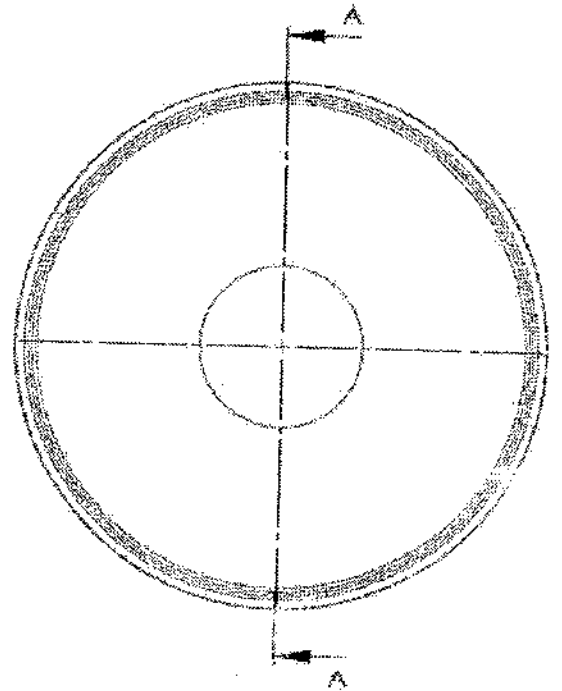
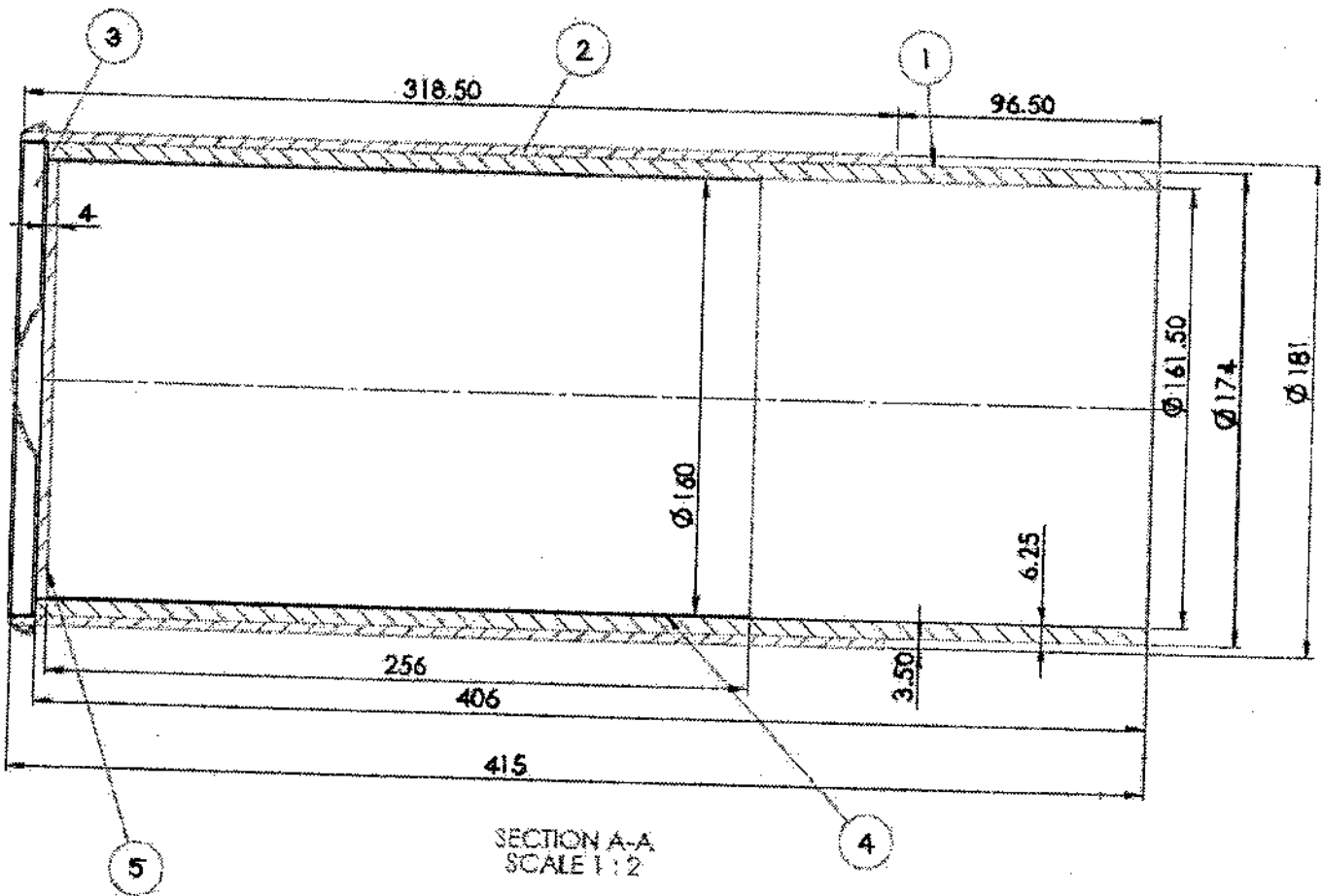

SECTION A-A  
SCALE 1:2

NOTES :-

1. CAP END TO BE SECURED BY SPINNING CURLED EDGE INTO SLEEVE LID OUTER USING ARALDITE.
2. ARALDITE TO BE APPLIED IN THE CHANNEL OF THE CAP END IMMEDIATELY AFTER SPINNING.

NOTE :- THIS DRG. IS PREPARED FROM DRG. PROVIDED  
By U- VIII

5	MILL BOARD	1	PAPER DISC PRIMARY	
4	KRAFT PAPER	1	SLEEVE INNER 2 PRIMARY	
3	COLD ROLLED LOW CARBON STEEL	1	END CAP PRIMARY	
2	KRAFT BOARD/PAPER	1	SLEEVE OUTER PRIMARY	
1	KRAFT BOARD/PAPER	1	SLEEVE INNER PRIMARY	

ITEM NO	MATERIAL AS STATED	NO.OFF	NOMENCLATURE	REMARKS
 <b>आयुध निर्माणी, चांदा</b> <b>ORDNANCE FACTORY CHANDA</b>				
<b>SLEEVE SUB ASSY</b> <b>PRIMARY</b>				
PREP.D BY	SIGN	DATE		
OIC/R&D		05.10.23		
DO/R&D		5/10	ASSLY. & STORE DRG. NO. - PACKING BOX FOR ROUND 125MM HE	
APPROVED		5/10	DRG. NO. :- PROP/ISK - 845 - 30	
OIC/U-VI		6/10	DATE : 05.10.23	
CC, E-VI			SOP :- 1-2	
GO/J-VI				

D.A. NO	DETAILS	INTL.
DATE		
REVISIONS		

PROVISIONAL

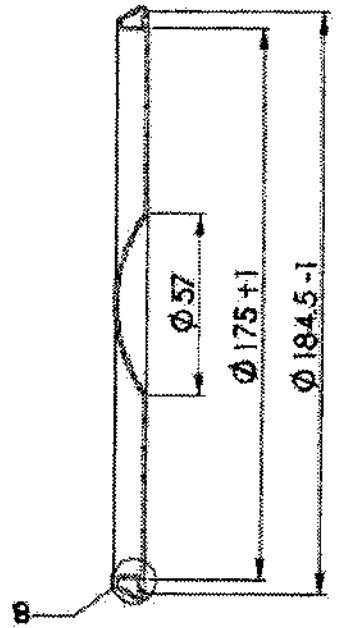
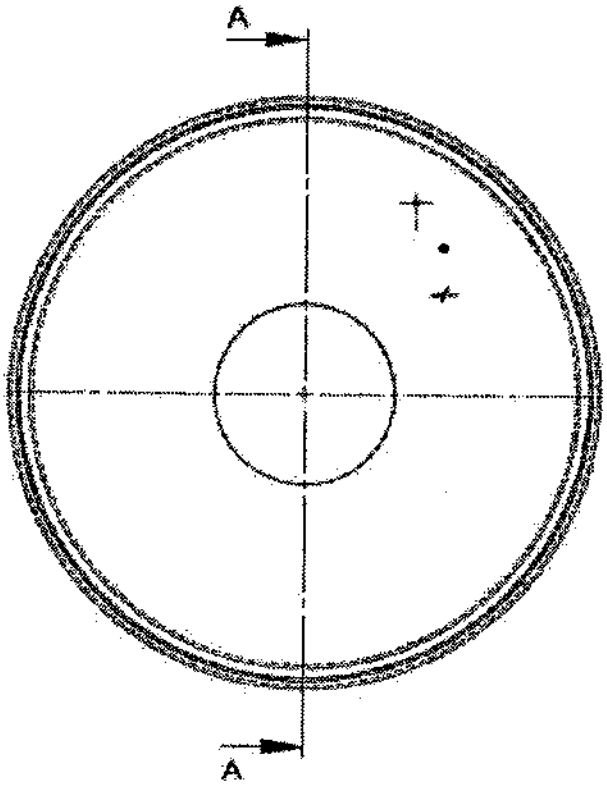

SECTION A-A

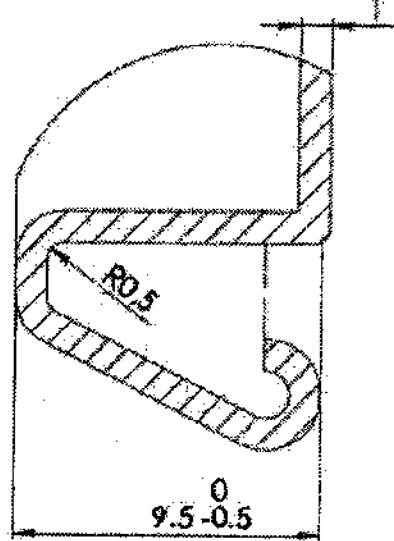

DETAIL B  
SCALE 5:1

NOTES :-

1. AFTER CLEANING AND INSPECTION, END CAP TO BE PHOSPHATED TO I A-1273 CLASS II FOLLOWED BY POLYESTER POWDER COATING OF 60-80 MICRON OF OLIVE GREEN SAND.
2. MARKING TO BE EMBOSSED/PAINTED ON FROM OUTSIDE IN 10MM TYPE CONTAINER'S INITIAL'S OR
  - + Recognised trade mark.
  - DATE OF MANUFACTURING (MONTH & YEAR)
  - + BATCH NO.
4. LOAD FOR PULL OFF TEST : 250 KG. MIN
5. EMBOSSEING/PAINTING TO BE DONE SUITABLY : FONT SIZE 20MM. AERIAL FONT COLOUR YELLOW. "125mm ESAPDS PRAC. PRIMARY CARTON"
6. SHEET THICKNESS 1.0MM.

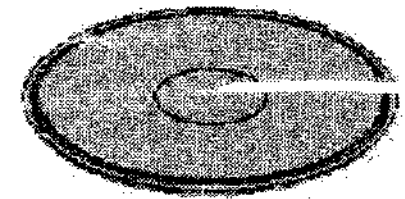

MATL. - COLD ROLLED CARBON STEEL & STRIPS  
 SPEC. TO IS : 513:1993, REAFFIRMED 2003, ANY OF GR. 01/D/D  
 NOTE :- THIS DRG. IS PREPARED FROM DRG. PROVIDED BY U-VIII

ITEM NO.	MATERIAL	NO. OFF.	NOMENCLATURE	REMARKS
	AS STAGS		आयुध निर्माणी, चांदा	
MASS:-			ORDNANCE FACTORY, CHANDIA	
			END CAP PRIMARY	
PREP. BY	SIGN	DATE		
OIC/R&D		05.10.23		
DO/R&D		5/10		
		5/10		
		6/10		
O.A. NO.	DETAILS	INTL.		
DATE				
	REVISIONS			

ASSLY. & STORE DRG. NO. -  
 PACKAGING BOX FOR ROUND 125MM HE  
 DRG. NO. :- PROP/SK - 845 - 31

DATE :- 05.10.23

SCALE 5:1









