

M 6009

NOTES:

1. FINISH $\sqrt{3.2}$ ALL OVER.
2. BREAK EDGES 0.076 + 0.305 UNLESS OTHERWISE SPECIFIED.
3. MATERIAL: STEEL, ASTM A331 OR A322; 4140, 4150, OR SPEC MIL-S-22141, IC-4140.
4. HEAT TREATMENT: HEAT AT 838° TO 860° C. OIL QUENCH. TEMPER FOR 1 HOUR MIN TO RH C38-46.
5. FINAL PROTECTIVE FINISH: FINISH 5.31.2 OR 5.32.2 OF MIL-STD-171.
6. MIL-STD-2175 CLASS 2, GRADE B, SHALL BE APPLICABLE FOR THE INSPECTION OF INVESTMENT CASTINGS.
7. ASME Y14.5M-1994 APPLIES.
8. DIMENSIONS MARKED * ARE LOCATED FROM 4.775 DIA. HOLE.
9. INSCRIBE PART NUMBER 6008949 AND MANUFACTURER'S CAGE CODE '1V2A7' 1.574 ± 0.254 HIGH X 0.127 ± 0.381 DEEP PER MIL-STD-130.

REVISIONS				
ZONE	REV.	DESCRIPTION	DATE	APPROVED
	B	ADDED TOL. TO TITLE BLOCK, ADDED HARDNESS SPEC TO NOTE 4	6/26/2017	DAS
	C	ADDED SHEET 2 + ALTERNATE SERRATION CONFIGURATION	5/25/2018	G. HERSHBERGER
	D	UPDATED DRAWING NOTES AND VIEWS	6/7/2018	T. HARDMAN

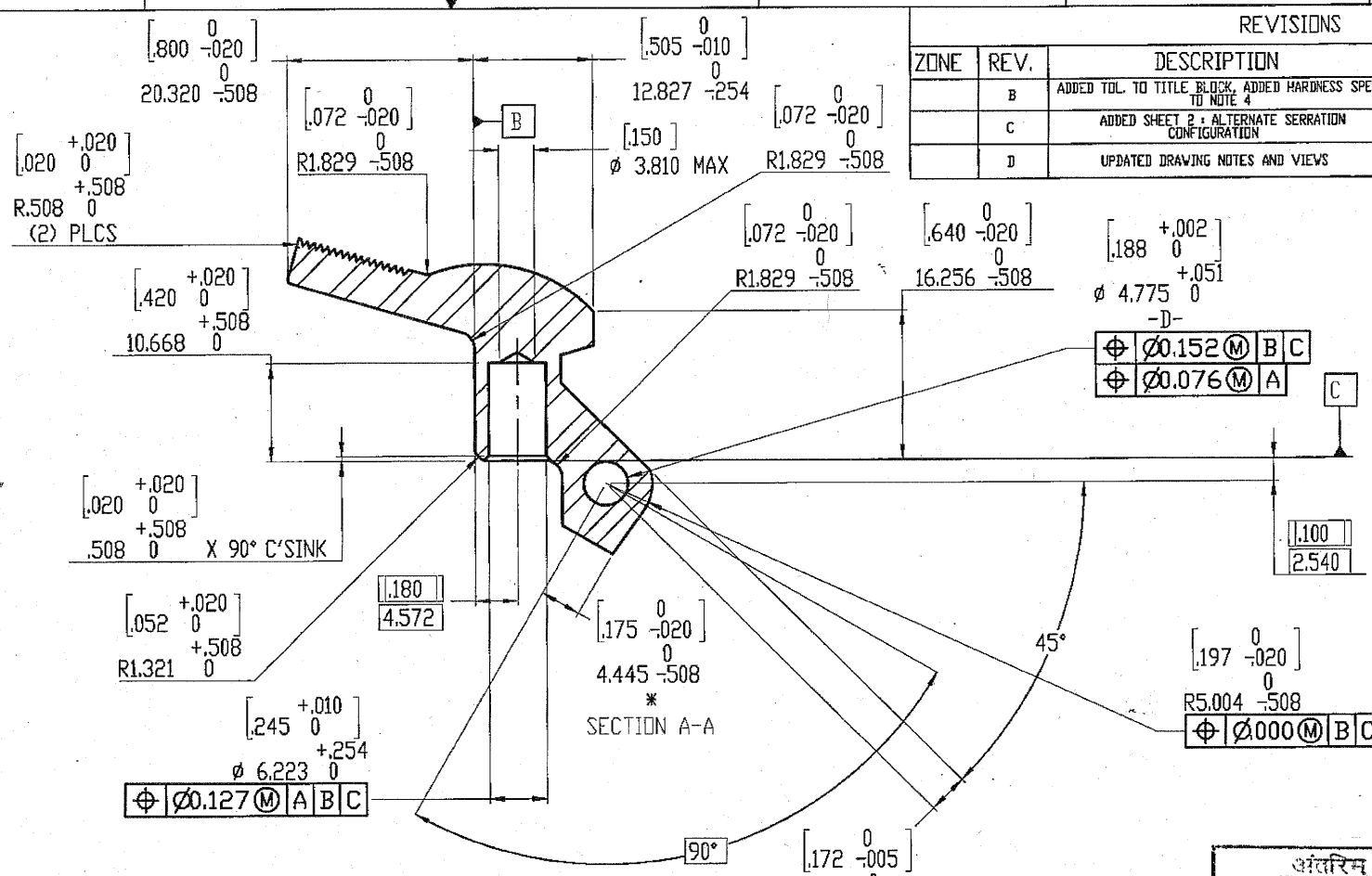

\varnothing 0.152 M B C
\varnothing 0.076 M A

\varnothing 0.000 M B C

\varnothing 0.127 M A B C

UN CONTROLLED COPY
 CERTIFIED CORRECT COPY OF APPROVED
 DRAWINGS AT THIS DATE. 29-08-2021
 DESIGN & DRAWING OFFICE.
 ORDNANCE FACTORY, TIRUCHIRAPPALI - 620 016.

अंतरिम रूप से प्रमाणित
 Provisionally Approved
 24 AUG 2021
 दिनांक
 हस्ताक्षर/Sig
 foo (male (AP))

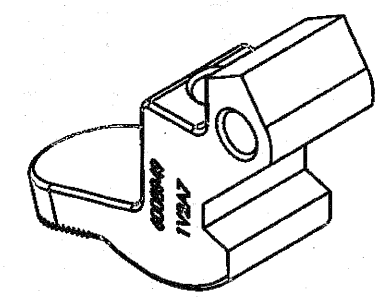
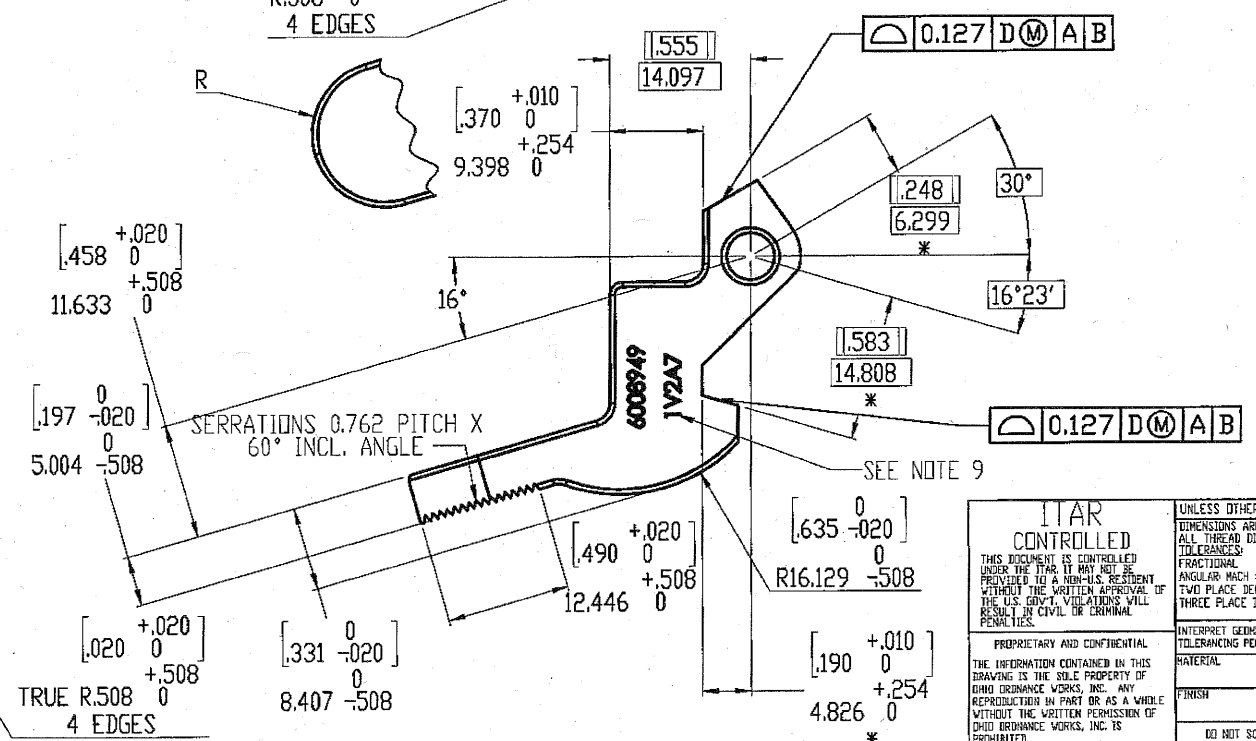
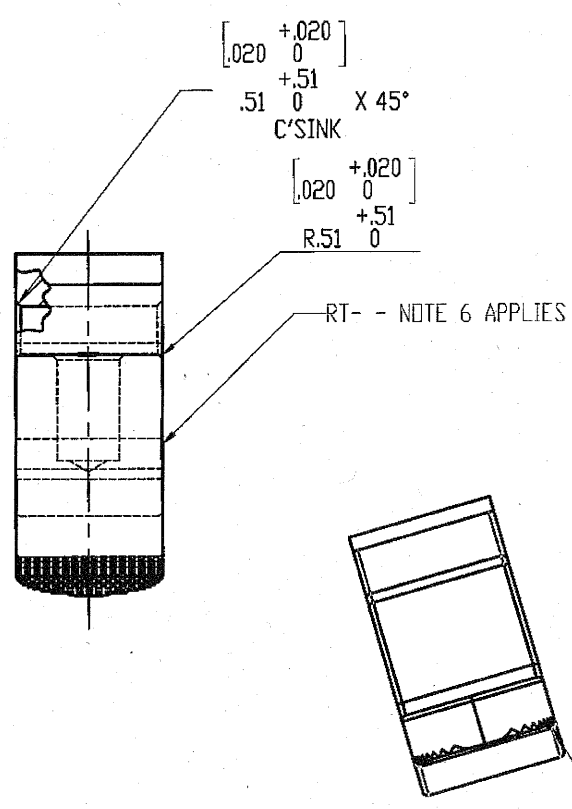
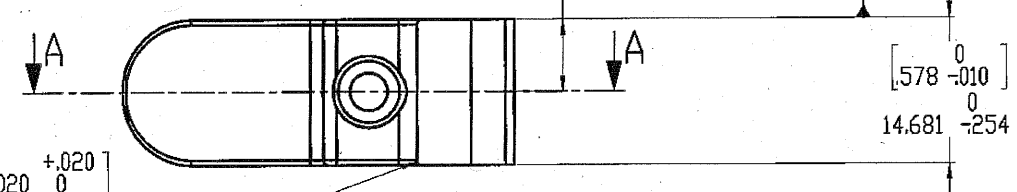

ITAR CONTROLLED THIS DOCUMENT IS CONTROLLED UNDER THE ITAR. IT MAY NOT BE PROVIDED TO A NON-US RESIDENT WITHOUT THE WRITTEN APPROVAL OF THE U.S. GOVERNMENT. VIOLATORS WILL BE SUBJECT TO CIVIL OR CRIMINAL PENALTIES. PROPRIETARY AND CONFIDENTIAL. THE INFORMATION CONTAINED IN THIS DRAWING IS THE SOLE PROPERTY OF OHIO ORDNANCE WORKS, INC. ANY REPRODUCTION IN PART OR AS A WHOLE WITHOUT THE WRITTEN PERMISSION OF OHIO ORDNANCE WORKS, INC. IS PROHIBITED.	UNLESS OTHERWISE SPECIFIED: DIMENSIONS ARE IN INCHES. ALL THREAD DIA. ARE IN INCHES. TOLERANCES: FRACTIONAL ANGULAR MACH 41° BEND TWO PLACE DECIMAL ± THREE PLACE DECIMAL ±	NAME	DATE	OHIO ORDNANCE WORKS, INC. LATCH, BACK PLATE, 00W50BMG SIZE C 6008949 REV D SCALE: 2:1 WEIGHT: SHEET 1 OF 2	
	INTERPRET GEOMETRIC TOLERANCING PER: MATERIAL FINISH	DRAWN	PHD		08/07/14
	DO NOT SCALE DRAWING	CHECKED			
		ENG APPR.			

NOTES :

1. THIS SERRATION AND PROFILE CONFIGURATION IS AN ALTERNATE DESIGN THAT CAN BE WIRE EDM'D.

REVISIONS				
ZONE	REV.	DESCRIPTION	DATE	APPROVED
-	-	See Sheet1	-	-

M-6009

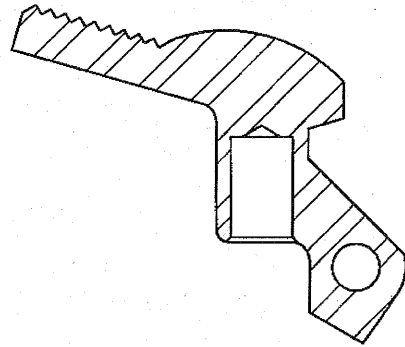

SECTION E-E

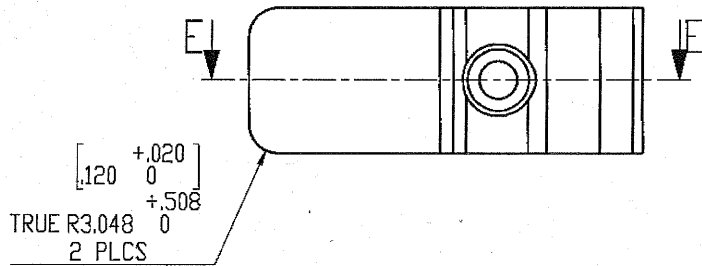
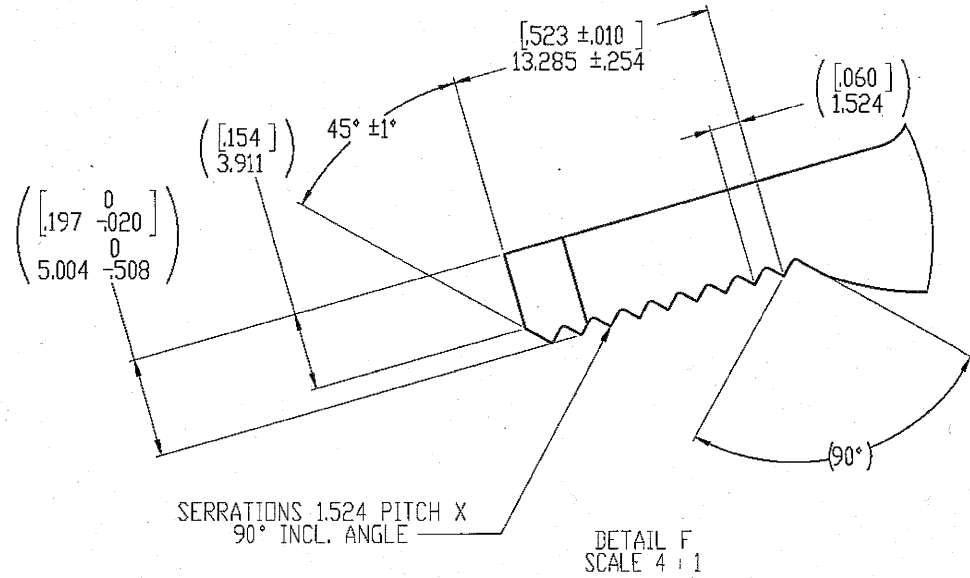

[0.010 ± 0.002]
R.254 ± 0.051
9 PLCS

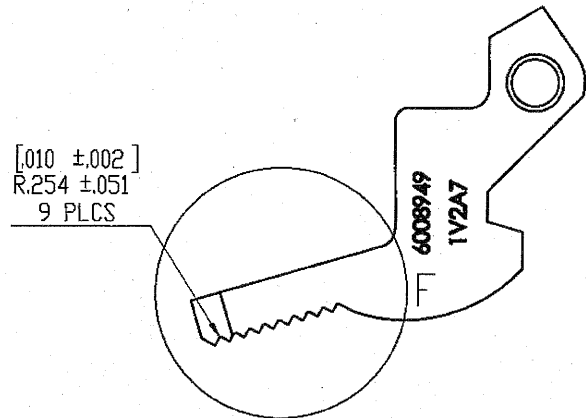

UN CONTROLLED COPY
CERTIFIED CORRECT COPY OF APPROVED
DRAWINGS AT THIS DATE. 28.08.2021
DESIGN & DRAWING OFFICE,
ORDNANCE FACTORY, TIRUCHIRAPPALI -620 016.

अनियंत्रित रूप से प्रमाणित
Provisionally Approved
24 AUG 2021
दिनांक
हस्ताक्षर/Sig
for model

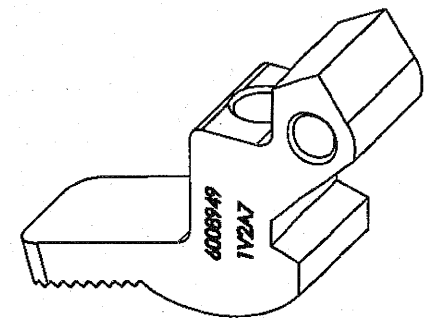

ITAR CONTROLLED THIS DOCUMENT IS CONTROLLED UNDER THE ITAR. IT MAY NOT BE PROVIDED TO A NON-U.S. RESIDENT WITHOUT THE WRITTEN APPROVAL OF THE U.S. GOV'T. VIOLATIONS WILL RESULT IN CIVIL OR CRIMINAL PENALTIES. PROPRIETARY AND CONFIDENTIAL THE INFORMATION CONTAINED IN THIS DRAWING IS THE SOLE PROPERTY OF OHIO ORDNANCE WORKS, INC. ANY REPRODUCTION IN PART OR AS A WHOLE WITHOUT THE WRITTEN PERMISSION OF OHIO ORDNANCE WORKS, INC. IS PROHIBITED.	UNLESS OTHERWISE SPECIFIED DIMENSIONS ARE IN MM/INCHES ALL THREAD DIM ARE IN INCHES	DRAWN	NAME	DATE	OHIO ORDNANCE WORKS, INC. LATCH, BACK PLATE, DDW50BMG SIZE C 6008949 REV D SCALE: 2:1 WEIGHT: SHEET 2 OF 2
	FRACTIONS: ANGULAR WITH 45° BEND TWO PLACE DECIMAL ± THREE PLACE DECIMAL ±	CHECKED			
	INTERPRET GEOMETRIC TOLERANCING PER MATERIAL FINISH	ENG APPR.			
	DO NOT SCALE DRAWING	MFG APPR.			
	COMMENTS:	QA			