

Б-Б (1:1) ○

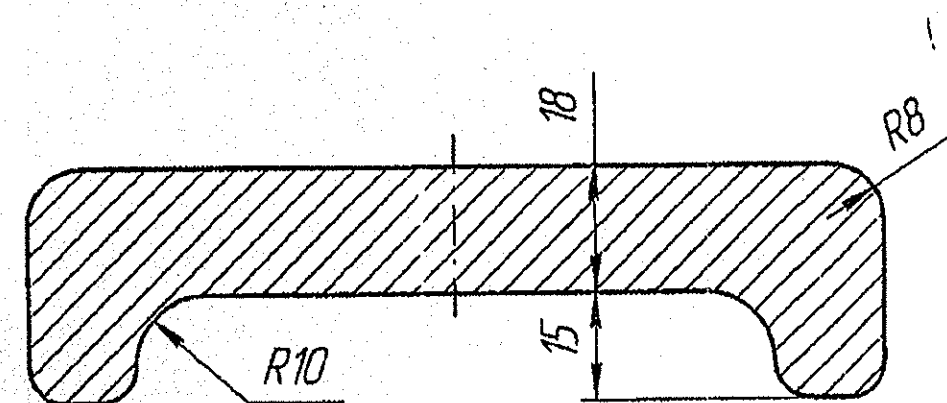

А-А ○

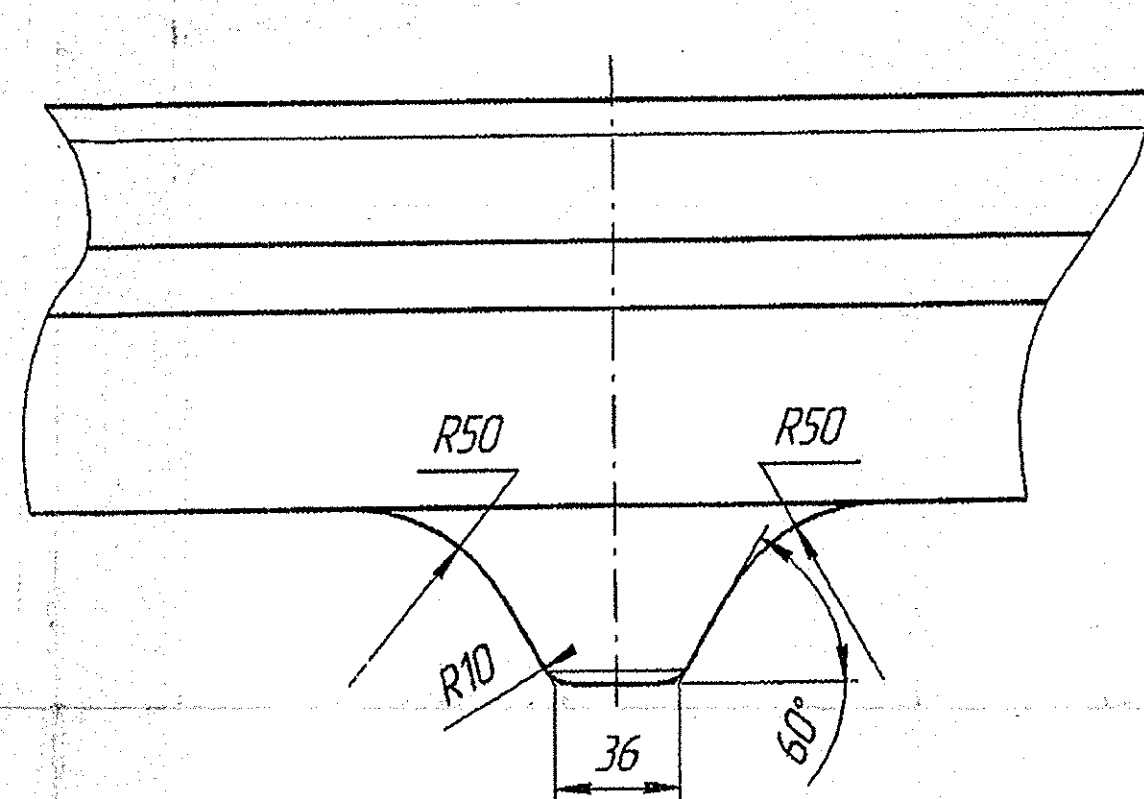

Х-Х (1:1) ○

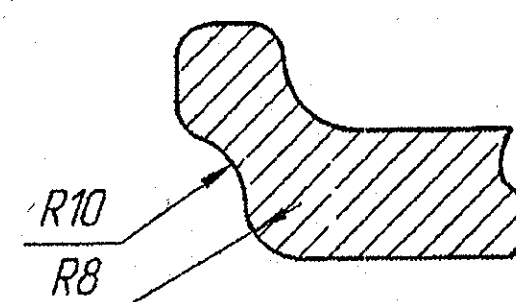

1. STEEL GRADE HEAT TREATMENT METHOD ACCEPTANCE AND TESTING AS PER LIST FOR ARTICLE FROM SPECIAL STEEL HARDNESS MEDIUM HARDNESS.
2. REQUIREMENTS FOR CASTING IN MATCHING WITH 172TY5.
3. ACCURACY OF CASTING AS PER 11-0-0-10 GOST 26645-85.
4. EXTERNAL DRAFTS ANGLE UP TO 1:20.
5. UNSPECIFIED RADII 5MM.
6. BASE SURFACE SHOULD BE DRESSED.
7. UNEVENNESS CUT RAISER <sup>+5</sup> MM.
8. TO BE STAMPED STEEL GRADE HEAT NUMBER DRAWING NUMBER OF COMPONENTS.
9. DIMENSIONS FOR REFERENCE
10. WEIGHT 61.3 KG.
11. SCALE 1:2.

Approved

JGM/RG

13/12

TRIPPLICATE T-90S.

T 90

MATERIAL	CASTING WT.	
11-0-0-10 GOST 26645-85	61.3 KG	
ALT. MATERIAL	HAMMER	SCALE
		1:2
DRAWN	CHECKED	APPROVED

DRAWING NO. 172-56-009-Б/С  
NOMENCLATURE: INNER DISC

HEAVY VEHICLES FACTORY  
AVADI, CHENNAI

RC