

IS 1593 : 1982
(Reaffirmed 2004)

(Reaffirmed 2014)

Indian Standard
SPECIFICATION FOR FUEL OILS
(Second Revision)

Sixth Reprint JANUARY 2005
(Including Amendment No. 1 and 2)

UDC 665.754

© *Copyright* 1983

BUREAU OF INDIAN STANDARDS
MANAK BHAVAN, 9 BAHADUR SHAH ZAFAR MARG
NEW DELHI 110002

Gr 4

January 1983

**AMENDMENT NO. 1 DECEMBER 1988
TO
IS : 1593 - 1982 SPECIFICATION FOR
FUEL OILS**

(Second Revision)

[Page 5, Table 1, Sl No. (vi), col 1 to 6] — Substitute the following for the existing item:

Sl No.	CHARACTERISTIC	REQUIREMENT FOR			
		Grade <i>LV</i> (3)	Grade <i>MV₁</i> (4)	Grade <i>MV₂</i> (5)	Grade <i>MV</i> (6)
(1) vi)	(2) Kinematic viscosity in centi- stokes at 50°C, <i>Max</i> : Above Up to	— 80, <i>Max</i>	80 125	125 180	180 370

(PCDC 3)

**AMENDMENT NO. 2 NOVEMBER 1993
TO
IS 1593 : 1982 SPECIFICATION FOR FUEL OILS
(*Second Revision*)**

[*Page 5, Table 1, Sl No. (iv), col 7*] — Read as follows in place of the existing:

'P : 16 or P : 32'

(PCD 3)

Printed at New India Printing Press, Khurja, India

Indian Standard

SPECIFICATION FOR FUEL OILS

(Second Revision)

Petroleum Products Sectional Committee, PCDC 3

<i>Chairman</i>	<i>Representing</i>
DR I. B. GULATI	Indian Institute of Petroleum (CSIR), Dehradun
<i>Members</i>	
SHRI H. K. MULCHANDANI (Alternate to Dr I. B. Gulati)	
SHRI S. K. BASU	Directorate General of Technical Development, New Delhi
SHRI P. S. R. MURTHY (Alternate)	
DR K. S. BHATTACHARYA	Ministry of Defence (DGI)
SHRI J. P. SHUKLA (Alternate)	
SHRI P. R. CHANDRASEKHAR	Director General of Civil Aviation, New Delhi
SMT N. V. ASNANI (Alternate)	
SHRI CHARANJIT LAL	Chief Controller of Explosives, Nagpur
SHRI B. R. DAVE (Alternate)	
DEPUTY DIRECTOR (CHEM)	National Test House, Calcutta
DEPUTY DIRECTOR (STANDARDS)	Railway Board (Ministry of Railways)
ASSISTANT RESEARCH OFFICER (CHEM) (Alternate)	
BRIG LOKESH DHAR	Central Institute of Road Transport (Training & Research), Pune
SHRI B. K. CHAPRA (Alternate)	
DIRECTOR (MARINE)	Naval Headquarters, New Delhi
LT GEORGE MATHEW (Alternate)	
SHRI M. S. EKBOTE	Indian Airlines, New Delhi
DR G. K. AGARWAL (Alternate)	
SHRI P. K. GOEL	Indian Oil Corporation Ltd (R & D Centre), Faridabad
DR G. J. RAO (Alternate)	
SHRI G. C. GOSWAMI	Indian Oil Corporation Ltd (Assam Oil Division), Digboi
SHRI I. CHANDRA (Alternate)	
DR G. JAYARAMA RAO	Ministry of Petroleum, Chemicals and Fertilizers, New Delhi
SHRI T. P. SUBRAHMANYAM (Alternate)	
SHRI KESHAV PRABAD	Ministry of Finance (Department of Revenue)
SHRI S. KRISHNAMURTHY (Alternate)	

(Continued on page 2)

© Copyright 1983

BUREAU OF INDIAN STANDARDS

This publication is protected under the *Indian Copyright Act* (XIV of 1957) and reproduction in whole or in part by any means except with written permission of the publisher shall be deemed to be an infringement of copyright under the said Act.

IS : 1593 - 1982

(Continued from page 1)

<i>Members</i>	<i>Representing</i>
SHRI V. LOBO	Oil Coordination Committee, New Delhi
SHRI S. N. MATHUR (Alternate)	
SHRI MANUEL KARNA	Cochin Refineries Ltd, Cochin
SHRI S. R. MEHTA	Hindustan Petroleum Corporation Ltd, Bombay
SHRI P. M. RAO (Alternate)	
SHRI I. M. MERCHANT	Bharat Petroleum Corporation Ltd, Bombay
SHRI K. R. RAO (Alternate)	
SHRI D. K. MUKHERJEE	Central Fuel Research Institute (CSIR), Dhanbad
SHRI V. A. KRISHNAMURTHY (Alternate)	
SHRI P. S. NAGASUNDARAM	Directorate of Technical Development & Production (Air) (Ministry of Defence)
SHRI Y. R. MAHAJAN (Alternate)	
SHRI K. S. C. NAIR	Indian Oil Corporation Ltd (Marketing Division), Bombay
SHRI A. JANAKIRAMAN (Alternate)	
SHRI K. U. RAO	Hindustan Petroleum Corporation Ltd, Vishakhapatnam
SHRI P. V. MORE (Alternate)	
SHRI R. A. RAO	Lubrizol India Ltd, Bombay
DR K. L. MALLIK (Alternate)	
COL P. N. SAWHNEY	Directorate of Supplies and Transport, Army Head- quarters (Ministry of Defence)
LT-COL MADAN LAL (Alternate)	
SHRI B. M. SHARMA	Aeronautical Development Establishment (Ministry of Defence)
DR R. D. SRIVASTAVA	Ministry of Defence (R & D)
DR P. S. VENKATARAMANI (Alternate)	
SHRI T. V. VARGHESE	Madras Refineries Ltd, Madras
SHRI P. BHASKARA MENON (Alternate)	
SHRI J. L. VASUDEVA	Indian Oil Corporation Ltd (Refineries & Pipelines Division), New Delhi
WO CDR S. N. WADHWA	Air Headquarters (Ministry of Defence)
SON LDR P. J. LOUIS (Alternate)	
SHRI M. S. SAXENA, Director (P & C)	Director General, ISI (<i>Ex-officio-Member</i>)

Secretary

SHRI M. A. U. KIAN
Deputy Director (P & C), ISI

Furnace Oil. (Including Bunker Oil) Subcommittee, PCDC 3 : 5

<i>Convener</i>	
SHRI B. I. MEHTA	Century Shipping, Bombay
<i>Members</i>	
SHRI D. P. AHLUWALIA	Indian Oil Corporation Ltd (Refineries & Pipeline Division), New Delhi
SHRI A. K. ARORA (Alternate)	
SHRI G. BALAKRISHNAN	Bharat Petroleum Corporation Ltd, Bombay
SHRI I. M. MERCHANT (Alternate)	

(Continued on page 16)

Indian Standard

SPECIFICATION FOR FUEL OILS

(Second Revision)

0. FOREWORD

0.1 This Indian Standard (Second Revision) was adopted by the Indian Standards Institution on 14 June 1982, after the draft finalized by the Petroleum Products Sectional Committee had been approved by the Petroleum, Coal and Related Products Division Council.

0.2 This standard was originally issued in 1960 and first revised in 1971. In the revised version the requirements for pour point was incorporated as optional requirements as agreed to between the purchaser and the supplier. The details of thermal stability test for LV and MV grades for naval use was also included. The compatibility test for naval use was deleted in view of the difficulties faced in the procurement of referee fuels. This second revision is being prepared after the review of the standard in light of the present day requirements of the fuel oils for various end-uses. In this revision another intermediate grade between MV and HV has been introduced to meet the needs of the consumers / suppliers. An additional test for relative density has also been incorporated to satisfy the consumers requirements.

0.3 This standard contains clause 3.2 which calls for an agreement between the purchaser and the supplier.

0.4 For the purpose of deciding whether a particular requirement of this standard is complied with, the final value, observed or calculated, expressing the result of a test or analysis, shall be rounded off in accordance with IS : 2-1960*. The number of significant places retained in the rounded off value should be the same as that of the specified value in this standard.

1. SCOPE

1.1 This standard prescribes the requirements and the methods of **sampling** and test for fuel oils, essentially residual in character, for industrial and marine uses. These fuel oils are primarily intended for oil fired furnaces. The low viscosity grade oil is suitable for use as diluent for creosote.

* Rules for rounding off numerical values (*revised*).

IS : 1593 - 1982

2. GRADES

2.1 There shall be following four grades of the material:

- i) Grade LV Low viscosity,
- ii) Grade MV1 Medium viscosity,
- iii) Grade MV2 Medium viscosity, and
- iv) Grade HV High viscosity.

3. REQUIREMENTS

3.1 General — The material shall be hydrocarbon oils derived from petroleum or shale. This, however, shall not preclude the incorporation of small amounts of additives of hydrocarbon or non-hydrocarbon origin intended to improve ignition, combustion or other characteristics.

3.1.1 The material shall be free from grit and other foreign impurities.

3.2 Pour Point — The requirement for the pour point of the material, when tested according to IS : 1448 (P : 10)-1970*, shall be as agreed to between the purchaser and the supplier.

3.3 The material shall also comply with the requirements prescribed in Table 1, when tested according to the appropriate methods prescribed under 'P' series of IS : 1448†. Reference to the relevant test method (P :) is given in col 7 of Table 1.

4. SPECIAL REQUIREMENTS FOR NAVAL USE

4.1 In addition to those given in 3, the material required for naval purposes shall also comply with the requirements given in 4.1.1 and 4.1.2.

4.1.1 Thermal Stability for Grade LV and Grades MV1 and MV2 — The material shall pass the test prescribed in Appendix A.

4.1.2 Explosiveness Test — The material of all grades shall pass the test prescribed in Appendix B.

5. PACKING AND MARKING

5.1 Packing — The material shall be packed in suitable containers as agreed to between the purchaser and the supplier, and subject to the provisions of *Red Tariff No. 18 rules and rates for the conveyance by rail of explosives and other dangerous goods*, issued by the Indian Railways Conference Association, with any alterations made thereafter.

*Methods of test for petroleum and its products (P : 10) Pour point (*first revision*).

†Methods of test for petroleum and its products.

TABLE 1 REQUIREMENTS FOR FUEL OILS

(Clause 3.3)

Sl. No.	CHARACTERISTIC	REQUIREMENT FOR				METHOD OF TEST [REF TO (P :) OF IS : 1448*]
		Grade LV	Grade MV1	Grade MV2	Grade HV	
(1)	(2)	(3)	(4)	(5)	(6)	(7)
i)	Acidity, inorganic	Nil	Nil	Nil	Nil	P : 2
ii)	Ash, percent by mass, <i>Max</i>	0.1	0.1	0.1	0.1	P : 4 (Method A)
iii)	Gross, calorific value	Not limited, but to be reported (See Note 1)				P : 6 (for reference) and P : 7 (for routine)
iv)	Relative density at 15/15°C	Not limited, but to be reported (See Note 2)				P : 32
v)	Flash point, [Pensky martens (closed)], <i>Min</i>	66°C	66°C	66°C	66°C	P : 21
vi)	Kinematic viscosity in centistokes at 50°C, <i>Max</i>	80	125	180	370	P : 25
vii)	Sediment, percent by mass, <i>Max</i>	0.25	0.25	0.25	0.25	P : 30
viii)	Sulphur, total, percent by mass, <i>Max</i> (See Note 3)	3.5	4.0	4.0	4.5	P : 33 (for reference) and P : 35 (for routine)
ix)	Water content, percent by volume, <i>Max</i>	1.0	1.0	1.0	1.0	P : 40

NOTE 1 — Normally the gross calorific value is of the order of 10 000 cal/g.

NOTE 2 — Fuel oil for marine uses in diesel engines shall not exceed a limit of 0.99.

NOTE 3 — Recognizing the necessity for low-sulphur fuel oils in some specialized uses, a lower limit may be specified by mutual agreement between the purchaser and the supplier.

*Methods of test for petroleum and its products.

5.2 Marking

5.2.1 The material shall be supplied in accordance with the marking and delivery instructions given by the purchaser.

5.2.2 Each container shall be marked with the following information:

- a) Name and grade of the material;
- b) Manufacturers' name, initials or trade-mark;
- c) Volume of the contents in litres; and
- d) Year of manufacture or packing.

IS : 1593 - 1982

5.2.3 Each container may also be marked with the **Standard Mark**.

5.2.4 The use of the Standard Mark is governed by the provisions of Bureau of Indian Standards Act, 1986 and the Rules and Regulations made thereunder. The details of conditions under which the licence for the use of Standard Mark may be granted to manufacturers or producers may be obtained from the Bureau of Indian Standards.

6. SAMPLING

6.1 Representative samples of the material shall be drawn as prescribed in IS : 1447-1966*.

6.2 All the requirements given in this specification shall be tested on the composite sample.

6.3 The lot shall be declared as conforming to the requirements of this specification if all the test results on the composite sample meet the corresponding specification requirements.

APPENDIX A

(Clause 4.1.1)

TEST FOR THERMAL STABILITY

(Adapted from ASTM Standard No. D 1661/64)

A-1. SCOPE

A-1.1 This method of test prescribes a procedure for determining the preheater fouling characteristics of fuel oils.

A-2. OUTLINE OF METHODS

A-2.1 The fuel sample, circulated by thermosiphon action through a glass apparatus, is in contact for 6 hours with the surface of a steel thimble containing a sheathed heating element. The sample is heated on the hot surface of the steel thimble in a heater chamber, flows upward through a riser tube, then descends in a connecting tube and returns to the heater chamber for recirculation. The temperature between the sheathed heating element and the thimble in the heater chamber is maintained at 175°C. At the end of the test period, the thimble is removed and examined for sediment formation and discolouration on the surface.

A-3. APPARATUS

A-3.1 Heater Unit— Made of heat resistant glass and of the form, dimensions and tolerances as shown in Fig. 1, the lower part of which,

*Methods of sampling of petroleum and its products.

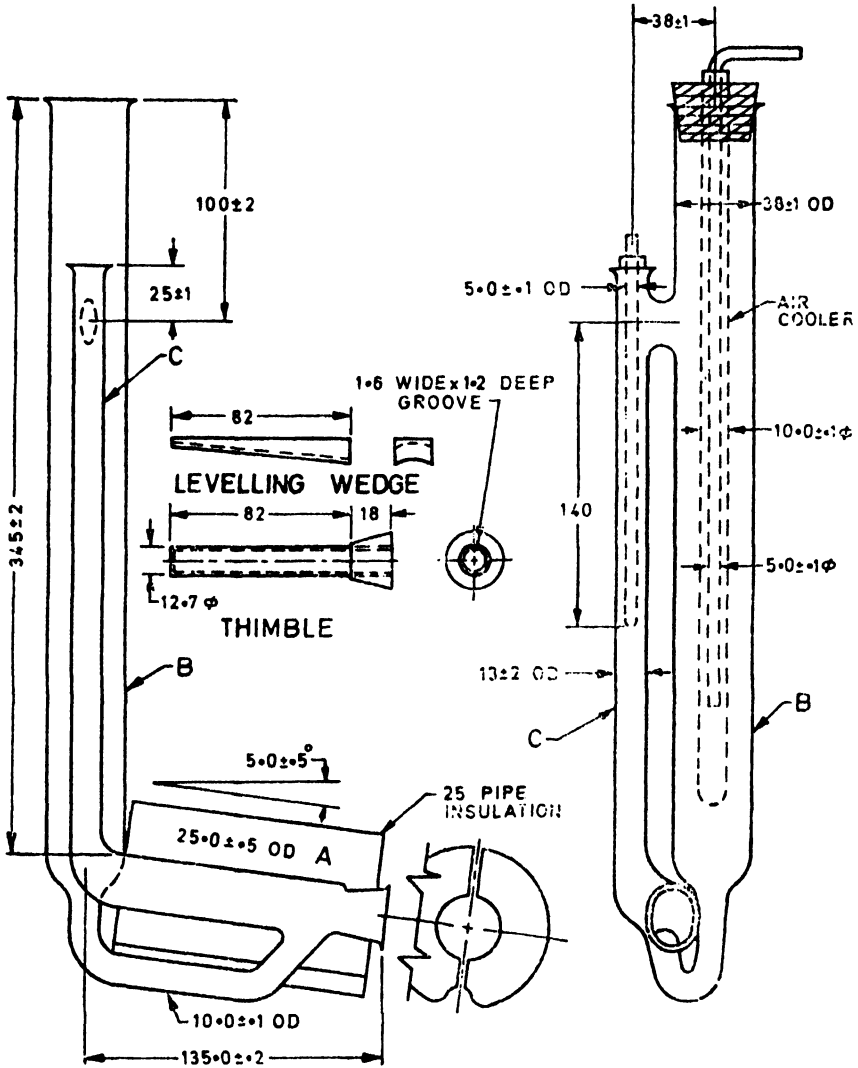

All dimensions in millimetres.

FIG. 1 THERMAL STABILITY HEATER UNIT

IS : 1593 - 1982

designated as *A*, is tilted at an angle of 5.0 ± 0.5 degree to aid the circulation of the oil. A finger air cooler consisting of a heat-resistant glass tube sealed at one end, about 330 mm long and 10 mm OD, into which is placed a glass tube of 5 mm OD, is equipped with a notched stopper and inserted in tube *B*. The 5 mm OD tube is bent downward near the top so that flexible tubing may be attached and air blown into the cooler.

A-3.2 Metal Thimble — 100 mm of round seamless mild carbon-steel tubing, 12.7 mm in OD and 1.6 mm in wall thickness is reamed to a snug fit for the heater cartridge and sealed at one end. A groove 1.6 mm wide and 1.2 mm deep to hold 0.315 mm thermocouple wire is cut into the length of the inner wall.

A-3.3 Heating Element — 115 V, 75 W, 60 mm long and 9.5 mm in diameter.

A-3.4 Variable Voltage Source — Variable transformer or rheostat of suitable rating connected to 220 to 240 V ac supply.

A-3.5 Insulation — 115 mm length of 25 mm diameter pipe insulation cut and fitted to cover tube *A*. A suitable clamp shall be used to hold the insulation in position.

A-3.6 Temperature Measuring Devices — For measuring thimble temperature and oil temperatures in tubes *B* and *C*, suitable thermocouples with temperature indicators shall be used (*see also* Note under A-3.6.3). Temperatures shall be measured at the points detailed below utilizing a multiple switch.

A-3.6.1 Thimble Temperature — With thermocouple junction between the heating element and the metal thimble at a point on the top and 38 mm from the closed end of the thimble.

A-3.6.2 Oil Temperature Entering Heating Chamber — With thermocouple junction at a point 25 mm below the bottom of the air cooler and centred in tube *B*.

A-3.6.3 Oil Temperature Leaving Heating Chamber — With thermocouple junction at the bottom of a 5-mm OD glass air-well located 140 mm below the centre of the short arm connecting tubes *B* and *C*.

NOTE — For measuring the oil temperature leaving the heating chamber, a thermometer* conforming to following requirements may be used:

Range, °C	30 to 300
Graduation, °C	0.5
Immersion	Total
Overall length, mm	400
Stem diameter, mm	6.0 to 7.0
Bulb length, mm	9.0 to 14.0

*Thermometers with the ASTM designation 16 C of E¹ conform to these requirements.

Bulb diameter, mm	4.5 to 5.5
Distance, bottom of bulb to graduation at 30°C, mm	75 to 90
Distance bottom of bulb to graduation at 200°C, mm	333 to 354
Longer lines at each, °C	1
Figured at each, °C	5
Expansion chamber	To allow heating to 250°C
Scale error not to exceed, °C	±0.3

A-4. PREPARATION OF APPARATUS

A-4.1 The 100 mm thimble shall be polished to a mirror finish prior to each test with a suitable non-aqueous suspension of abrasive powder to remove carbon deposits and slight discolourations. If the thimble is marked by deep blue discolouration, it shall be rubbed with crocus cloth or suitable emery paper and then with the metal polish to a mirror finish.

A-4.2 Insert the polished thimble into a rolled No. 12 cork, bored to provide a tight fit. The face of the cork shall be flush with the open end of the thimble and shall permit the closed end to be exposed to a length of 80 mm.

A-4.3 Place the heater thermocouple wires lengthwise on the heater cartridge in such position that the junction will be 40 mm from the closed end of the thimble when in place. Insert the snugly fitting cartridge with the thermocouple wires into the thimble until the end of the cartridge is against the closed end of the thimble, carefully guiding the wires into the groove of the thimble.

A-4.4 Push the polished thimble-cork assembly firmly into heater chamber *A*. Centre the thimble in the heater chamber with the groove on the top side.

A-4.5 Place the air cooler in tube *B* and attach to the adjustable air supply with flexible tubing. The bottom of the cooler should be 30 mm above the junction of tube *B* and the connecting tube to the heating chamber.

A-4.6 Place the glass thermocouple well, with rolled No. 5 cork, in tube *C* so that the bottom of the cork is approximately 15 mm below the top of tube *C* and the tip is 140 mm below the centre of the short arm connecting tubes *B* and *C*, and carefully centre in tube *C*. Insert the thermocouple wires so that the junction is at the bottom of the glass well.

NOTE — If a thermometer is used in place of thermocouple, the cork is similarly placed in tube *C* to make a rigid setting, and the bottom of the bulb should be in the same position as the thermocouple well and carefully centered in tube *C*. Careful centering is required to obtain uniform temperatures at this point. A spiral made of a 6.4 × 150 mm piece of thin metal twisted three turns may be inserted in the bottom of tube *C* to better distribute the flow over the cross section of tube *C*.

A-4.7 Attach thermocouple wires on the outside of the air cooler in tube *B* so that the junction is 25 mm below the bottom of the air cooler and centered in tube *B*.

NOTE — The thermocouples in heater tube *A* and tube *B* may be omitted for routine work and where record of temperatures at these points is not required. It is generally satisfactory to set initially the heat input to the thimble using a variable transformer and to use this setting for subsequent tests.

A-4.8 Support the unit in a vertical position on a ring stand or other suitable support with two universal clamps near the ends of tube *B*. Then, with the aid of a 5 degree-angle wedge and spirit level, adjust the unit so that the top side of heater chamber *A* is exactly 5 degree off horizontal.

A-4.9 Secure the insulation in position around tube *A*.

A-4.10 Connect the wire from thermocouple junctions through a multiple switch to the temperature indicator.

A-5. PROCEDURE

A-5.0 Approximately 300 ml of the sample shall be used for the test.

A-5.1 Preheat the sample to 60 to 70°C and pour into tube *B* until the oil level is at the top of the short arm connecting tubes *B* and *C* when the air cooler is in its operating position. This will require about 300 ml of the oil.

A-5.2 Connect the heater to a variable electric power supply and adjust the voltage to provide a thimble temperature $175 \pm 2^\circ\text{C}$.

A-5.3 Turn on the air to the cooler so that it is noticeably felt by hand. After temperature equilibrium is obtained, adjust the air flow as required to maintain a temperature of $99 \pm 6^\circ\text{C}$ in tube *C*, and a suitable temperature differential between thermocouple junctions in tubes *B* and *C*.

NOTE — During the initial test period, the thimble cork should be inspected for oil leakage. If leakage occurs, the level of oil may drop below the short connecting arm and stop circulation, thereby preventing cooling and allowing the temperature of the heated oil to rise excessively.

A-5.4 Record temperatures at hourly intervals.

A-5.5 Six hours from the time the heater is turned on, disconnect the current to the heater and remove the cartridge and thermocouple. Increase the flow of cooling air for about 10 minutes.

A-5.6 Remove the cooler assembly from tube *B*, tilt and pour the oil out of the top of tube *B*.

A-5.7 Remove the thimble cork assembly taking care not to rub the thimble against the glass tube. Support the cork end with a clamp in a nearly

IS : 1593 - 1982

horizontal position with the groove side up and allow the residual oil to drain for 15 minutes.

NOTE — If a sediment line forms, it will be on the groove side of the thimble, thus the groove, when positioned on the top side at the start of test, will aid in locating the sediment line and in placing for proper draining after removal from the glass heater unit.

A-5.8 Observe the appearance of the deposit on the thimble. Then wash the closed end by immersing to the bottom of the cork in a 250-ml beaker filled with benzene and swirl gently to remove the oil. Repeat rinse in a second beaker filled to the same depth with clean benzene. Allow the benzene to evaporate from the thimble and observe the appearance of the washed thimble. Wipe a portion of the washed section with a clean soft cloth or paper tissue for any further observance of appearance.

A-5.9 Determine the rating of the thimble in accordance with Table 2.

TABLE 2 THIMBLE RATING

Sl. No.	THIMBLE RATINGS	THIMBLE SECTIONS		
		Unwashed	Unwiped, Washed	Wiped, Washed
i)	Stable	Clean oil film or lightly peppered only	Metal bright, negligible discolourations or films	Metal bright, no discolouration
ii)	Border line	Heavily peppered oil film or an annular streaked lines of sediment or evidence of the beginning of the formation of a film asphaltic smear	Thin oil-free layer of carbon varying in colour from a light tan to iridescent blue	Slightly darkened
iii)	Unstable	Thin to thick film of an asphaltic smear. This film may assume the appearance of concentric annular rings for very unstable products	Definite black carbon film which, depending on its thickness, may prove difficult to wash oil-free	Definite discolouration or darkened

APPENDIX B

(Clause 4.1.2)

TEST FOR EXPLOSIVENESS

B-1. SCOPE

B-1.1 This method of test is intended for field use in the determination of the approximate percent explosiveness of gas and vapour mixtures given off by fuel oil under specified conditions.

B-2. APPARATUS

B-2.1 Explosimeter — a combustible gas indicator, with a graduated scale indicating degree of explosiveness. The explosimeter shall be calibrated before each test as described in B-4.

B-2.2 Thermometer — Covering the approximate range from 38 to 88°C graduated in 0.5°C subdivisions or finer.

B-2.3 Water-Bath — Suitable for heating a one-litre bottle of the fuel oil.

B-2.4 Sample Bottle — one-litre capacity.

B-2.5 Test Bottles — Two 1-litre bottles, equipped as specified in B-2.5.1 and B-2.5.2 (see Fig. 2).

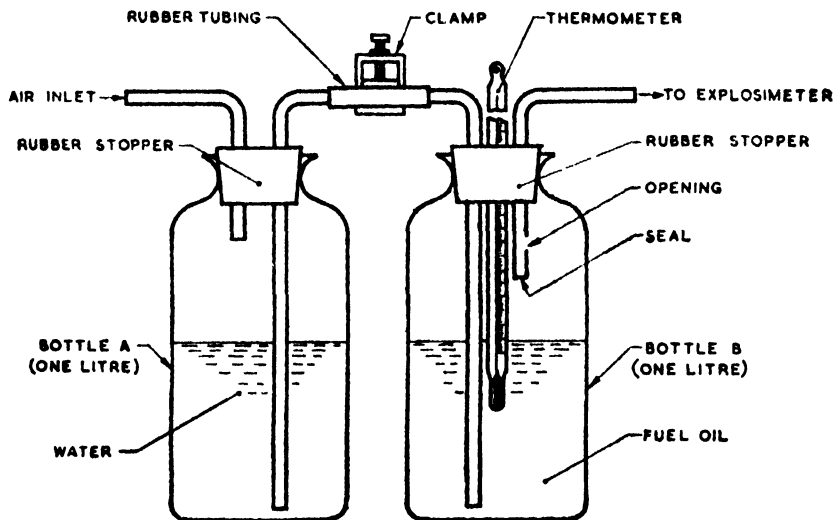

FIG. 2 ASSEMBLY OF TEST APPARATUS

B-2.5.1 Bottle A — Insert a two-hole rubber stopper into the mouth of the bottle *A*, with a glass tube bent at 90° in one opening extending just below the stopper and with another glass tube bent at 90° in the other opening extending almost to the bottom of the bottle.

B-2.5.2 Bottle B — Insert a three-hole rubber into the mouth of the bottle *B*. The thermometer is inserted in one opening so that the bulb is about three-quarters of the distance to the bottom of the bottle. A glass or copper* tube bent at 90° is inserted in the second opening, extending approximately 25 mm below the bottom of the stopper. This glass (or copper) tube shall have a small opening about midway between the lower end of the tube and the bottom of the stopper (see Fig. 2). The third opening shall be fitted with a glass tube bent at 90° extending almost to the bottom of the bottle. The external end of this glass tube shall be fitted with a short length of rubber tubing and a screw clamp (see Fig. 2).

B-2.6 Volumetric Flask — A volumetric flask of 2-litre capacity. This flask shall be equipped with a two-hole rubber stopper fitted with a long glass tube which extends almost to the bottom of the flask and a short tube which extends only to the bottom of the stopper. The external ends of these glass tubes shall be bent at right angles and shall be fitted with short lengths of rubber tubing and with pinch clamps.

B-2.7 Graduated Cylinder — A graduated cylinder of 100-ml capacity (see IS : 878-1975†).

B-2.8 Drying Tube — A drying tube containing calcium chloride and fitted with a short length rubber tubing for attaching to the explosimeter.

A-2.9 Aspirator Bulb — Any rubber aspirator bulb in good condition is satisfactory.

B-3. SAMPLING

B-3.1 A representative sample of the material (1 litre) to be tested shall be obtained in the sample bottle. Leaving a minimum of vapour space, the sample bottle shall be closed immediately with a tightly fitting stopper which shall not be removed prior to removal of a portion of the material for test. After the test portion has been removed, the remaining material shall not be used for further testing.

B-4. CALIBRATION OF EXPLOSIMETER

B-4.1 Any hydrocarbon gas may be used for the calibration of the explosimeter, provided its lower explosive limit is known in terms of volume percent gas.

*A copper tube is preferred for safety reasons.

†Specification for graduated measuring cylinders (first revision).

IS : 1593 - 1982

B-4.2 Transfer approximately 500 ml of water to the volumetric flask. Close with a stopper, and invert in a water-bath. Remove the stopper and support the flask so that the graduation mark is at the level of the water in the bath.

B-4.3 Place the graduated cylinder in the water-bath and when completely filled, invert and support in a vertical position. Compute the volume of hydrocarbon gas which will give a mixture of 50 percent explosiveness when diluted with air to a total volume of two litres. Adjust the level of the inverted graduated cylinder so that the graduation mark corresponding to the above-computed volume of hydrocarbon gas is at the level of the water in the bath.

B-4.4 Into the inverted graduated cylinder, introduce the hydrocarbon gas until the water levels are the same inside and outside the cylinder.

B-4.5 Release the support holding the graduated cylinder, and slowly bring it under the neck of the volumetric flask in such a manner that all of the hydrocarbon gas is quantitatively transferred to the volumetric flask. Then, with the aspirator bulb, introduce air into the volumetric flask until water levels are the same inside and outside of the flask.

B-4.6 While still immersed, insert the two-hold rubber stopper into the mouth of the volumetric flask, and tighten the screw clamps on the rubber tubes attached to the two glass tubes. Remove the flask from the water-bath and invert several times. Then connect the bottle *A* (approximately half full of water) as illustrated in Fig. 2, except that the volumetric flask takes the place of the bottle *B*.

B-4.7 Attach the calcium chloride drying tube to the inlet side of the explosimeter, and attach the short glass tube in the volumetric flask to the other end of the drying tube. Adjust the needle of the explosimeter to zero. Release the clamp between the volumetric flask and the drying tube, apply air pressure to the inlet of bottle *A* and gradually release the clamp between bottle *A* and the volumetric flask. This will permit water to flow into the volumetric flask, thereby forcing the combustible mixture through the explosimeter. The rate of flow should be adjusted to about 500 ml in 20 seconds, and should be uniform.

B-4.8 Immediately after starting the flow of combustible mixture, observe the reading of the explosimeter and continue to observe it until the reading reaches an equilibrium explosimeter reading.

B-4.9 The explosimeter shall be calibrated before each test.

B-5. TEST PROCEDURE

B-5.1 Fill half of the bottle *B* (see Fig. 2) with the material to be tested and replace the remaining portion of the material in sampling bottle.

IS : 1593 - 1982

Immediately insert into the mouth of the bottle *B* the rubber stopper with the two glass tubes and the thermometer in place. Draw up the short glass exit tube until the side opening is closed by the stopper and close the end of the long tube with the screw clamp.

B-5.2 Bring the water in the water-bath to a temperature of 66 to 69°C and immerse the closed bottle *B* in the water-bath. Shake the bottle occasionally, and leave it immersed until the temperature of the material in the bottle reaches 52°C. With material originally at room temperature, it should heat up to 52°C in approximately 5 to 10 minutes.

B-5.3 When the temperature of the material in the bottle reaches 52°C, remove the bottle and shake vigorously for a total of five minutes, with periodic immersion of the bottle in the water-bath in order to maintain the fuel oil temperature at 52°C during the shaking process.

B-5.4 Fill approximately half of the bottle *A* with water at about 52°C and as soon as the bottle *B* has been shaken as described in B-5.3 for five minutes, connect the two bottles as shown in Fig. 2. Connect the short exit tube from bottle *B* to the explosimeter. Adjust the needle of the explosimeter to read zero, and then push the short tube down in the rubber stopper until the side opening in this tube is exposed below the rubber stopper.

B-5.5 Apply air pressure to the inlet to the bottle *A* and slowly open the screw clamp between the bottle *A* and *B*. This permits flow of water from the bottle *A* into the bottle *B*, thereby displacing the vapour mixture out of the bottle *B* and through the explosimeter. The displacement should be conducted cautiously and at a uniform rate over a period of approximately 20 seconds.

B-5.6 Observe the reading of the explosimeter throughout the entire displacement period and record the equilibrium value reached.

B-5.7 As soon as the explosimeter reading has reached a constant value, stop the displacement of vapour mixture in order to prevent material from passing into the explosimeter.

B-6. INTERPRETATION OF RESULTS

B-6.1 The material is considered to have passed the test if the explosimeter reading obtained by following the procedure outlined in B-5 is equal to or lower than the calibration equilibrium reading obtained under B-4.8.

IS : 1593 - 1982

(Continued from page 2)

<i>Members</i>	<i>Representing</i>
SHRI S. K. BASU	Directorate General of Technical Development, New Delhi
SHRI K. V. SAMPATH (Alternate)	
SHRI P. N. BHAMBHI	Indian Institute of Petroleum (CSIR), Dehradun
SHRI S. CHAKLADAR (Alternate)	
SHRI G. C. GOSWAMI	Indian Oil Corporation Ltd (Assam Oil Division), Digboi
SHRI I. GHANDRA (Alternate)	
SHRI A. JANAKIRAMAN	Indian Oil Corporation Ltd (Marketing Division), Bombay
SHRI P. SUDARSANAM (Alternate)	
SHRI A. T. JOSEPH	Indian National Ship Owner's Association, Bombay
SHRI R. G. SATHAYA (Alternate)	
SHRI C. P. KHARE	Railway Board (Ministry of Railways)
CDR L. A. LOWE	Naval Headquarters
LT M. GEORGE (Alternate)	
SHRI A. K. MANDAL	Petroleum Conservation Research Association, New Delhi
SHRI MANUEL KARNA	Cochin Refineries Ltd, Cochin
SHRI P. K. MAZUMDAR	Ministry of Defence (DGI)
SHRI V. L. LALCHANDANI (Alternate)	
SHRI S. R. MEHTA	Hindustan Petroleum Corporation Ltd, Bombay
SHRI C. V. RAMASWAMY (Alternate)	
SHRI K. U. RAO	Hindustan Petroleum Corporation Ltd, Vishakhapatnam
SHRI P. V. MORE (Alternate)	
SHRI R. L. SACHCHAR	The Shipping Corporation of India Ltd, Bombay
SHRI M. M. PIPLANI (Alternate)	
SHRI J. M. SAGAR	Indian Oil Corporation Ltd (R & D), Faridabad
SHRI FAKIRA SINGH (Alternate)	
DR R. D. SRIVASTAVA	Ministry of Defence (R & D)
DR P. S. VENKATARAMANI (Alternate)	
SHRI E. F. SURTI	Tata Iron & Steel Co Ltd, Jamshedpur
SHRI S. VAIDYANATHAN	Steel Authority of India (Durgapur Steel Plant)
SHRI T. V. VAROHESE	Madras Refineries Ltd, Madras
SHRI P. C. D. G. SAMUEL (Alternate)	

BUREAU OF INDIAN STANDARDS

Headquarters:

Manak Bhavan, 9 Bahadur Shah Zafar Marg, NEW DELHI 110002
 Telephones: 323 0131, 323 3375, 323 9402 Fax :+ 91 011 3234062, 3239399, 3239382
 E - mail : bis@vsnl.com. Website : http://www.bis.org.in

Central Laboratory :

Plot No. 20/9, Site IV, Sahibabad Industrial Area, Sahibabad 201010 **Telephone**
 477 00 32

Regional Offices:

Central : Manak Bhavan, 9 Bahadur Shah Zafar Marg, NEW DELHI 110002 **323 76 17**

*Eastern : 1/14 CIT Scheme VII, V.I.P. Road, Kankurgachi, KOLKATA 700054 **337 86 62**

Northern : SCO 335-336, Sector 34-A, CHANDIGARH 160022 **60 38 43**

Southern : C.I.T. Campus, IV Cross Road, CHENNAI 600113 **254 13 15**

†Western : Manakalaya, E9, MIDC, Behind Marol Telephone Exchange, Andheri (East), MUMBAI 400093 **832 92 95**

Branch Offices:

'Pushpak', Nurmohamed Shaikh Marg, Khanpur, AHMEDABAD 380001 **550 13 48**

Peenya Industrial Area, 1st Stage, Bangalore-Tumkur Road, BANGALORE 560058 **839 49 55**

Commercial-cum-Office Complex, Opp. Dushera Maldan, E-5 Arera Colony, Bittan Market, BHOPAL 462016 **72 34 52**

62/63, Ganga Nagar, Unit VI, BHUBANESWAR 751001 **40 36 27**

5th Floor, Koval Towers, 44 Bala Sundaram Road, COIMBATORE 641018 **21 88 35**

Plot No. 58, Neelam Bata Road, NIT, FARIDABAD 121001 **542 82 61**

Savitri Complex, 116 G.T. Road, GHAZIABAD 201001 **471 19 98**

53/5 Ward No.29, R.G. Barua Road, 5th By-lane, Apurba Sinha Path, GUWAHATI 781003 **54 11 37**

5-8-56C, L.N. Gupta Marg, Nampally Station Road, HYDERABAD 500001 **320 10 84**

E-52, Chitrangan Marg, C- Scheme, JAIPUR 302001 **37 38 79**

117/418 B, Sarvodaya Nagar, KANPUR 208005 **21 68 76**

Seth Bhawan, 2nd Floor, Behind Leela Cinema, Naval Kishore Road, LUCKNOW 226001 **21 89 23**

NIT Building, Second Floor, Gokulpat Market, NAGPUR 440010 **52 51 71**

Mahabir Bhawan, 1st Floor, Ropar Road, NALAGARH 174101 **2 14 51**

Patliputra Industrial Estate, PATNA 800013 **26 28 08**

First Floor, Plot Nos. 657-660, Market Yard, Ghatkoti, PUNE 411037 **428 86 59**

'Sahajanand House' 3rd Floor, Bhaktinagar Circle, 80 Feet Road, RAJKOT 360002 **37 82 51**

T.C. No. 14/1421, University P. O. Palayam, THIRUVANANTHAPURAM 695034 **32 21 04**

*Sales Office is at 5 Chowringhee approach, P. O. Princep Street, KOLKATA 700072 **237 10 85**

†Sales Office is at Novelty Chambers, Grant Road, MUMBAI 400007 **309 65 28**