

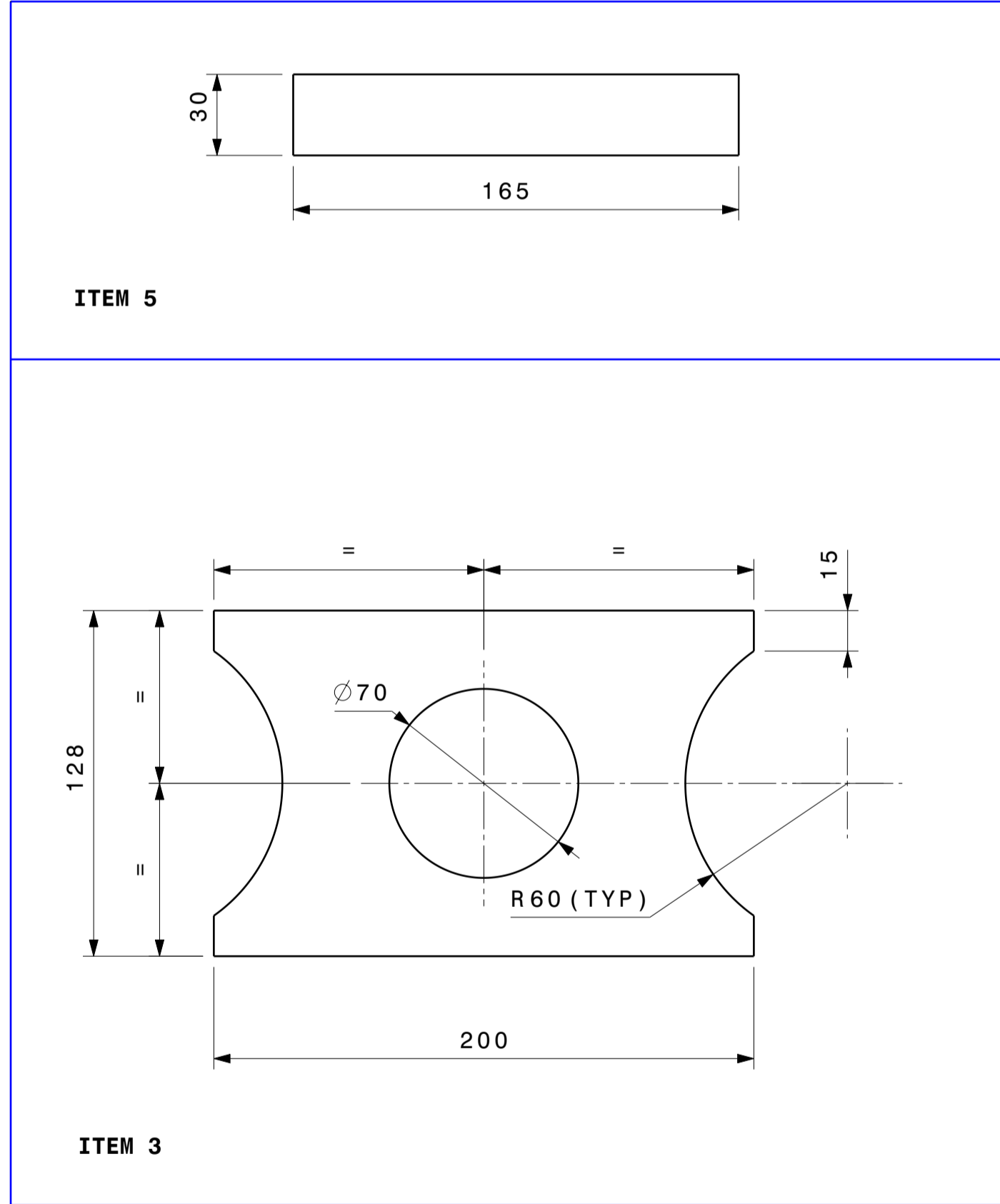

This design is strictly private and confidential. It is the exclusive property of Ashok Leyland Ltd., and must not be used, copied or reproduced in part or whole without the company's written permission.

ASHOK LEYLAND LTD. TECHNICAL CENTRE, VELLIVOLCHAVADI

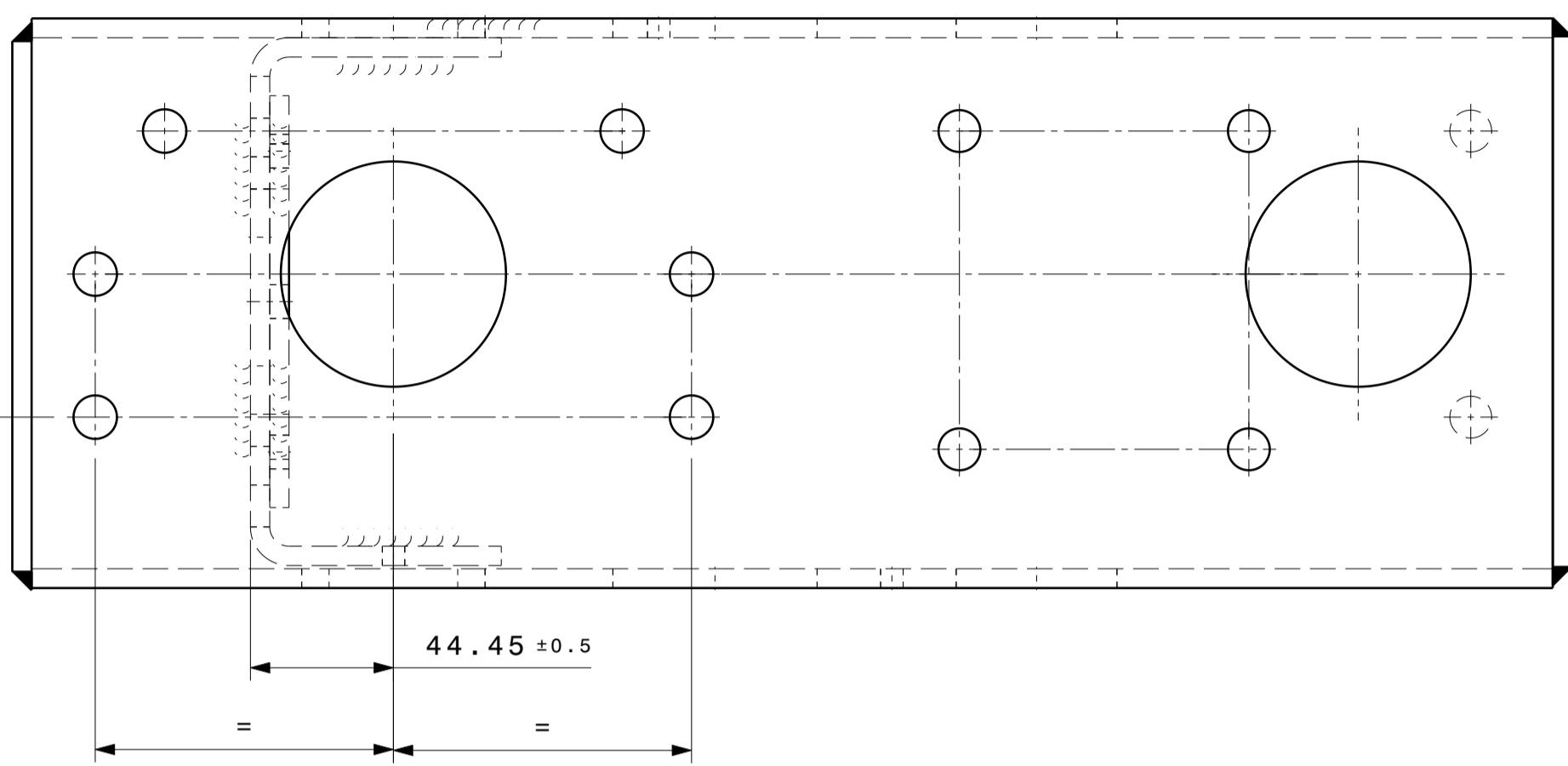
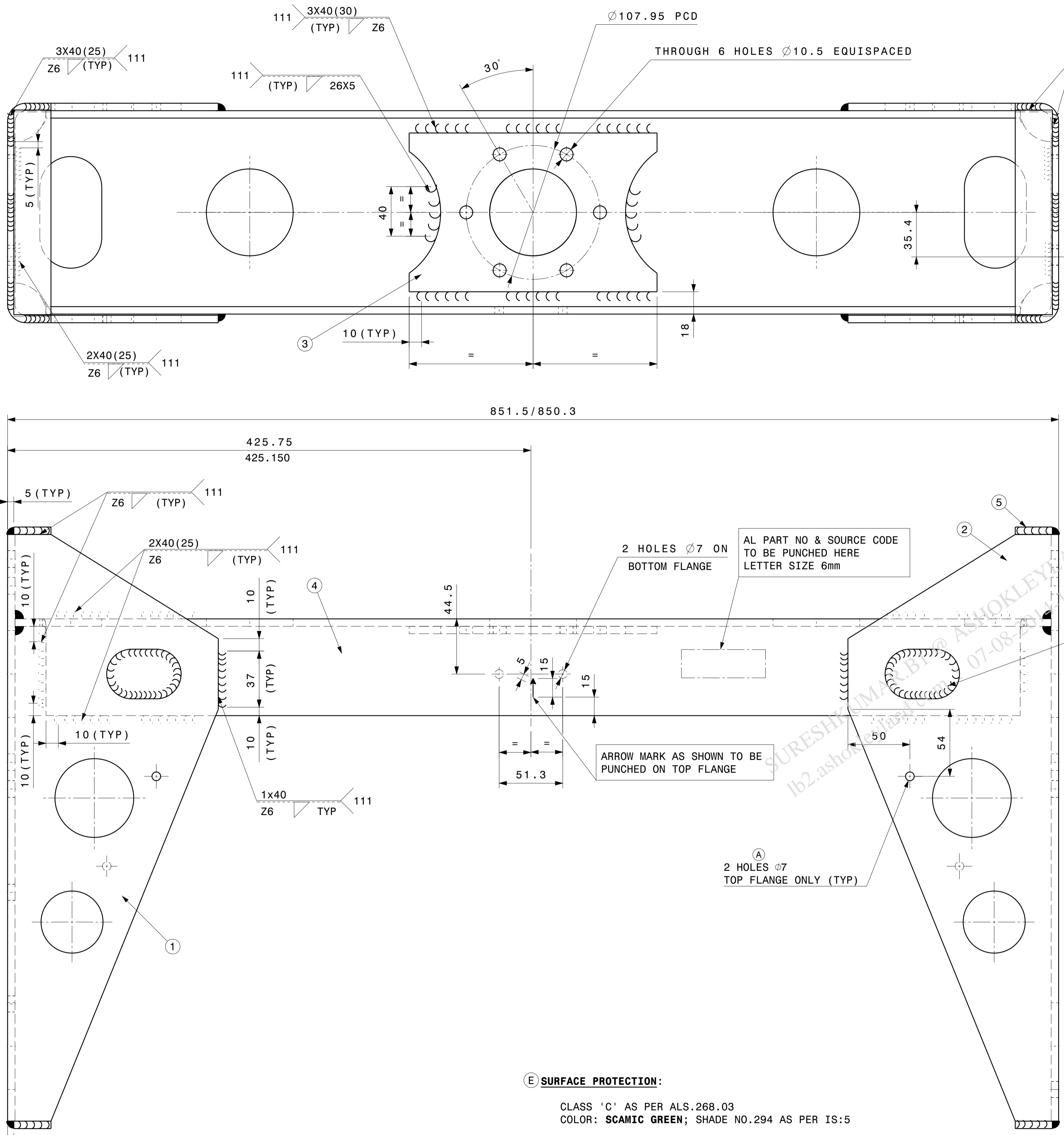

(E) SURFACE PROTECTION:
 CLASS 'C' AS PER ALS.268.03
 COLOR: SCAMIC GREEN; SHADE NO.294 AS PER IS:5

WELD NOTE:
 WELDING ELECTRODES TO CONFORM TO AWS E6012/E6013
 WELD SPECIFICATION CONFORM TO ALS 276.02

ALTERATIONS	DR. DATE	ISSUE	REVISION
TWO HOLES Ø7 ADDED	21/09/02	-	A
PAINTING DETAILS UPDATED DIN:023048 ABM	23/03/05	-	B
VIEW CORRECTED FOR HOLE LOCATION IN ITEM1 IN LINE WITH INDVL. DRG DIN:023215 AA/SN	06/05/06	-	C
*DRG RE-DRAWN IN CAD *NOTE ENAMEL REQUIREMENT TO IS 8982 DELETED *OTHER SPECIAL INSTRUCTION NOTES ADDED. SG/KG	20/07/10	-	C.1
CAD DRG UPDATED FOR PLM ERROR. MDK/AYR	06.12.12	-	D
-DRG UPDATED FOR END GUSSETS THRU HOLE Ø50 WAS Ø63.5. -ITEM 3 AND 5 MATERIAL IS 2062 E250 Gr 'A' WAS IS 2062 Gr 'A'. -SURFACE PROTECTION UPDATED. KV/BSV	17-04-14	-	E

REVISION	DATE	STATUS
REVISION : E	DATE : 6/5/2014	STATUS : RELEASE
STAGE : III	ER-DIN NO : ER-DIN-002882	DATE : 6/5/2014
ALTERED BY : sundaralvc	CHECKED BY : sureshmarb1	
MED APPROVAL : sunilrajs	APPROVED BY : rikaivc	
DIGITALLY SIGNED. PHYSICAL SIGNATURE NOT REQUIRED		
DRAWN / DATE	CHECKED / DATE	MED APPROVAL / DATE
20/03/02	ABM 24/04/02	CS 11/08/03
APPROVED / DATE	MRK 29/04/02	
STDS APP / DATE		
MATERIAL		
HEAT TREATMENT		
REMARKS		
STALLION 4X4 MARK IV		
DESCRIPTION		
CROSS MEMBER - AGB RR		
PART No.	B 8 1 3 6 5 0 3 E	
SHEET NO.1.....OF.....1.....		

SL.No.	PART NO.	DESCRIPTION	MATERIAL	QTY.
5	ITEM 5	END PLATE	PLATE 6 THK IS 2062 E250 Gr 'A'	4
4	X4675414	X - MEMBER	REF DRG	1
3	ITEM 3	STIFFENER PLATE	6 THK IS 2062 E250 Gr 'A'	1
2	X4632314	GUSSET RH	REF DRG	1
1	X4632214	GUSSET LH	REF DRG	1

BILL OF MATERIALS			
APPEARANCE ITEM	ER-DIN	DATE	
YES	NO	ER-DIN-	
FINISHED WEIGHT (APPROX)	REF. PT. NO.	B1080503	
SCALE	S/A PT No.	A8136500	
1:2	SUPERSEDES		
	SPEC NO.	HAF147	

UNLESS OTHERWISE SPECIFIED	
ASHOK TOLERANCES	REFER IS:2102 : MEDIUM FOR MACHINING AND COARSE FOR FABRICATION
SURFACE PROTECTION	FABRICATED COMPONENTS TO BE DEGREASED, DEGAOSED, APPLY ZINC PHOSPHATE, APPLY EPOXY PRIMER AND APPLY BLACK ENAMEL TO MEET 900 HRS OF SALT SPRAY LIFE WHEN TESTED AS PER ASTM D117 UNDER PELLICULAR CORROSION. NO DISFERRING IS ALLOWED. MACHINED SURFACE TO BE APPLIED WITH RUST PREVENTIVE OIL TO IS 1154
SURFACE FINISH AS PER IS:3073 (CLA VALUE)	METRIC BOREN THREADS SHALL CONFORM TO THE LIMITS AND TOLERANCES SPECIFIED IN THE CURRENT IS:4218 CLASS-06 EXTERNAL OR-5H INTERNAL. SHARP EDGES TO BE REMOVED DIMENSIONS ARE IN MM DO NOT SCALE DRAWING

- SPECIAL INSTRUCTIONS/NOTE:**
1. GENERAL TOLERANCE TO BE ±0.5MM
 2. TOLERANCE ON HOLE PITCHES & SIZES TO BE ±0.25MM.
 3. TOLERANCE ON OVERALL DIMNSIONS TO BE ±1MM
 4. BEND LINE TO BE ⊥ TO GRAIN FLOW DIRECTION.
 5. WELDING FILLET SIZE 6 mm.
 6. TO BE PAINTED WITH ENAMEL, SCAMIC GREEN CONFORM TO AL. PT:X9715000