

**MATERIAL :-** SPRING STEEL WIRE TO SPECN. B.S: 1408-C

4 SHEET 9 OF 9

**WORKMANSHIP & FINISH :-** TO BE SMOOTHLY FINISHED AND CADMIUM PLATED TO A MINIMUM THICKNESS OF 0.012 mm. AND CHROMATE PASSIVATED AS PER SPECN. IS: 1572-1968, Cd-12.

**EMBRITILEMENT RELEASE :-** PINS, AFTER CADMIUM PLATING AND PRIOR TO CHROMATE PASSIVATION SHALL BE MAINTAINED AT A TEMP. OF 150°-200°C FOR NOT LESS THAN HALF AN HOUR TO REMOVE HYDROGEN EMBRITILEMENT.

**TOLERANCES :-** ± 0.4 mm, UNLESS OTHERWISE SPECIFIED.

**PACKING :-** EACH PIN SECURING FLAP ALONG WITH A LABEL OF SUITABLE SIZE

HAVING NOMENCLATURE OF STORE, YEAR OF MANUFACTURE, MANUFACTURER'S NAME AND ADDRESS AND THE INSPECTOR'S STAMP, SHALL BE KEPT IN A POLYETHENE BAG OF SUITABLE SIZE OF 150 GAUGE. OR AN APPROVED GAUGE AVAILABLE. 25 Nos. OF SUCH BAGS SHALL BE KEPT IN A CARTONS OF SUITABLE SIZE OF APPROVED QUALITY. EACH CARTONS SHALL BE IDENTIFIED BY A LABEL OVER IT SHOWING NOMENCLATURE, TRADE MARKS/INITIAL OF MANUFACTURE, YEAR OF MANUFACTURE, QTY. IN THE CARTONS. 10 CARTONS SHALL THEN BE PACKED IN C.W.P. OF SUITABLE SIZE OF APPROVED QUALITY.

BEFORE DESPATCH EACH PACKING CASE SHALL BE LEGIBLY AND INDELIBLY MARKED WITH THE FOLLOWING DETAILS :-

- (i) NOMENCLATURE, CAT. NO. AND YEAR OF MANUFACTURE OF THE STORE.
- (ii) TOTAL No. OF PACKING CASES AND No. OF INDIVIDUAL PACKING CASE IN A CONSIGNMENT.
- (iii) MASS OF PACKING CASE IN KG.
- (iv) ADDRESS OF THE CONSIGNEE.
- (v) ADDRESS OF THE CONSIGNOR.

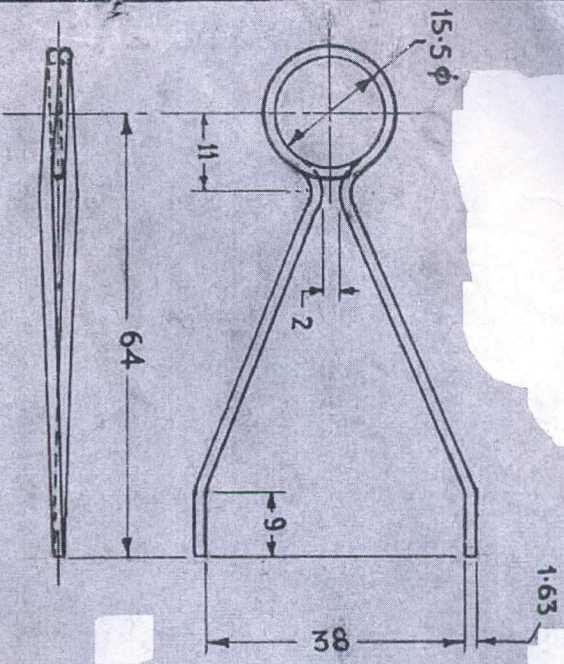

**NOTE: ENVIRONMENTAL TEST- SALT SPRAY TEST SHALL BE CARRIED OUT AS PER SCHEDULE.**

COUNTERSIGNED.

DGN.	DATE	NAME
DRN.		(SITA RAM)
CHD.	3-6-75	
TRD.		
COMP.	22-8-76	
AD/DO		
PROOFFR	13/11/11	

SCALE :- 1:1

27L/3502 DROGUE WITHDRAWAL LINE  
(PIN SECURING FLAP)



THIRD-ANGLE PROJECTION

DIMENSIONS IN MILLIMETRES.

APPROVED.

*R. S. Srinivas*  
DY. DIR.

PROV.

DRG. No. ADRDE/7865A-3

00/124/78