

UNSPECIFIED TOL ARE AS PER FINE IS 2102

TOL ON PT	TOL ON PT
φ 2.4 H7	+0.010 -0.000
φ 2.4 S6	+0.020 +0.014
φ 3.5 C11	+0.145 +0.07

ABOVE UPTO & INCLUDING	TOL			
	06	30	120	315
06	±0.05	±0.1	±0.15	±0.2
30	±0.05	±0.1	±0.2	±0.3
120	±0.05	±0.1	±0.2	±0.3
315	±0.05	±0.1	±0.2	±0.3
1000	±0.05	±0.1	±0.2	±0.3

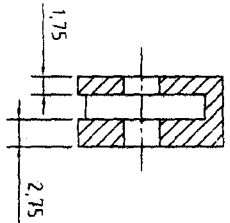

SECTION A-A

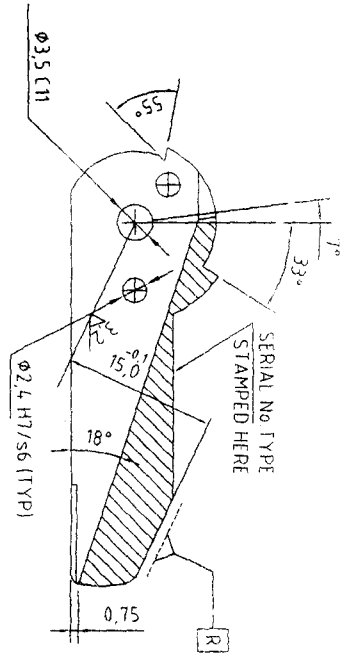

SECTION B-B

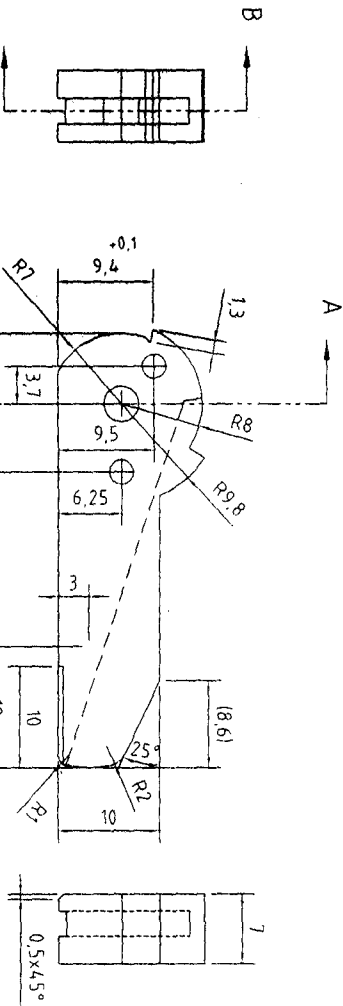

ALL MATERIAL: EN398, BS.970 P11-1983 OR THROUGH MIN ROUTE

HEAT TREATMENT: ALL SURFACE HARDENED TO 450-550 VHN TO THE DEPTH OF 0.3mm TO 0.6mm

SCALE: 1:1

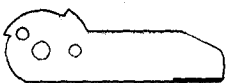

NOTES:  
1 ALL SHARP EDGES TO BE SMOOTHLY ROUNDED OFF  
2 ONE SAMPLE TO BE TRIED BEFORE PLACING BULK ORDER  
3 MANUFACTURES INITIAL/CODE NO. YEAR OF MANUFACTURE SHOULD BE ENGRAVED AT SUITABLE PLACE

FOR THE COPY OF  
DRAWING / LAYOUT / GAUGE SCHEDULE  
PLEASE CONTACT / AT THIS DATE / ISHAPORE  
RIFLE FACTORY, ISHAPORE

1 ALL SHARP EDGES TO BE SMOOTHLY ROUNDED OFF  
2 ONE SAMPLE TO BE TRIED BEFORE PLACING BULK ORDER  
3 MANUFACTURES INITIAL/CODE NO. YEAR OF MANUFACTURE SHOULD BE ENGRAVED AT SUITABLE PLACE

ALL DIMENSIONS ARE IN MILLI METRE  
IMPORTANT DIMENSIONS MARKED THIS TO BE MARKED ON

MATL	IS-4368-1967 GD 15, N14 Cr-1	OPERATION	DESIGNED	2013	NAME	DATE
TITLE OF			DRAWN		A.K.DHRIYA	
ORDNANCE FACTORY BOARD RIFLE FACTORY ISHAPORE			CHECKED			
			APPROVED			

HAMMER  
12 BORE PUMP ACTION GUN

DRG NO.:  
PAG-0060 A  
SHEET-1 OF-1