

MATERIAL : AISI / SAE 4630, MIN. 4630 OR EQUIVALENT
HARDNESS : 60-66 HRC
SUPPLY CONDITION : MANGANESE PHOSPHATED
RIFLE FACTORY, ISHAPORE
DRG. NO. - RFI.SK 101119

HOS/MPM
 7.02 भारतीय शस्त्र / CERTIFIED COPY OF
 शस्त्र / लेआउट / गेज चिह्न
 DRG/LAYOUT/GAUGE SCHEDULE
 निकाल / AT THIS DATE. 15.06.2017
 शस्त्र शि / CDD
रिफल फॅक्ट्री, इशापुर
RIFLE FACTORY, ISHAPORE

NOTE:-
 1. ALL DIMENSIONS ARE IN MM.
 2. GENERAL TOLERANCES ARE AS PER ISO 2768 (M).

HAMMER, MK. 2
 (THROUGH MM ROUTE)
 DRG. REF. NO. - D.S.CAT 1005-003160
 DRG. NO. - RFI.SK 101119

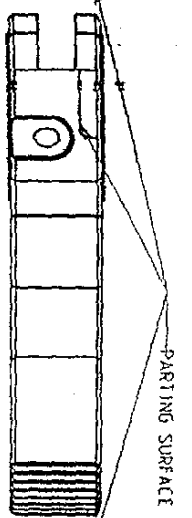

EJECTOR PIN MARKS
DEPRESSION 0.1 MAX.

SLEEVE EJECTION MARKS
DEPRESSION 0.3 MAX.

NO PIN MARKS ALLOWED ON THE
ZONE 'X' BOTH SIDES OF HAMMER

ZONE 'X'

CAVITY ID MARK AS #1.2...
DEPRESSION 0.2 MAX.
(APPLICABLE FOR MULTI CAVITY)

YEAR ID MARK AS '76'(2016)
DEPRESSION 0.2 MAX.

MIN. PROCESS ID MARK
AS 'T' DEPRESSION
0.2 MAX.
MANUFACTURING ID MARK
AS '1' DEPRESSION 0.2 MAX.

DETAIL A
SCALE 1,000

SEE DETAIL A

PARTING LINE MARKS
MISMATCH 0.05 MAX.
(WILL BE WITHIN THE
TOLERANCE SPECIFICATION)

SLIDELAND INSERT LINE
MARKS MISMATCH 0.05 MAX.
(WILL BE WITHIN THE
TOLERANCE SPECIFICATION)

GATE MARK DEPRESSION 0.2 MAX/
PROTRUSION NOT ABOVE
THE SURFACE 'A'

NOTES:
VOLUME OF THE PART = 2.49 CC
MINIMUM WALL THICKNESS = 1.04MM

HAMMER, MK. 2
(THROUGH MIN. ROUTE)
DRG. REF. NO. - D.S.CAT 1005-003160
DRG. NO. - RFLSK 10119

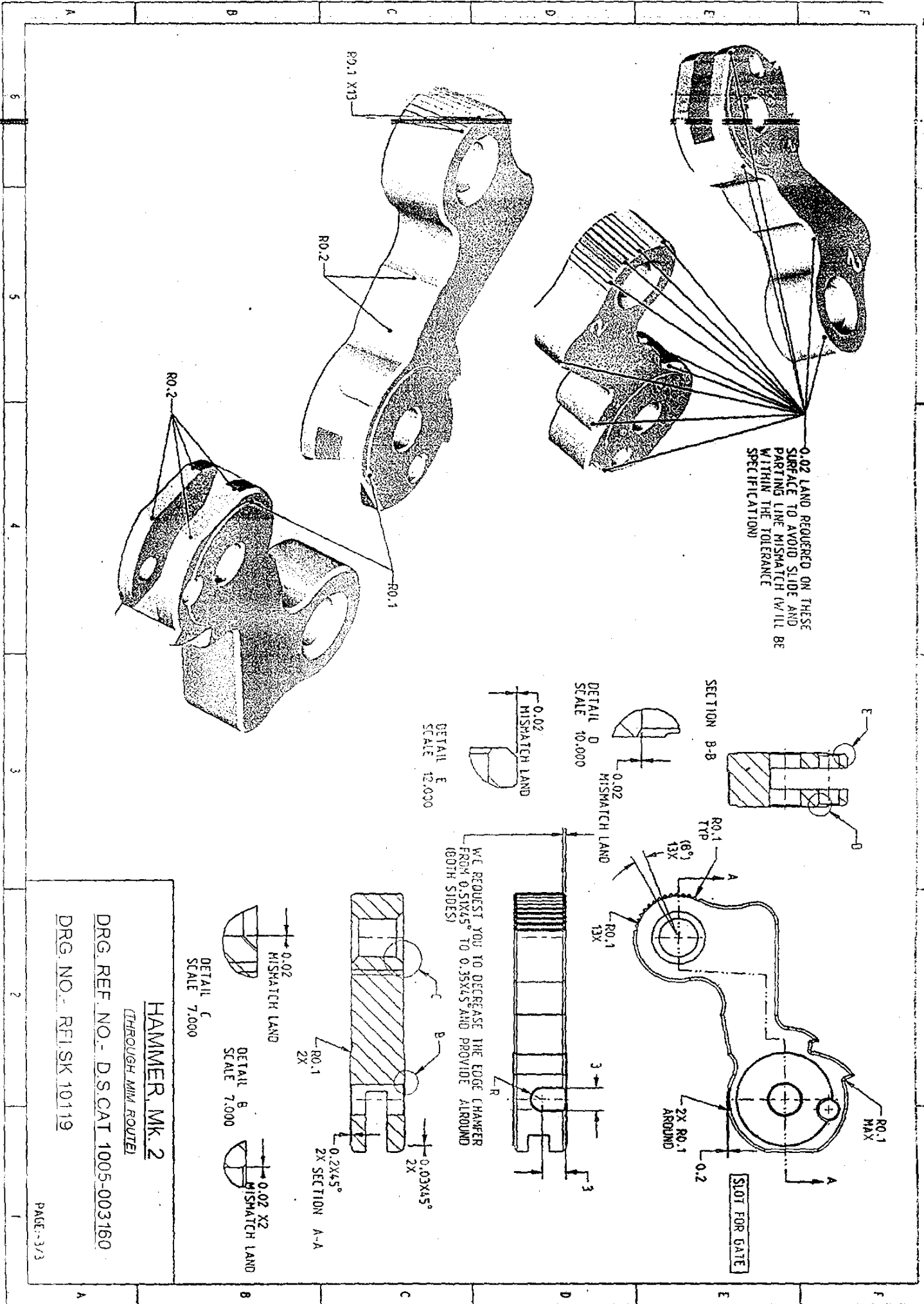

0.02 LAND REQUIRED ON THESE SURFACE TO AVOID SLIDE AND PARTING LINE MISMATCH (WILL BE WITHIN THE TOLERANCE SPECIFICATION)

SECTION B-B

DETAIL D SCALE 10:000

DETAIL E SCALE 12:000

WE REQUEST YOU TO DECREASE THE EDGE CHAMFER FROM 0.51x45° TO 0.35x45° AND PROVIDE IT AROUND (BOTH SIDES)

DETAIL C SCALE 7:000

DETAIL B SCALE 7:000

DETAIL X2 MISMATCH LAND

HAMMER, MK. 2

(THROUGH MM ROUTE)

DRG. REF. NO. - D.S. CAT 1005-003160

DRG. NO. - RFLSK 10119