

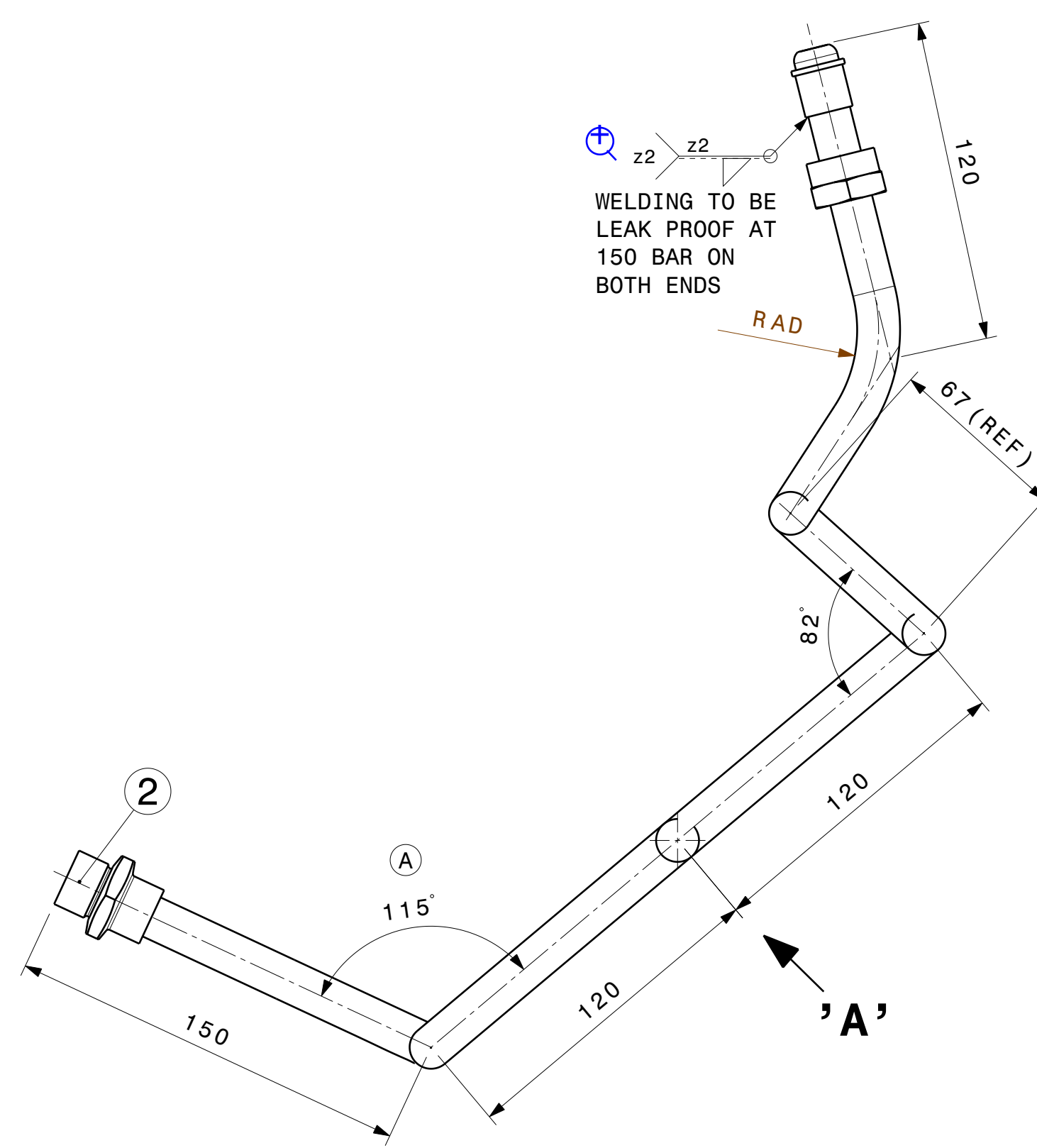

This design is strictly private and confidential. It is the exclusive property of Ashok Leyland Ltd., and must not be used, copied or reproduced in part or whole without the company's written permission.

ASHOK LEYLAND LTD. TECHNICAL CENTRE, VELLIVOYALCHAVADI

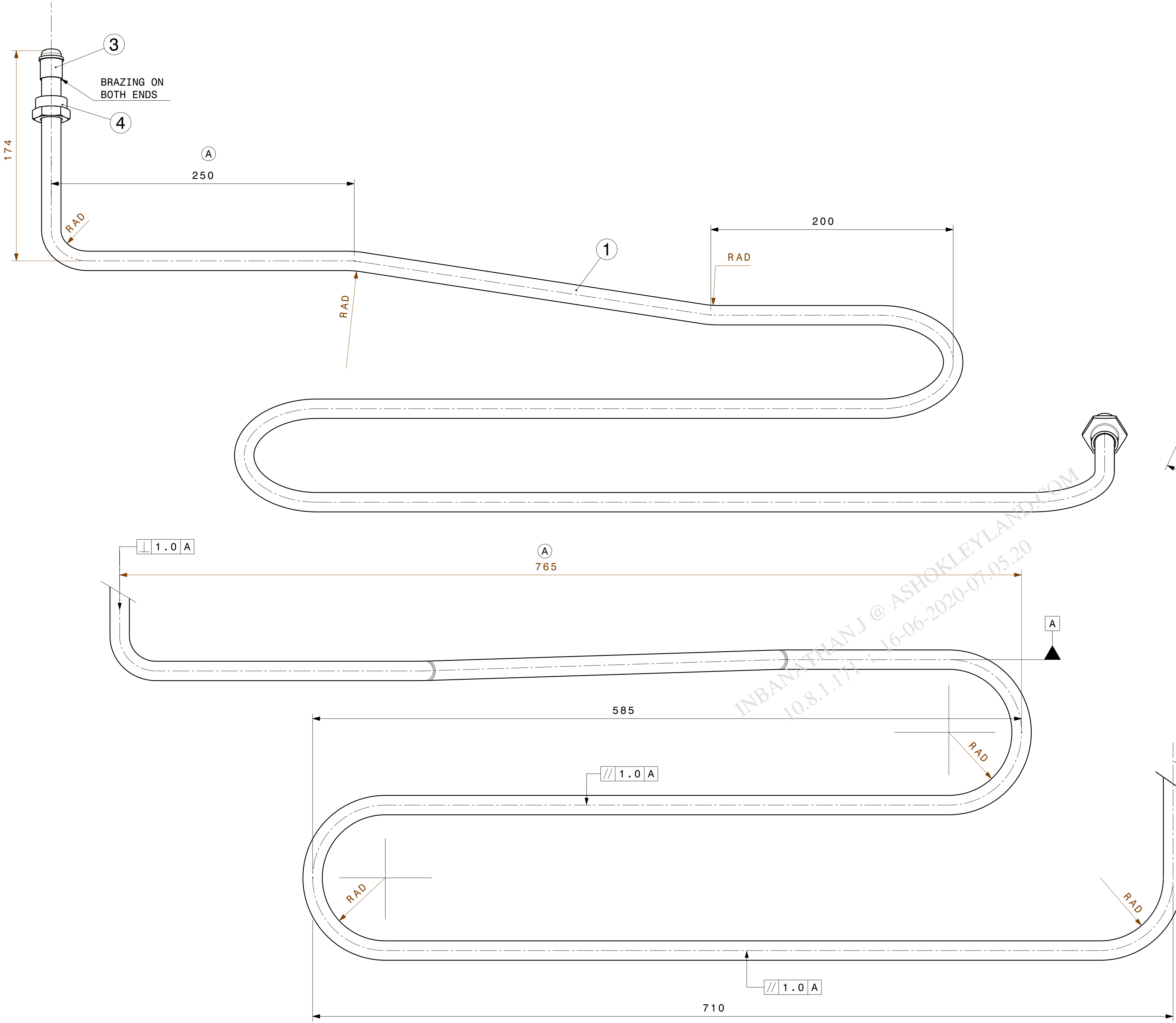

WELDING TO BE LEAK PROOF AT 150 BAR ON BOTH ENDS

VIEW 'A'

NOTE:-
 - THIS DRG FOR REFERENCE PURPOSE ONLY
 - FOR BULK PRODUCTION MASTER SAMPLE TO BE GIVEN BY P.D.

SPECIAL INSTRUCTIONS/NOTE:
 - HYDRAULIC TEST TO BE DONE AS PER IS-3074
 - FOR PLATING DETAILS REFER DRG:-F9615000
 - LIMIT OF DEVIATION FROM ROUNDNESS AFTER FORMING SHOULD NOT BE MORE THAN 10% OF NOMINAL OUTER DIA OF TUBE (AS PER IVECO STD 10.4418 CLASS 4.1.2)
 - BRAZING TO BE LEAK PROOF AT A PRESSURE OF 150 BAR.(AS PER ALS 276.01)

ALTERATIONS		ER-DIN DATE	ISSUE	REPLY
MATL. UPDATED FOR ITEM1 DISCRPTION CHANGED DIN:023739 EA/SN		26/08/06	—	A
IN ITEM NO. 2:- PT.NO.F0154915 WAS X0127515 IN ITEM NO. 3:- PT.NO.F2901615 WAS F2939715 IN ITEM NO. 4:- PT.NO.F2935015 WAS F2939915 DIN:023855 EA/SN		25/09/06	—	B

AL PLM VAULT
 REVISION : B.0 DATE : 8/12/2010 STATUS : RELEASE
 STAGE : III ER-DIN NO : ER-DIN-0006140 DATE : 8/12/2010
 ALTERED BY : ashokkumar.alvce CHECKED BY : rchandran.alvce
 MED APPROVAL : sureshp.alvce APPROVED BY : sragarajan.alvce

DIGITALLY SIGNED. PHYSICAL SIGNATURE NOT REQUIRED

SNO	PART NO	DESCRIPTION	QTY
B 4	F2935015	NUT	1
B 3	F2901615	NIPPLE	1
B 2	F0154915	ADAPTOR	1
A 1	---	COLD DRAWN SEAMLESS CDS-1 ANNEALED STEEL TUBE 16 OD,2 THK TO IS 3074	1

BILL OF MATERIALS			
APPEARANCE ITEM	ER-DIN	DATE	
YES	NO	023273	19/05/06
FINISHED WEIGHT (APPROX)	REF. PT. No.	B2205401	
SCALE	S/A PT No.		
1:2	SUPERSEDES		
	SPEC NO.	ALSG19	

DRAWN/ DATE	CHECKED/ DATE	MED APPROVAL/ DATE	APPROVED/ DATE	STDS APP/ DATE
A.A 19/05/05	SN 19/05/05	PRAKASH SHAH 22/05/06	SN 19/05/05	---

MATERIAL SEE B.O.M

HEAT TREATMENT

REMARKS FOR STALLION MARK IV

DESCRIPTION STEERING PIPE-PRESSURE LINE

PART No. **B 2 2 3 8 2 1 3 B.0**

SHEET NO.1.....OF....1..... **A1**

UNLESS OTHERWISE SPECIFIED			
ASHOK	TOLERANCES	REFER IS:2102 : MEDIUM FOR MACHINING AND COARSE FOR FABRICATION	
LEYLAND	SURFACE PROTECTION	FABRICATED COMPONENTS TO BE DEGREASED, DESCALED. APPLY ZINC PHOSPHATE, APPLY EPOXY PRIMER AND APPLY BLACK ENAMEL TO MEET 300 HRS OF SALT SPRAY LIFE WHEN TESTED AS PER ASTM B117 (UNDER PELLICULAR CORROSION <= 2mm, NO BLISTERING IS ALLOWED.) MACHINED SURFACE TO BE APPLIED WITH RUST PREVENTIVE OIL TO IS:1154	
	SURFACE FINISH AS PER IS:3073 (CLA VALUE)	METRIC SCREW THREADS SHALL CONFORM TO THE LIMITS AND TOLERANCES SPECIFIED IN THE CURRENT IS:4218 CLASS 6g EXTERNAL OR 5H INTERNAL.	SHARP EDGES TO BE REMOVED DIMENSIONS ARE IN MM DO NOT SCALE DRAWING