

DETAIL E
SCALE 10:1
R.508⁰_{+0.508}
(4 PLCS)

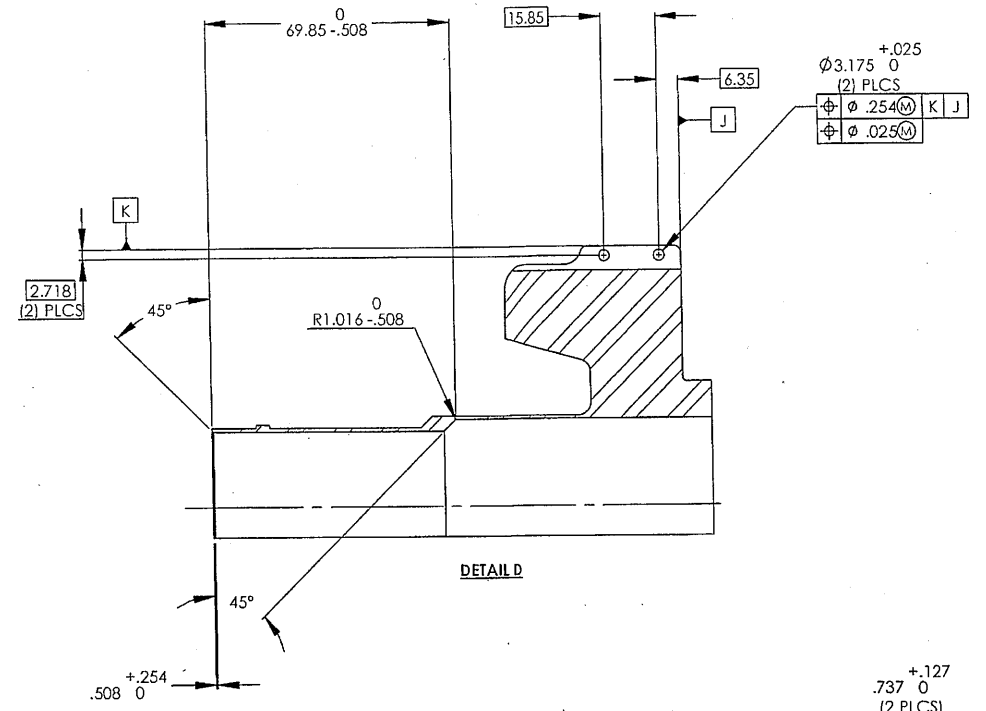

DETAIL D

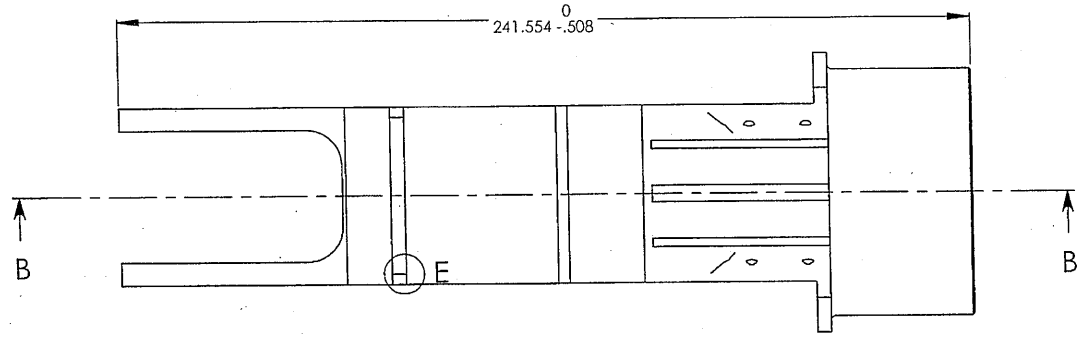
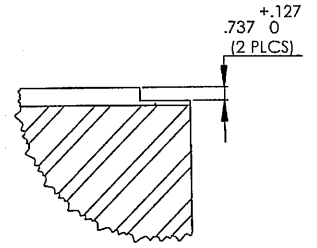

DETAIL F
SCALE 5:1

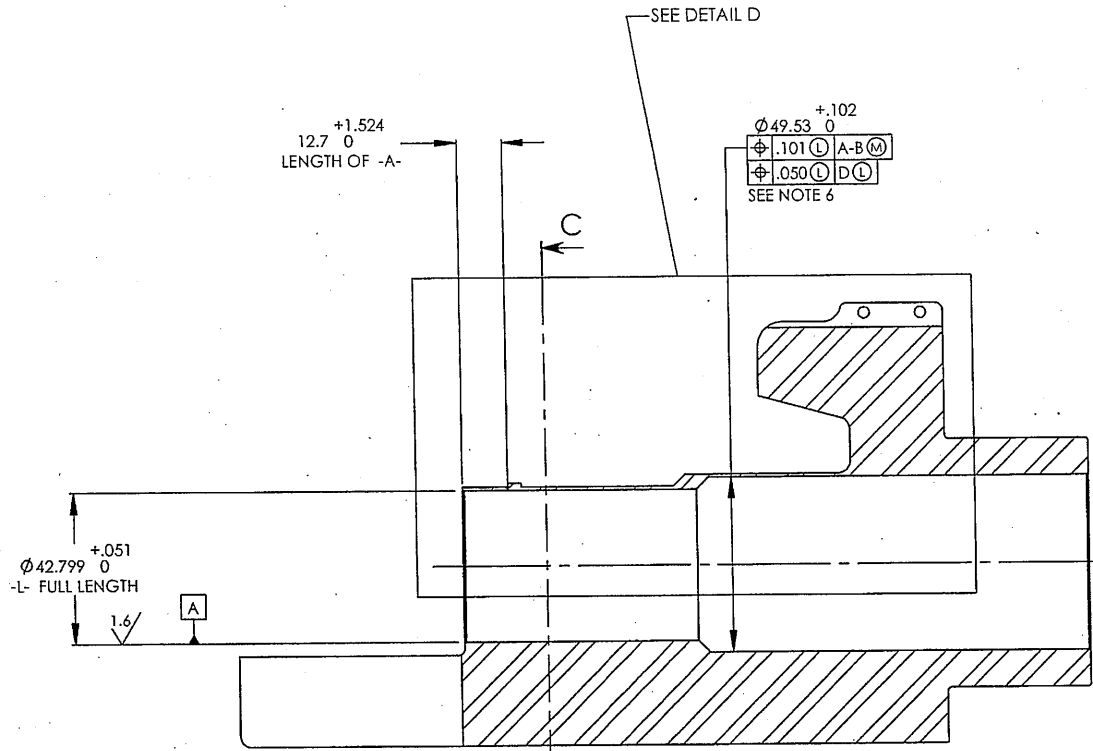

SECTION B-B

+12.065
2.921⁰_{+0.025} (2) PLCS
THIS DIM. MUST BE IDENTICAL
WITHIN 2.54 ON BOTH SIDES

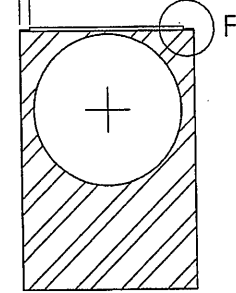

SECTION C-C

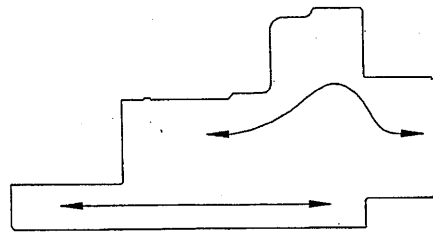

FORGING GRAIN FLOW DIAGRAM

UN CONTROLLED COPY
CERTIFIED CORRECT COPY OF APPROVED
DRAWINGS AT THIS DATE. 01-09-2022

DESIGN & DRAWING OFFICE,
ORDNANCE FACTORY, TIRUCHIRAPPALI - 620 016.

[Signature]
PROJECT OFFICER
HOS/PS6

Material: Steel, ASTM A108 or A322, 4140, 4145 or 4150		DWG Details		SUB: BLOCK, TRUNNION, BLANK	
Alt. Material:	DRAWN	SIGN	DATE	FOR: BLOCK, TRUNNION	Do not scale Drawing
Hardness:	CHECKED			PROJ.: SRCG	All Dimensions are in mm
Finish:	HOS/D&DO Div. Officer Prodn			Design Ref 6528264	
Un tolerated dimensions IS:2102 Medium	Div. Officer QC			DWG. No.: TEND-2672	A3 QPG -
	Div. Officer DDO			ORDNANCE FACTORY TIRUCHIRAPPALI-16.	Wt. (Appx) gm SHEET: 2 OF 2