

4

3

2

1

D

C

B

A

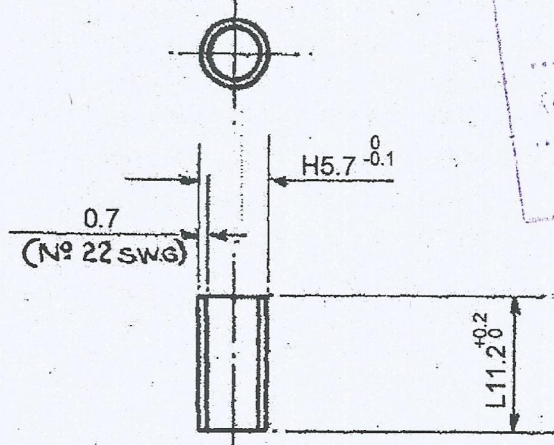

STANDARD
 Jt. Works Manager
 Certified as correct copy
 of drg. on

IF THIS COMPONENT IS FORMED FROM SHEET
 GAP NOT EXCEEDING 0.5 IS ACCEPTABLE.

TRIM ON THIS LINE WHEN SUPPLIED TO TRADE

03-09-13		APPROVED		DGNAI	
R.No	DATE	ZONE	BRIEF RECORD		AUTHORITY INITIALS
SCALE:- NTS		TOL.	DIMENSIONS ARE IN mm		ASSY DRG No:- NAD 7606
DGN	DRN	TCD	COMP	CHD	ASSY DRG LIST.
PASSED	CTO(D)	APPD.	GEN SPEC :- NA-SPEC A-31B		DTE GEN OF NAVAL ARMAMENT INSPECTION IHQ,MOD (NAVY) N. DELHI
MATL:- BRASS		STORE SPEC :-			
MATL SPEC:- STA 7 Cz 4 or Cz 5 OR IS : 2501-1963 OR BS : 2871-1957, Cz 105 378-1963, 855-1963 or 267-1963		STORE REF No.			
PROTECTIVE FINISH:-		GAUGE SCH No.			
			D.S. CAT No.		
<h1>SLEEVE</h1>					
					DRG No. NAD 7606/7

A-4

USED ON: STRIKER MECHANISM, N8 MK1

BASED ON:- NOD 8026/7 Dt. 18.11.57