

Ritningsändring - G H J K L
 Produktförändring F - - - -

(D)

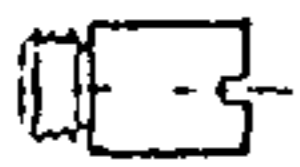
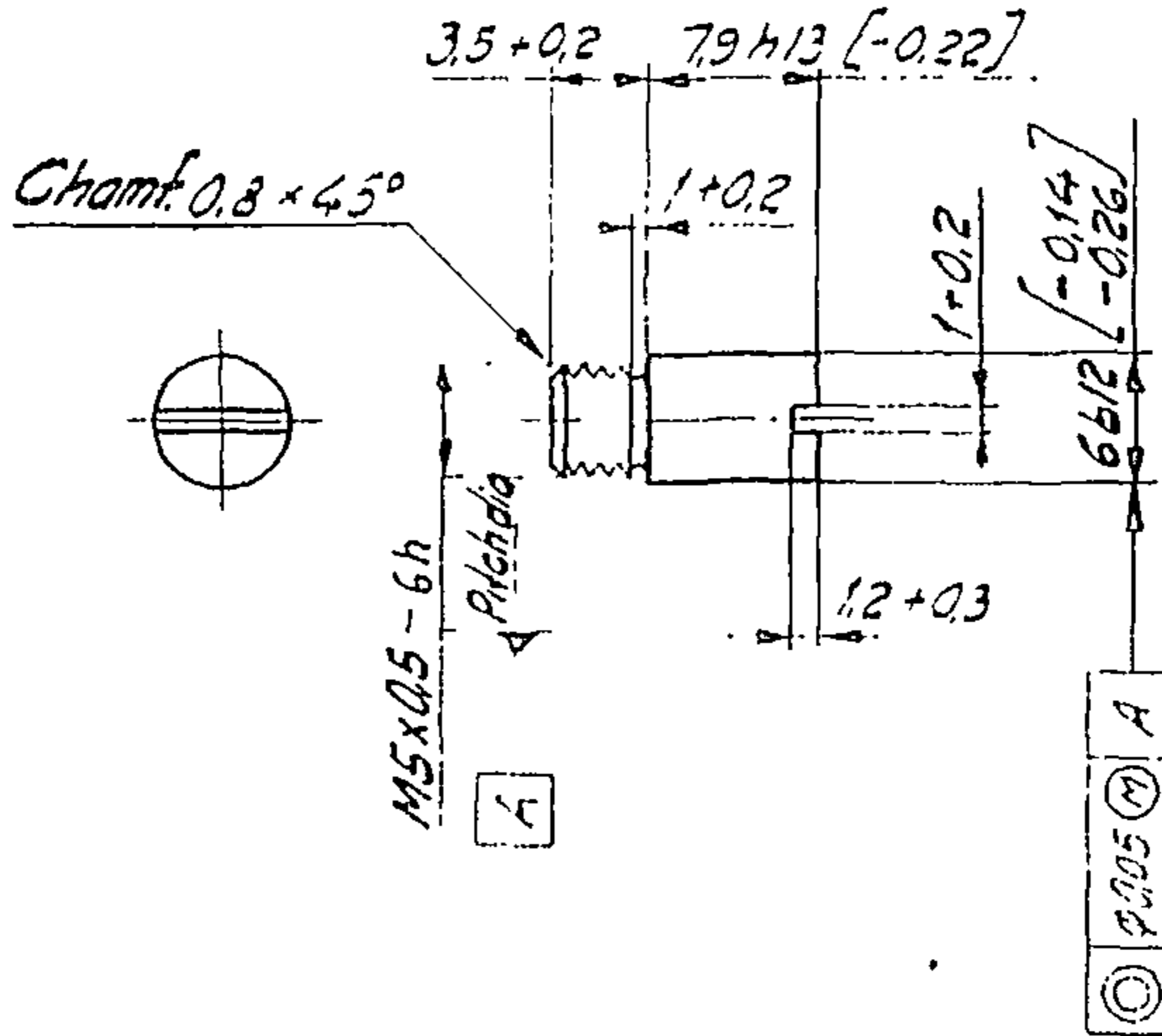

| | | | |
|-------------------------|-----|-----|---------|
| (2) D.C.:- 2750 -I(P):- | | | |
| DRG. No. AMENDED. | | | 6.12.11 |
| D.C.:- 2423 -I(P) | | | 18.7.07 |
| DRG. PROV. SEALED | | | |
| AMENDMENTS | CHP | SKG | DATE |

Scale 1:1

ANTAL PRODUKT 1
 MATERIALKVALITET Steel SS 1914 alt. EN 10087-1.0721
 VÄRMEBEHANDLING Hardened: Surface hardness min 700HV1. Hardness depth DC max 0,2
 YTBEKÄFFENHET 6.3
 YTBEHANDLING Manganese phosphated and oiled to Gf 1.003.064
 GRADNING ENL. FFV 66
 LAGESMÅTT To SS-150 1101
 MARKNING:
 TEKN. BESTÄMMELSER see above

| | | | | | | |
|----------------|----------|---------|------|----|---------------------|-------|
| Årad 37 | Gransk | Kop. IT | 15 2 | 18 | Vyplacering m. foto | Skala |
| Datum 19.10.62 | Stand nr | 17 | 18 | 19 | erutaperisk | 2:1 |
| | | | | | Erstatler | |

PRODUKT Acc.f. 84mm RCL M2 Telescopic Sight 230144
 NAMN Screw, slide

FORSVARETS FABRIKSVERK
 CARL GUSTAFS STADS GEVÄRSFAKTORI CQA(1)-792/27

DRG. VETTED BY SOD...
 D.C.:- 2423-I(P), 2750-IC(P)

A 4