

DRAWING NO.  
172.40.300/F

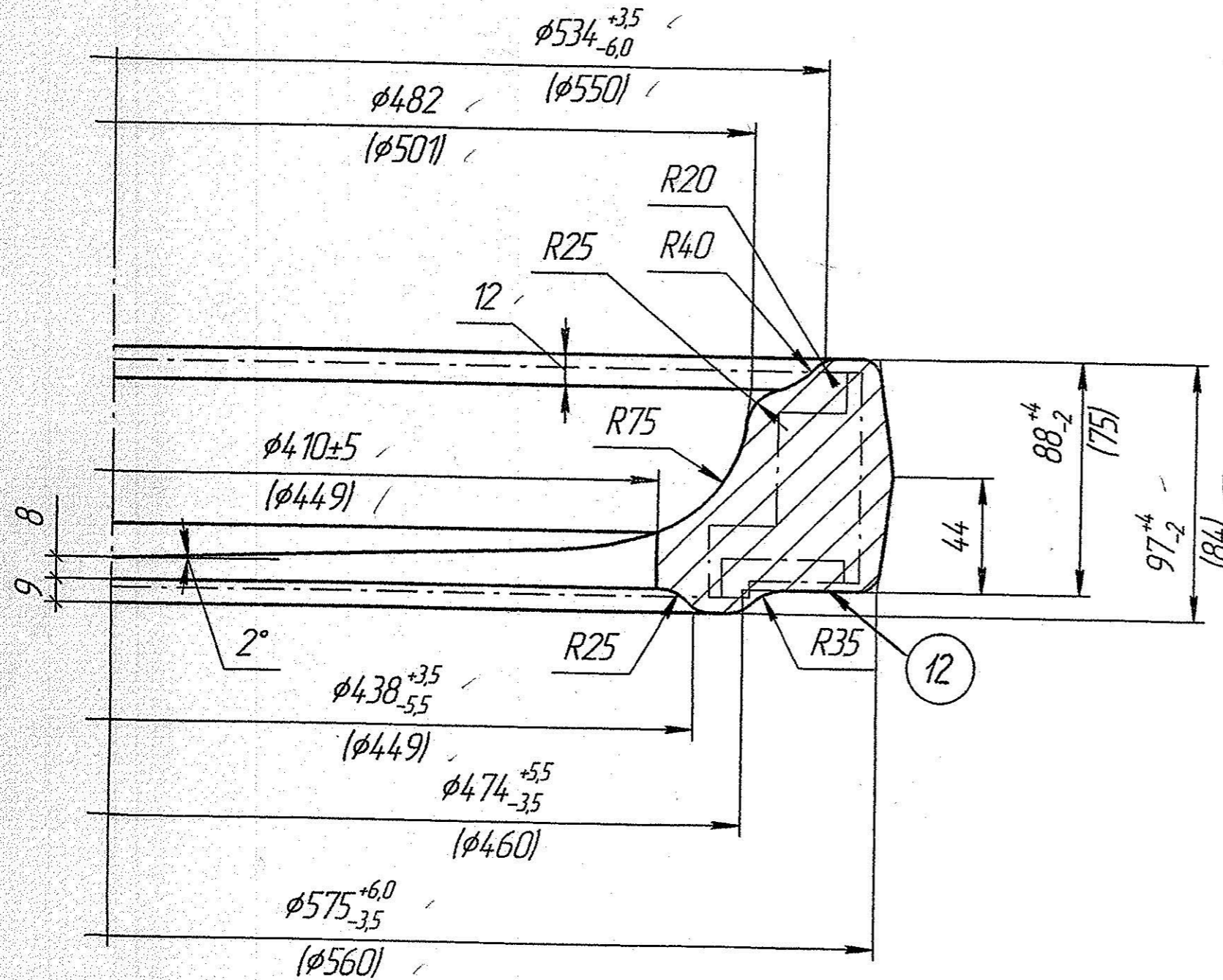

### TECHNICAL REQUIREMENTS

01. 215...268 HB.
02. OUTER STAMPING DRAFTS -  $7^\circ$
03. UNSPECIFIED RADII - R10.
04. SURFACE DEFECTS AND DEPRESSIONS DUE TO SCALES MAY BE IN DEPTH UPTO 0.5 OF ACTUAL MACHINING ALLOWANCE.
05. SHIFT - UPTO 2.5 MM.
06. PROJECTION DUE TO DEBURRING ALONG THE PARTING LINE OF DIES MAY BE UPTO 2.5 MM.
07. PROJECTION DUE TO DEBURRING MAY BE UPTO 2.5 MM.
08. CONTINUOUS BURR MAY BE ALLOWED IN HOLE.
09. WARPAGE - UPTO 2.0 MM.
10. MISALIGNMENT OF BROACHED HOLE MAY BE UPTO 3.5 MM.
11. DIMENSIONS GIVEN IN BRACKETS ARE FOR MACHINING
12. MARK CODE NUMBER OF SHOP IN-CHARGE.
13. DE-SCALES (SHOT BLASTING)
14. PAINT RED OXIDE

T 90

MATERIAL	FORGING WT.	
30XGCA GOST 4543-71	81 KGS	
ALT. MATERIAL	HAMMER	SCALE
	EK-32	NTS
DRAWN	CHECKED	APPROVED
<i>L. Ruffon</i> 01/09/03	<i>M. S.</i> 01/09/03	<i>S. R.</i> 01/09/03
DRAWING NO.	172.40.300/F	
NOMENCLATURE:	RH DRUM	
<b>HEAVY VEHICLES FACTORY</b> AVADI, CHENNAI		