

2:1 ENLARGED VIEW
AT SECTION-BB

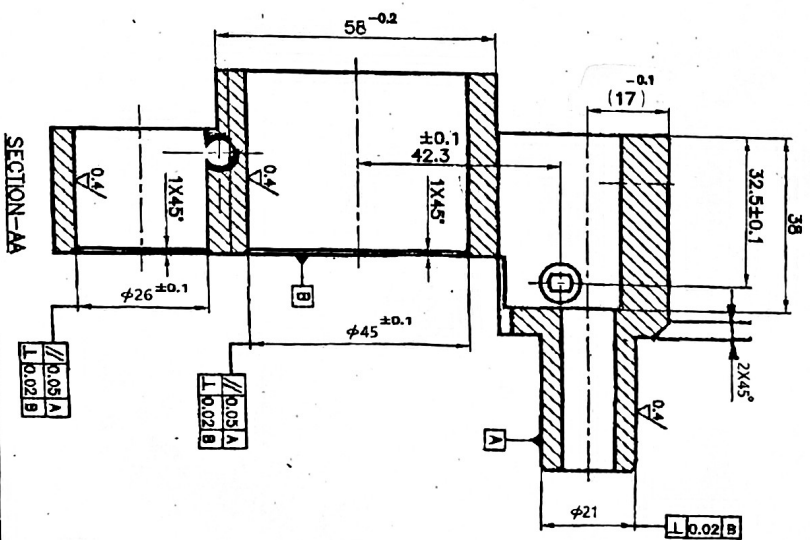
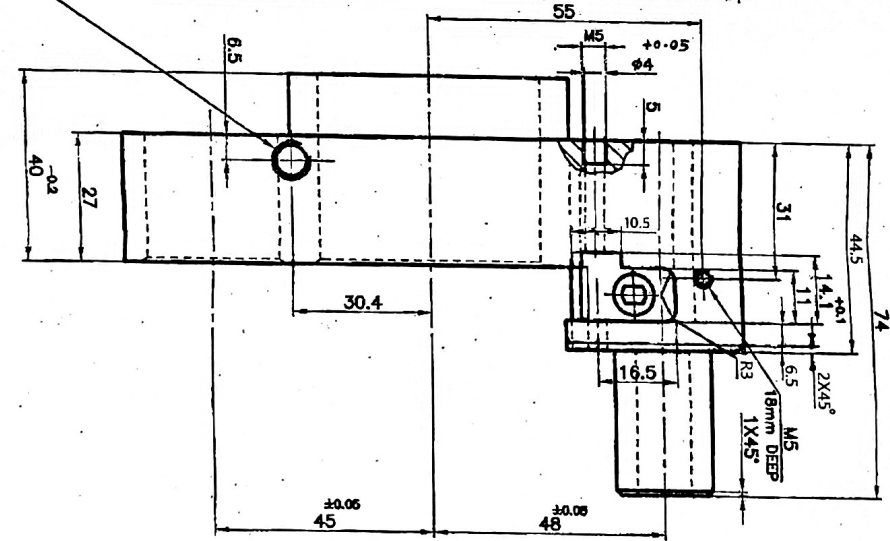
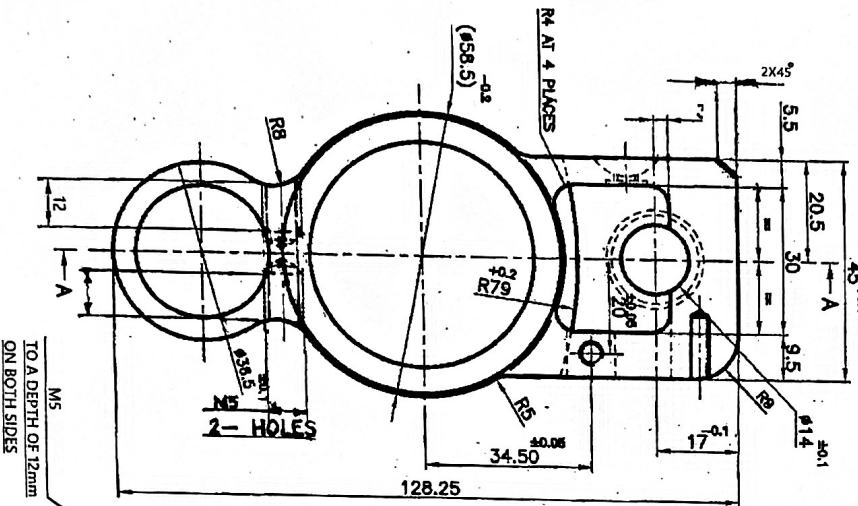
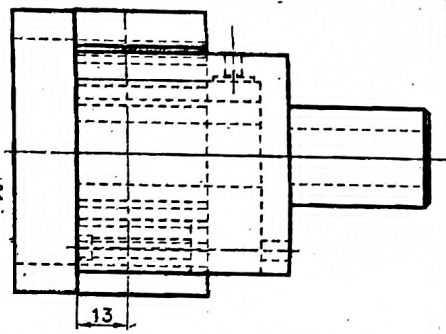

MANUFACTURER GET THE APPROVAL
OF SAMPLE SUPPLIED BEFORE BULK
PRODUCTION.

UN CONTROLLED COPY
CERTIFIED CORRECT COPY OF APPROVED
DRAWINGS AT THIS DATE 15/06/21
DESIGN & DRAWING OFFICE
ORDNANCE FACTORY TRICHIRAPPALLI-500 016

1. DIMENSIONS ARE IN mm.
2. UNTOLERATED DIMNS. AS PER IS : 2102 (MED)
3. SHARP CORNERS SHOULD BE BLUNT TO R 0.5

MATERIAL : AL - 7075 WITH T6 CONDITION

DIMENSIONS GIVEN ARE SUITABLE FOR
FURTHER MACHINING AND H.A. COATING

HOS/PS2

NO.	REV.	DATE	DESCRIPTION
1			ISSUED FOR PRODUCTION

CHECKED	DATE	BY
DRAWN	DATE	BY
DESIGNED	DATE	BY
APPROVED	DATE	BY

PART NO.	DESCRIPTION	NO. OF	MATERIAL	TREATMENT	REMARKS
	HOUSING LAUNCHER				
THICKED	DATE	BY			
DRAWN	DATE	BY			
CHECKED	DATE	BY			
DESIGNED	DATE	BY			
APPROVED	DATE	BY			

DESIGN NO.	33P 1104
DRW. NO.	TEND - 2661
SCALE	N.T.S
OPERATION NO.	
SHEETS	1
SHEET NO.	1

ORDNANCE FACTORY	TRICHIRAPPALLI-16.
------------------	--------------------