

DRG. INDIANISED BASED ON RUSSIAN ORIGINAL ISSUE -NIL

DRAWING NUMBER  
**172.33.817**

SHEET No. 1 OF 1

Rz80/ (✓) (✓)

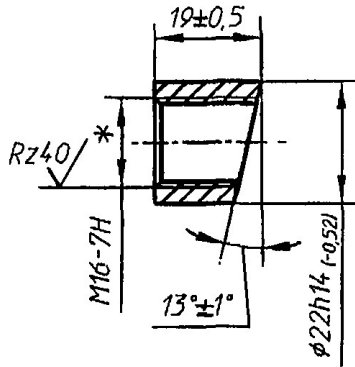

1. Материал - заменитель алю. сплав АМз5 ГОСТ 4784-97.
2. \* Шероховатость обеспечить инструментом.
3. Остальные требования по 520.ТУ1

1. Alternate - Material aluminium alloy AMz5 GOST 4784 - 97.
2. \* Surface finishing to be ensured by tool.
3. Other requirements by 520.TY1.

**356**

SUPPLY CODE

U-01-1-4

D 90209

F-103  
48

PILOT SAMPLE SHOULD BE APPROVED BY A H S P BEFORE BULK PRODUCTION.

		EST. WT. (Kg) 0.008	TO BE STAMPED OR MARKED WHERE INDICATED THUS # ( LETTERS)
		ALL SHARP EDGES AND CORNERS TO BE REMOVED UNLESS OTHERWISE STATED MACHINED CORNERS TO HAVE R OUT-SIDE R INSIDE EQUIVALENT CHAMFERS ARE PERMISSIBLE.	
		MATERIAL :- Aluminium alloy AMz6 GOST 4784 - 97	USED ON :- 172.33.278cbCb
ISSUE	DATE	NATURE OF AMENDMENTS	
DRN	<i>(Signature)</i>	SCALE :- 1 : 1	CONTROLLERATE OF QUALITY ASSURANCE (HEAVY VEHICLES) AVADI
CHD	<i>(Signature)</i>	DIMENSIONS IN mm	
APPD	<i>Chanchal</i>	TOLERANCE ON DIMENSIONS UNLESS OTHERWISE STATED IS : 2102 - 69	TITLE :- <b>BOSS</b>
DATE	10.9.04	ALL THREADS TO CONFORM TO	D S' CAT NUMBER
		DRAWING NUMBER <b>172.33.817</b>	

SIZE A4