

L/OUT No.

# FACE MASK, GOGGLES N.V.P. 102 A.

DRG. No  
IRDE-2016/13

## PLUNGER, DETENT

THIRD ANGLE PROJECTION

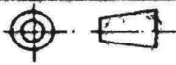

MCT-1868

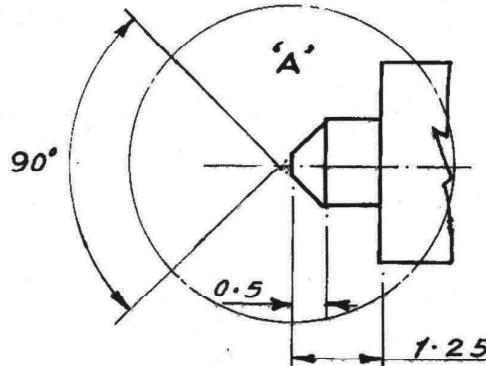

**ENLARGED VIEW AT 'A'**  
SCALE: 10:1

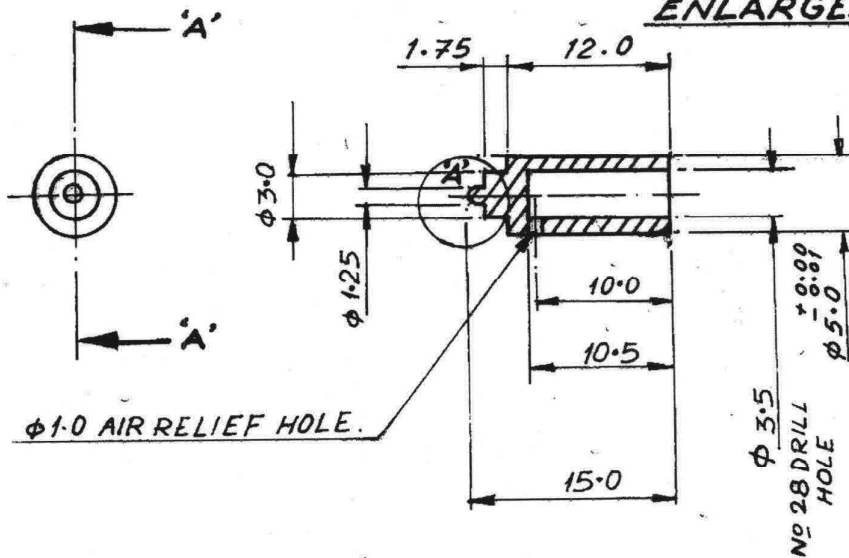

FOR TRADE USE  
Date of Issue 11/26/24.  
Rajeev

(a) MATL. STEEL IS: 7283, 1973.  
FINISH:- HARD CHROME PLATED

DIMENSIONS ARE IN M/M.  
IMPORTANT DIMENSIONS MARKED THUS ⊕  
INFORMATION MARKED THUS † TO BE MARKED ON

	DR- <i>Quar</i>	DATE- 15/11/24	SCALE- 2:1
	TR-	MATL. AS ABOVE	TREAT. AS ABOVE
	CH-	SHEETS 1	SHT. No. 1
(a) DA. No. 10/2015 DT. 27.1.2015	APPROVED		DRAWING No.
AMENDMENTS	<i>Quar</i> JMM/D.O.	N.K. Vijra AWM/TS	MCT-1868/1
OFD/DO/002			

ORDNANCE FACTORY, DEHRADUN

ORDNANCE FACTORY, DEHRADUN.

L/OUT No.

FACE MASK, GOGGLES N.V.P. 102 A.  
SPRING, HELICAL, COMPRESSION

DRG. No  
IRDE-2016/12

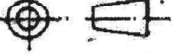
THIRD ANGLE PROJECTION 

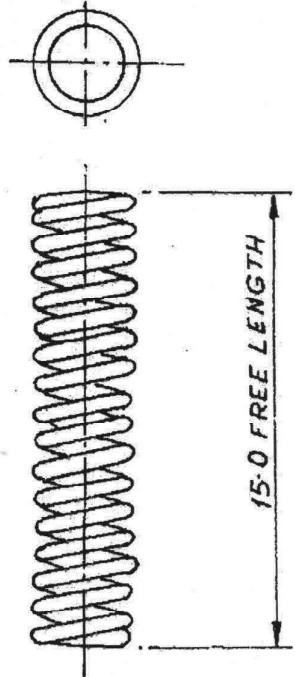

- OUT SIDE  $\phi$  --- 3.2
- WIRE  $\phi$  --- 0.56
- DEFLECTION PER COIL --- 0.155
- LOAD --- 0.85 KG.
- No. OF EFFECTIVE COIL --- 15
- ENDS SQUARED BY GRINDING

FOR TRADE COPY  
Date of Issue: 11/06/2015

MATL:- SPRING STEEL IS: 727 Gd-3/15: 9680-1980  
REAFFIRMED 1989.  
TREAT:- HEAT TREATED

DIMENSIONS ARE IN M/M.  
IMPORTANT DIMENSIONS MARKED THUS  $\odot$   
INFORMATION MARKED THUS  $\dagger$  TO BE MARKED ON.

		DATE- 10/27/2015	SCALE- 5:1
	DR- <i>shw</i>	MATL.	TREAT.
	TR-	AS ABOVE	AS ABOVE
	CH-	SHEETS 1	SMT. No. 1
<del>ISDA No 10/2015 DT. 27.1.2015</del>		APPROVED	
AMENDMENTS		DRAWING No.	
OFD/DO/002		MCT-1867/A	
		<i>Awmts</i> JMM/O. O.	N. K. Vij AWMTS

ORDNANCE FACTORY, DEHRADUN

L/OUT No.

FACE MASK, GOGGLES N.V.P. 102 A.

SPECIAL SCREW

DRG. No  
IRDE - 2016/14

THIRD ANGLE PROJECTION

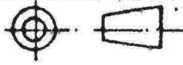

MCT-1863

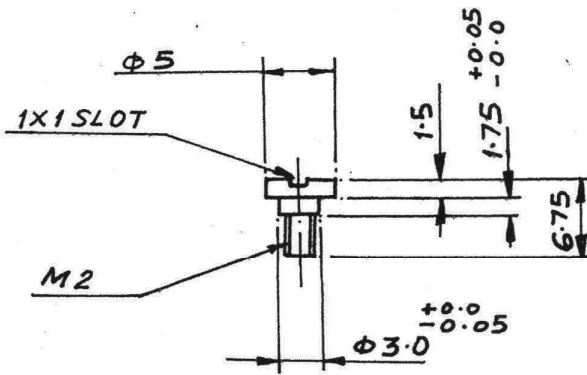
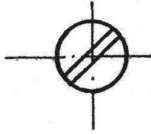

Date of Issue 11/26/17 *Revised*

MATL. STEEL IS: 1570 C-10  
FINISH:- BLACK NICKLE PLATED.

DIMENSIONS ARE IN M/M.  
IMPORTANT DIMENSIONS MARKED THUS ∅  
INFORMATION MARKED THUS † TO BE MARKED ON

	DR- <i>Leena</i>	DATE-25 <sup>th</sup> / <sub>2K</sub>	SCALE- 2:1
	TR-	MATL. AS ABOVE	TREAT. AS ABOVE
	CH-	SHEETS 1	SHT. No. 1
AMENDMENTS	APPROVED		DRAWING No.
OFD/DO/002	<i>Jain</i> JAIN D. O.	N.K. Vijan AWM/TS	MCT-1863





ORDNANCE FACTORY, DEHRADUN

L/QUI No

**FACE MASK, GOGGLES N.V.P. 102 A.**

DRG. No  
IRDE-2027/4

**BEARING, BRIDGE (OUTER) (a)**

THIRD ANGLE PROJECTION

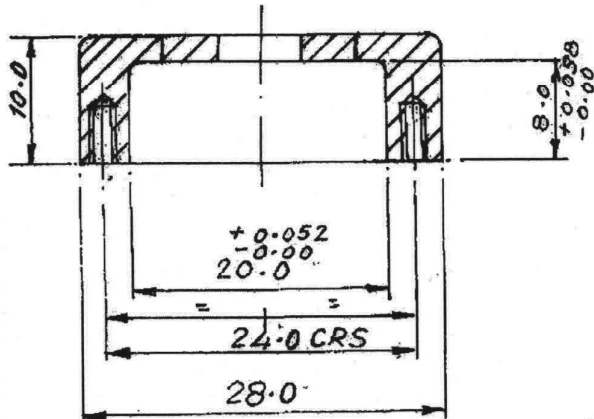
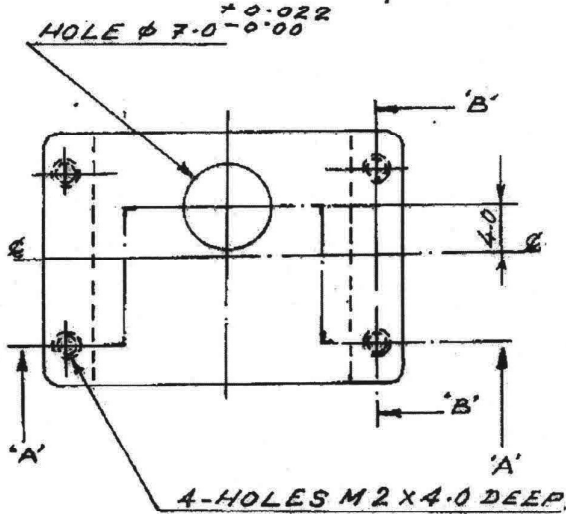

SECTION AT 'A-A'

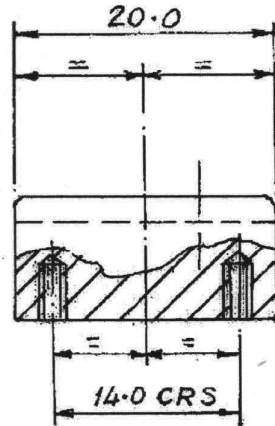

PART SECTION AT 'B-B'

MATL: AL ALLOY IS: 753/64630  
& SPECN: (HE-50) W/P

FINISH:- ANODISED DYED  
DULL BLACK.

DIMENSIONS ARE IN M/M.  
IMPORTANT DIMENSIONS MARKED THUS  $\oplus$   
INFORMATION MARKED THUS  $\dagger$  TO BE MARKED ON

	DR- <i>2/2015</i>	DATE-30/11/15	SCALE: 2:1
	TR-	MATL. AS ABOVE	TREAT. AS ABOVE
	CH-	SHEETS 1	SHT. No. 1
(a) D.A. No 10/2015 DT. 27.1.2015	APPROVED		DRAWING No.
AMENDMENTS	<i>Jawal</i>	N.K. Vijaya	MCT-1873/1
OFD/DO/002	Jawal D. O.	AWH/TS	

FOR TRADE MARK  
Date of Issue - 11/06/15  
*Rupin*

ORDNANCE FACTORY, DEHRADUN

L/OUT No.

FACE MASK, GOGGLES N. V. P. 102 A.

SPECIAL SCREW

DRG. No  
IRDE-2016/28

THIRD ANGLE PROJECTION 

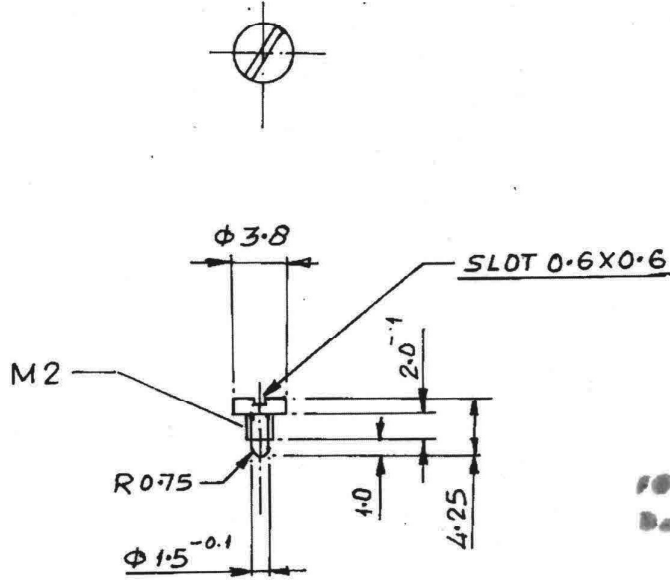

FOR TRADE COPY  
Date of Issue 11/06/21  
*[Signature]*

(a)  
MATL. STEEL IS: 7283-1974.  
FINISH:- BLACK CHROME PLATED

DIMENSIONS ARE IN M/M.  
IMPORTANT DIMENSIONS MARKED THUS ⊕  
INFORMATION MARKED THUS † TO BE MARKED ON

	DR- <i>[Signature]</i>	DATE- 18/11/21	SCALE- 2:1
	TR-	MATL. AS ABOVE	TREAT. AS ABOVE
	CH-	SHEETS 1	SHT. No. 1
(a) D.A.No. 10/2015 DT. 27-1-2015	APPROVED		DRAWING No.
AMENDMENTS	<i>[Signature]</i>	N. K. V. V. V.	MCT-1862/1
OFD/DO/002	JMM/D. O.	AWM/TS	

ORDNANCE FACTORY, DEHRADUN

L/OUT No.

# FACE MASK, GOGGLES N. V. P. 102 A.

DRG. No.  
IRDE-2027/2

## SLIDE, MALE

TITLE OF

OPERATION

THIRD ANGLE PROJECTION 

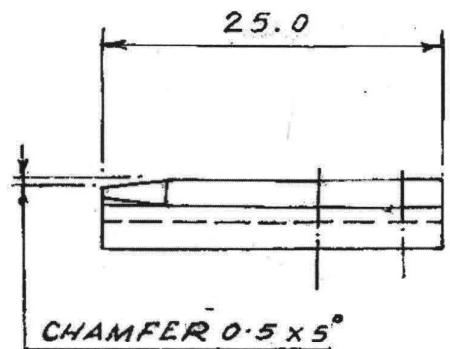
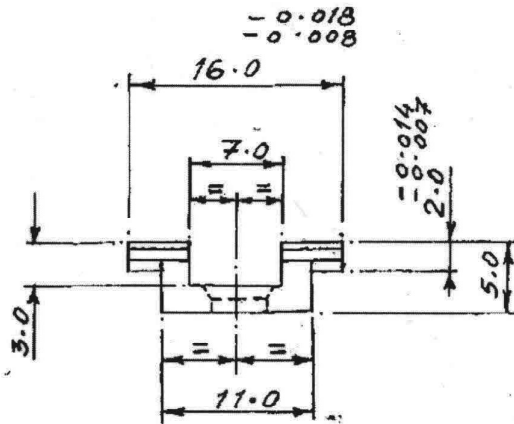
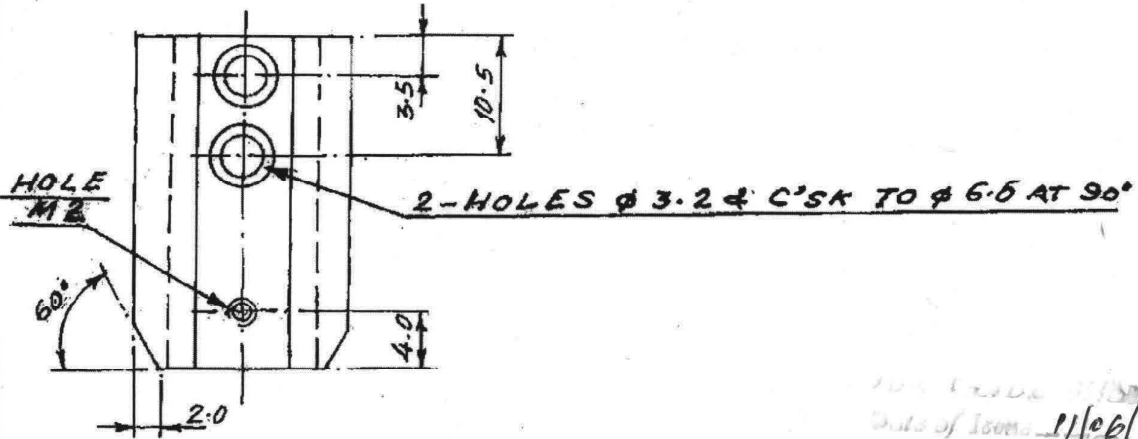

*11/06/15*  
*Qnts of Issue*

MATL. :- STEEL, IS:5517-1978 Gde. C-40 OR IS:7283-1974.

DIMENSIONS ARE IN M/M.  
IMPORTANT DIMENSIONS MARKED THUS ⊕  
INFORMATION MARKED THUS † TO BE MARKED ON.

		DATE-19 <sup>11</sup> / <sub>2K</sub>	SCALE:-2:1
DR- <i>Quinted</i>		MATL. AS ABOVE	TREAT BLACK NICKEL PLATED
TR-		SHEETS 1	SHT. No. 1
CH-		APPROVED	
(a) D.A.No. 10/2015, DATE. 27.1.2015		DRAWING No.	
AMENDMENTS		MCT-1869A	
OFD/DO/002		N.K. Vijan AW TS	

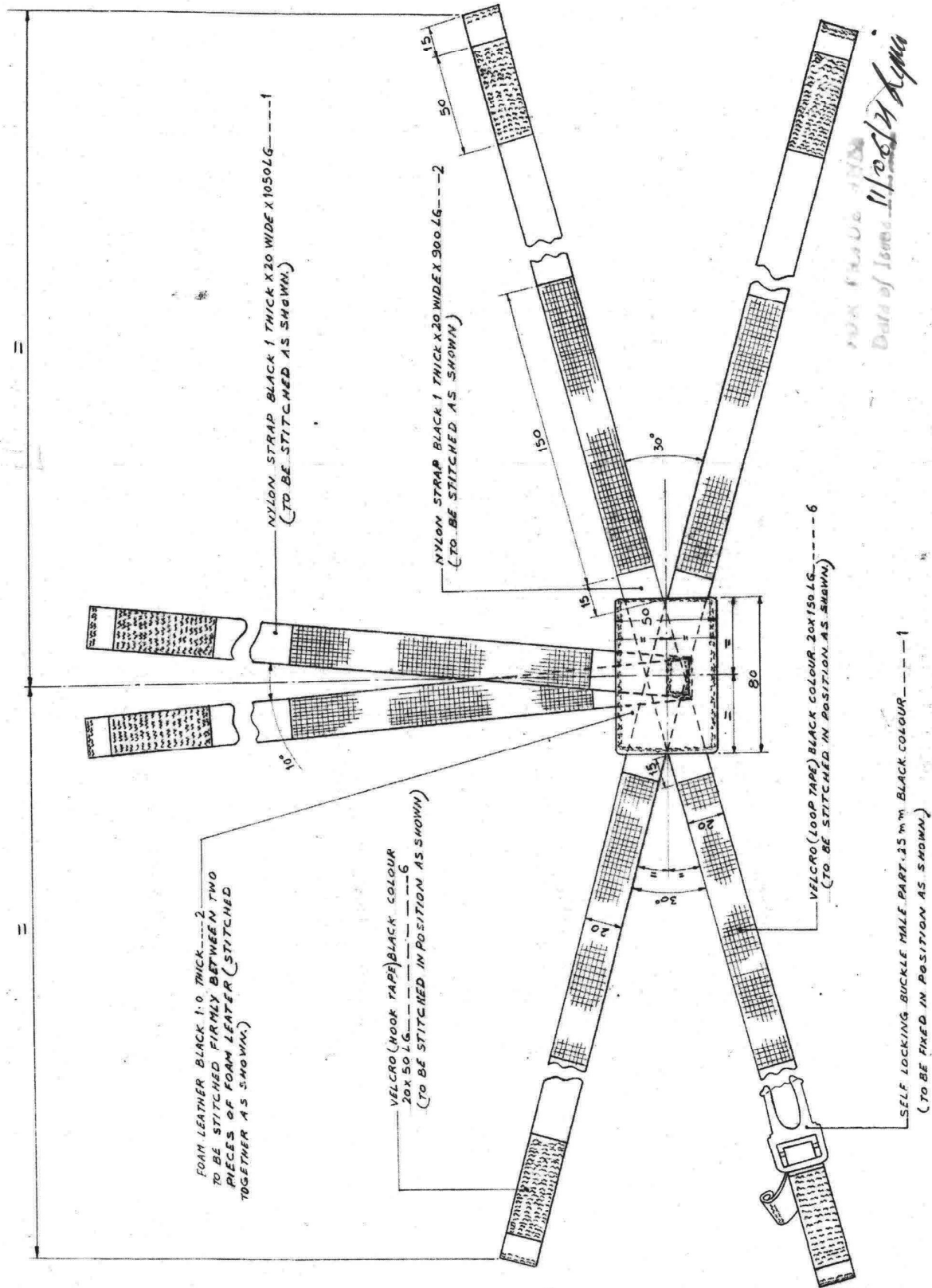

DI 6-10-93	SCALE: 1:1
MATE AS ABOVE	TREAT AS ABOVE
SHT 3	SHT. NO. 3
DRG. NO. MCT/1337/1	
AMENDMENTS	
(A D.A. NO. 10015 DT. 27/01/2015)	

FACE MASK GOGGLES NIGHT VISION PASSIVE, 102A  
STRAP, RETAINING

DR: <i>[Signature]</i>	DGM/PL
TR: <i>[Signature]</i>	
CH: <i>[Signature]</i>	APPROVED
1/CD-0	

ORDNANCE FY  
DEHRA DUN

DRG. NO. 102A 2027/7

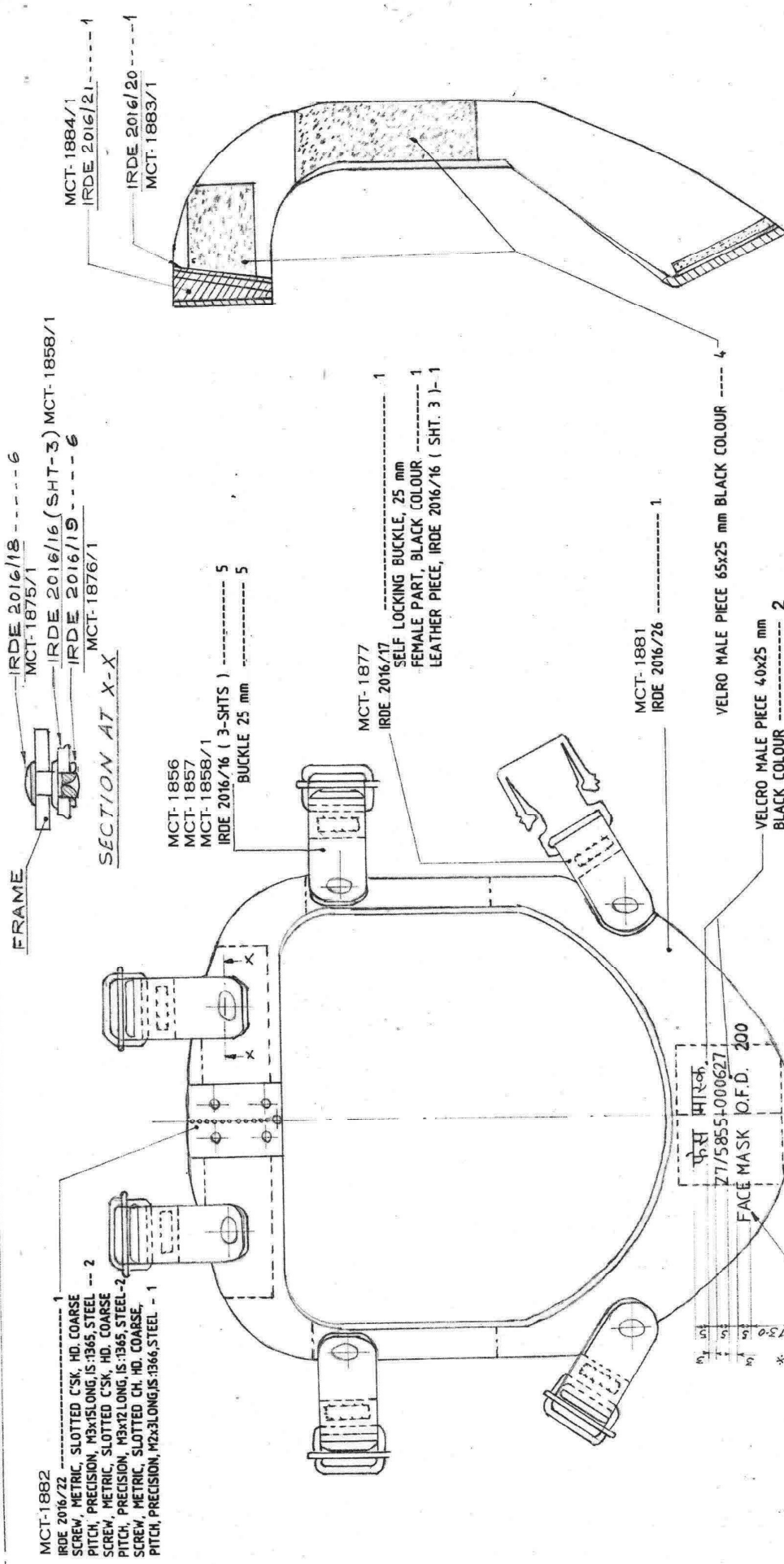

FOR TRADE MARK  
Date of Issue: 11/06/2004

NOTE:- ALL VELCRO MALE PIECES TO BE GLUED  
WITH ARALDITE IN POSITION AS SHOWN.

ORD. FY. D. DUN	DR. Y.M.M.	CH. <i>[Signature]</i>	DATE:- 6-10-93	SCALE:-
	TR.	CH.	MATL. AS ABOVE	TREAT. AS ABOVE
	APPROVED		SHEETS 3	SHT. No. 2
	<i>[Signature]</i> 1/COO.	D.G.M./PL	DRG. No. MCT/1337/1	
FACE MASK for GOGGLES N.V. PASSIVE 102A. ASSY. FRAME			AMENDMENTS	
			D.A. No. 56/004 Dt. 07-X-2004	
			O.F.D./D.0/002	

ORDNANCE FACTORY, DEHRADUN

L/OUT No.

FACE MASK, GOGGLES N. V.P. 102 A

DRG. No

RIVET, SPECIAL (a)

IRDE-2016/18

THIRD ANGLE PROJECTION

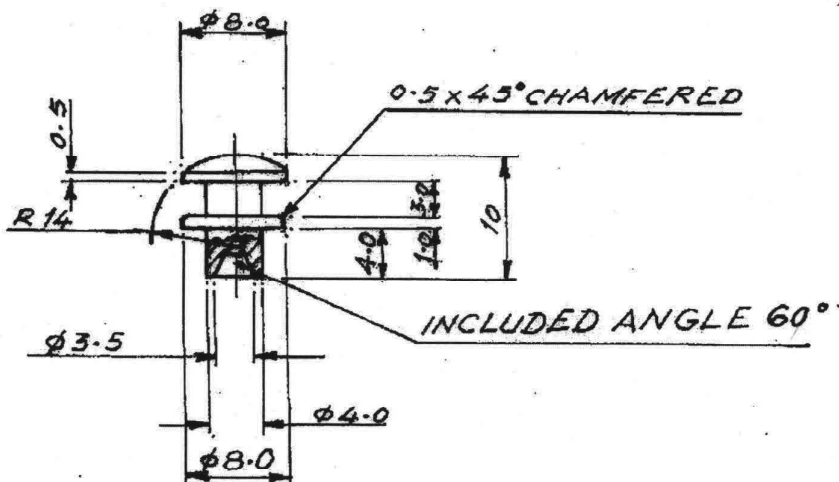
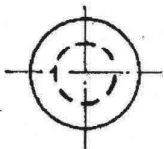
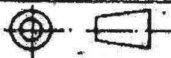

FOR TRADE OFF  
Date of Issue - 11/06/21  
Bipin

(a) MATL - ALUMINIUM ALLOY IS : 733:1983 III REVISION

66430-NP

FINISH - ANODISED DYED DULL BLACK.

DIMENSIONS ARE IN M/M.  
IMPORTANT DIMENSIONS MARKED THUS ⊕  
INFORMATION MARKED THUS † TO BE MARKED ON.

	DR- <u>Rupesh</u>	DATE-30/11/21	SCALE- 2:1
	TR-	MATL.	TREAT.
	CH-	AS ABOVE	AS ABOVE
(a) D.A.No. 10/2015 DT. 27-1-15	<p style="text-align: center;">APPROVED</p> <p style="text-align: center;">               N.K. Vijaya              AWM/TS           </p>	SHEETS 1	SHT. No. 1
AMENDMENTS		DRAWING No.	
OFD/DO/002		MCT-1875A	

ORDNANCE FACTORY, DEHRADUN

L/OUT No.

FACE MASK, GOGGLES N.V.P. 102A

DRG. No  
IRDE- 2016/19

WASHER FLAT (a)

THIRD ANGLE PROJECTION

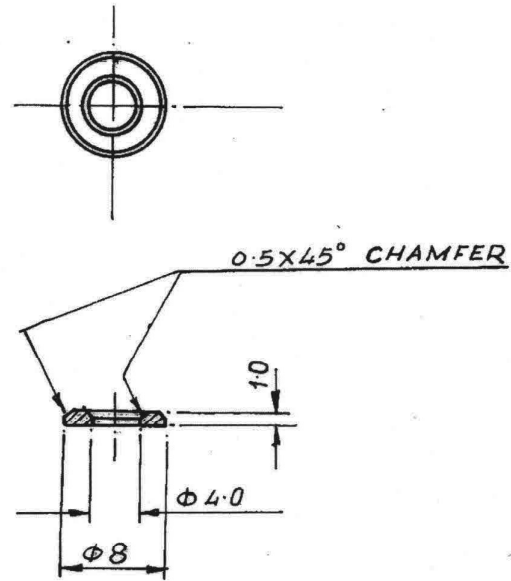
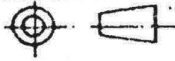

FOR TRADE USE  
Date of Issue 11/06/15  
*[Signature]*

(a)  
MATERIAL ALLOY IS: 733-1983 III REVISION  
64430-WP.  
FINISH: ANODISED DYED DULL BLACK

DIMENSIONS ARE IN M/M.  
IMPORTANT DIMENSIONS MARKED THUS ⊕  
INFORMATION MARKED THUS † TO BE MARKED ON

	DR- <i>Rokesh</i>	DATE-	SCALE - 2:1
	TR-	MATL.	TREAT.
	CH-	AS ABOVE	AS ABOVE
(a) D.A.No. 10/2015 DT. 27.1.2015	APPROVED		SHEETS 1
AMENDMENTS	<i>[Signature]</i> N.K. Vijra AWM/TS	DRAWING No	
OFD/DO/002		MCT-1876A	