

3-3

Γ

REDUCED ORIGINAL No. -1
RH CYLINDER HEAD

1. NICKS, MARKS FLAY MARKS AND DIG OUT FROM MACHINING ARE NOT ALLOWED ON THE SURFACE M3.
2. SURFACE M₂ AND M₃ SHOULD BE ON ONE FLATNESS.
3. *4 BASE AXIS OF NEAR DIAMETER.
3. OTHER GRAPHICS, DIMENSIONS, SURFACE FINISH MATERIAL AND TECHNICAL REQUIREMENTS ARE AS PER DRAWING 306-16-23.

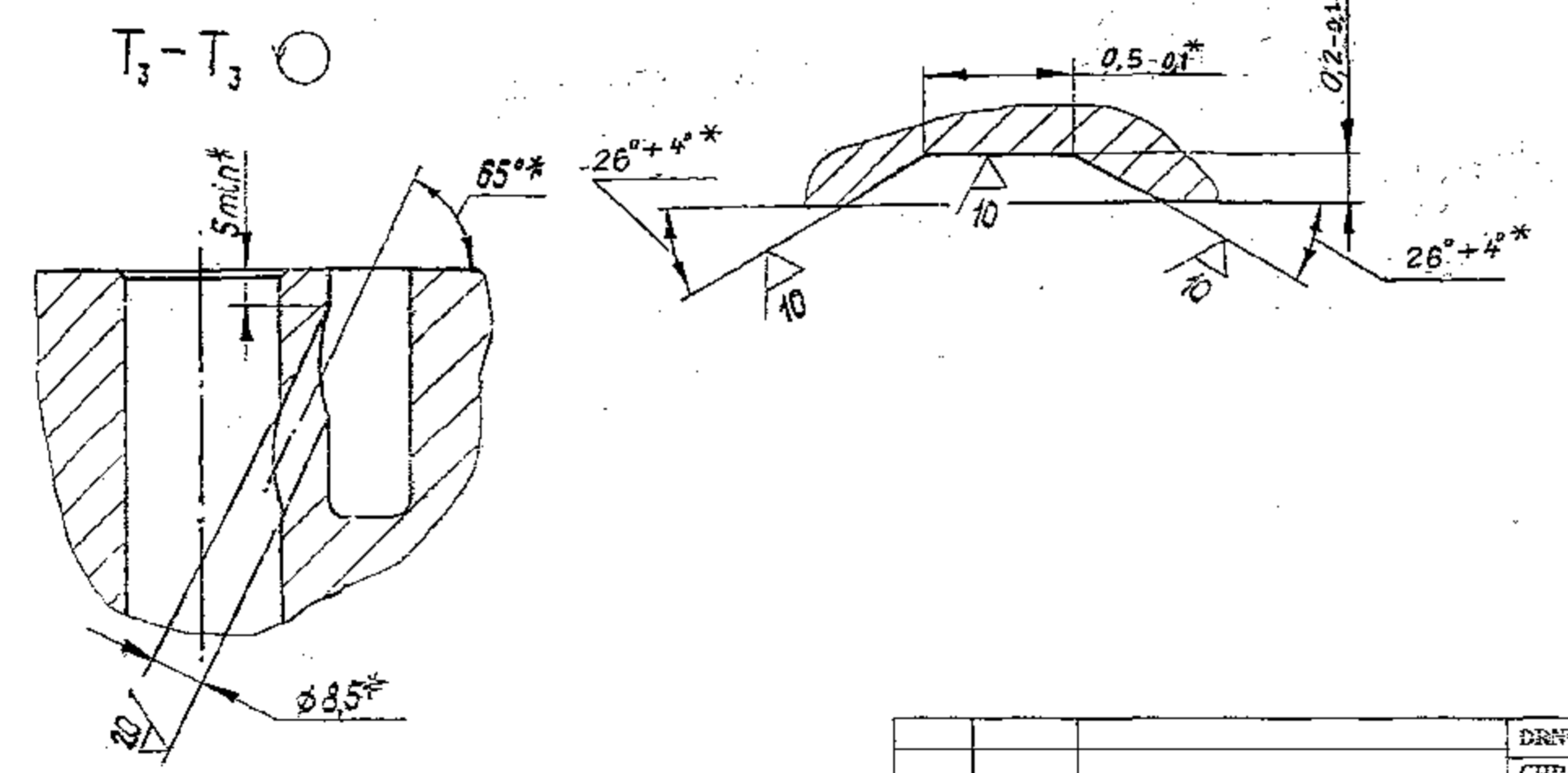
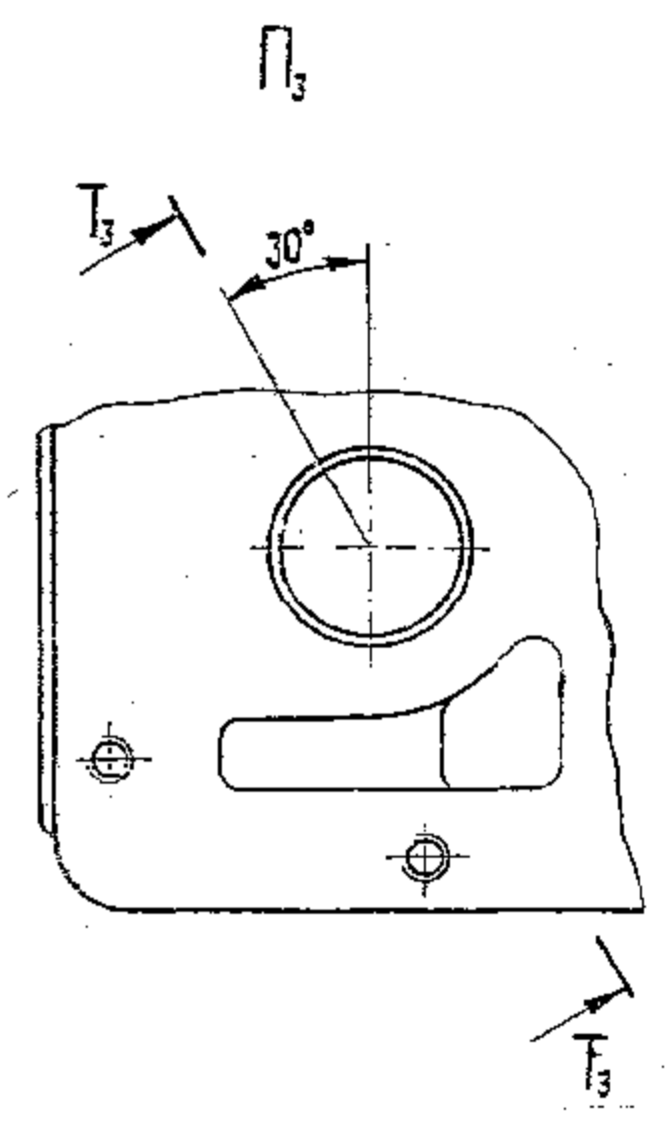
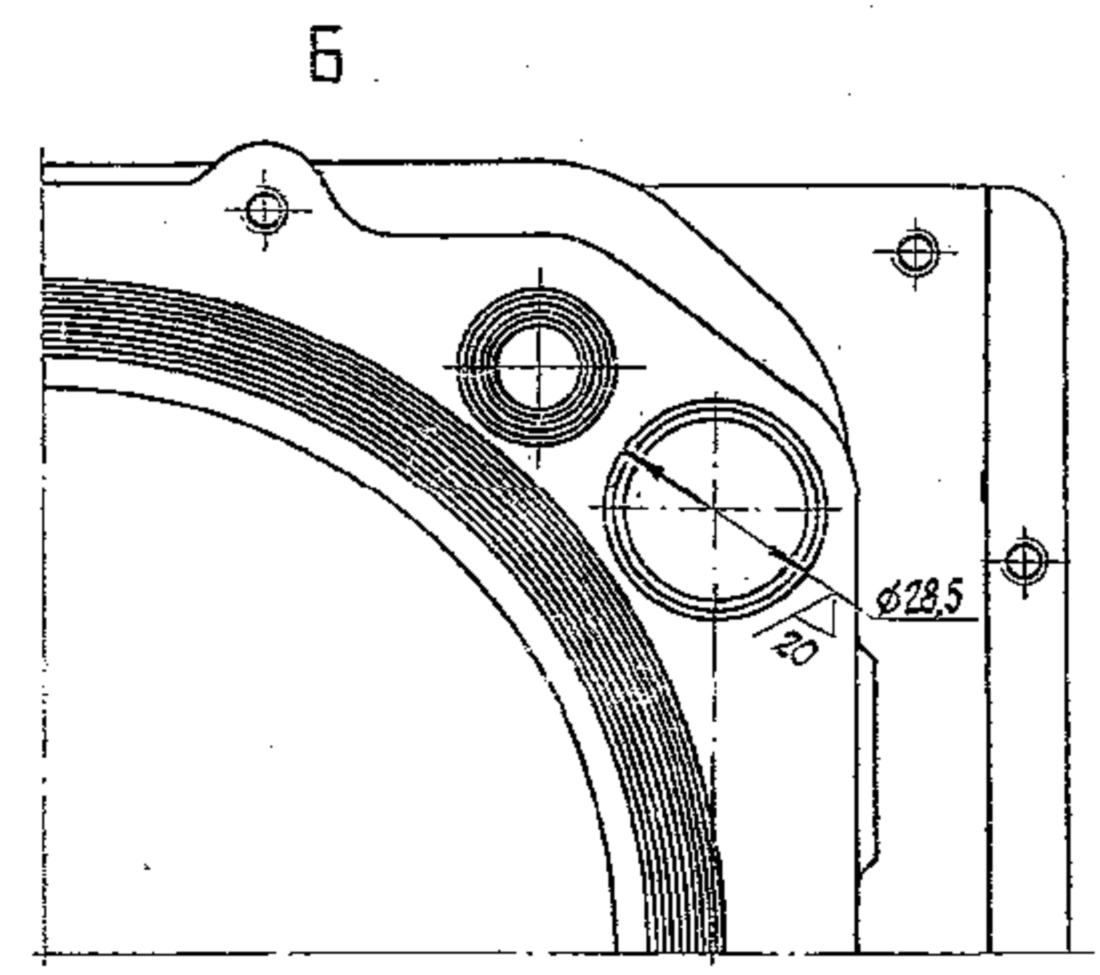
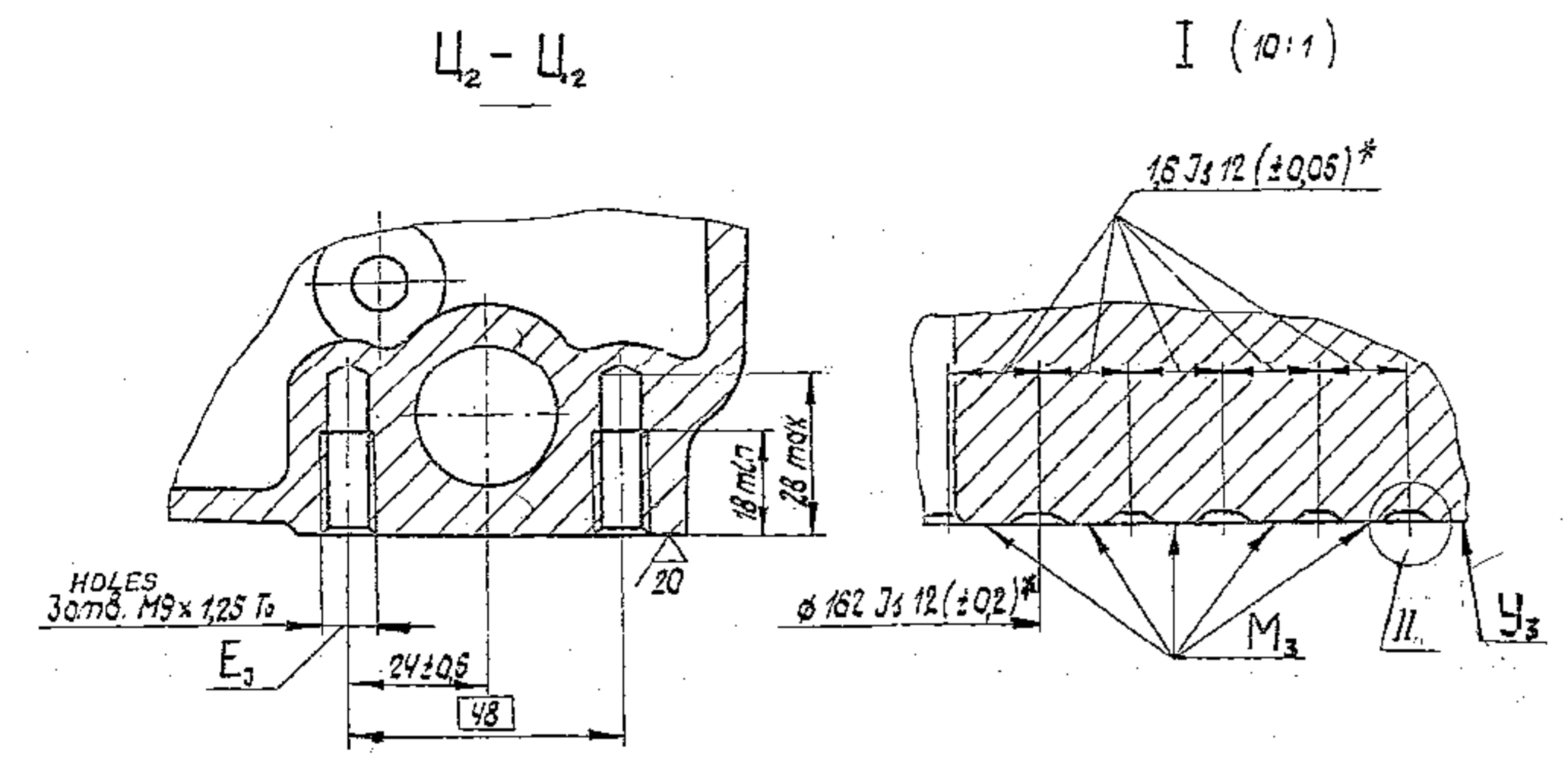
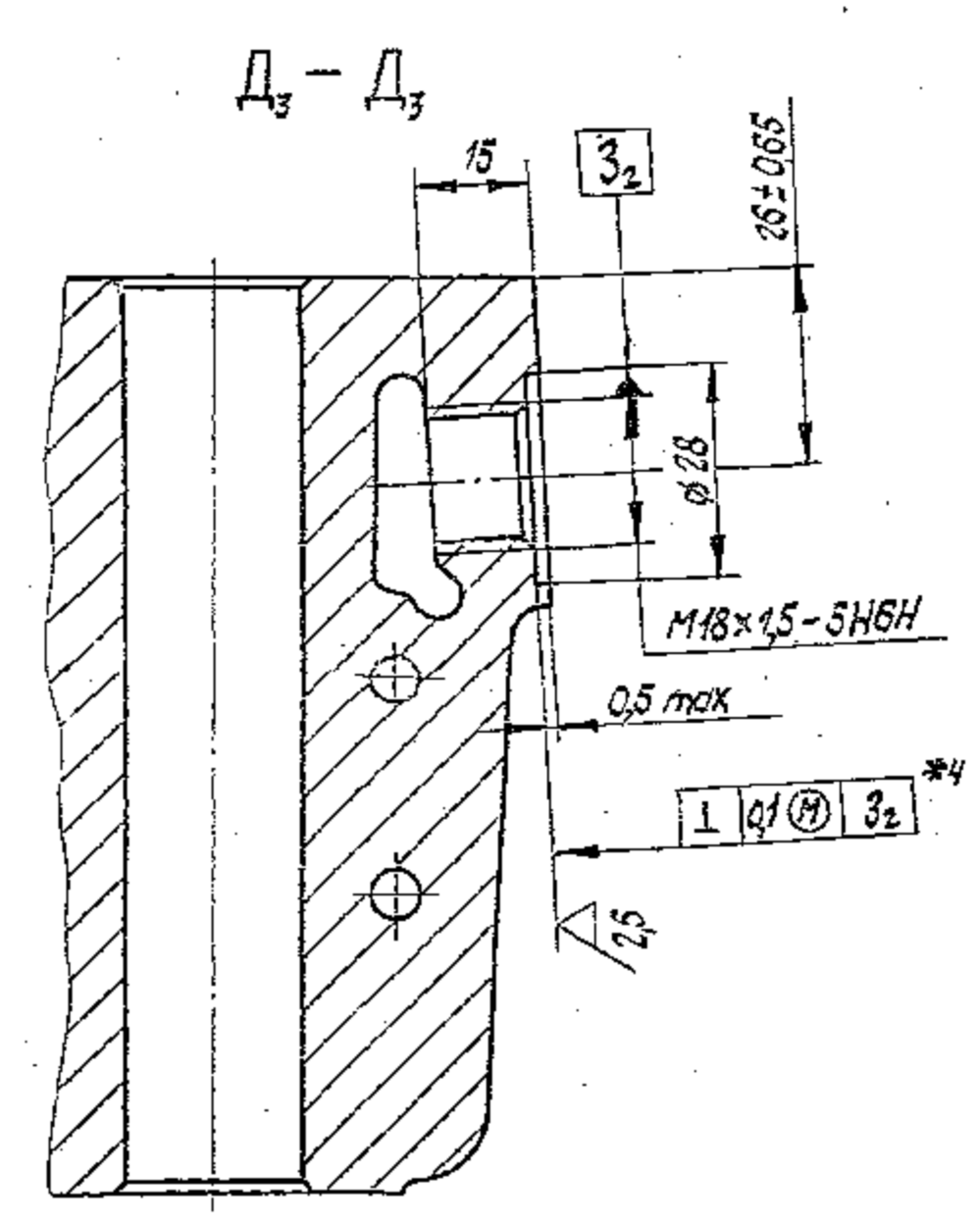
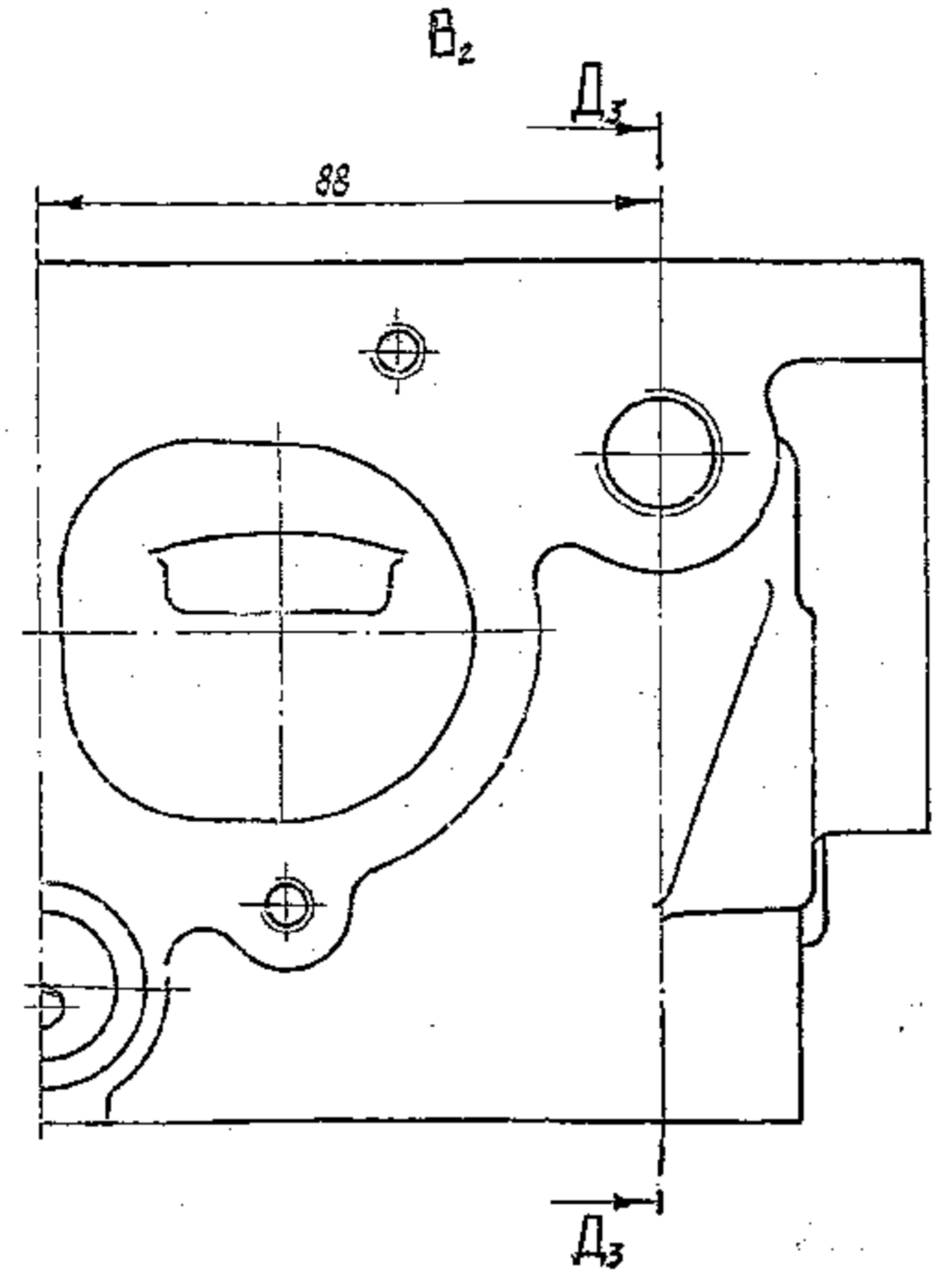
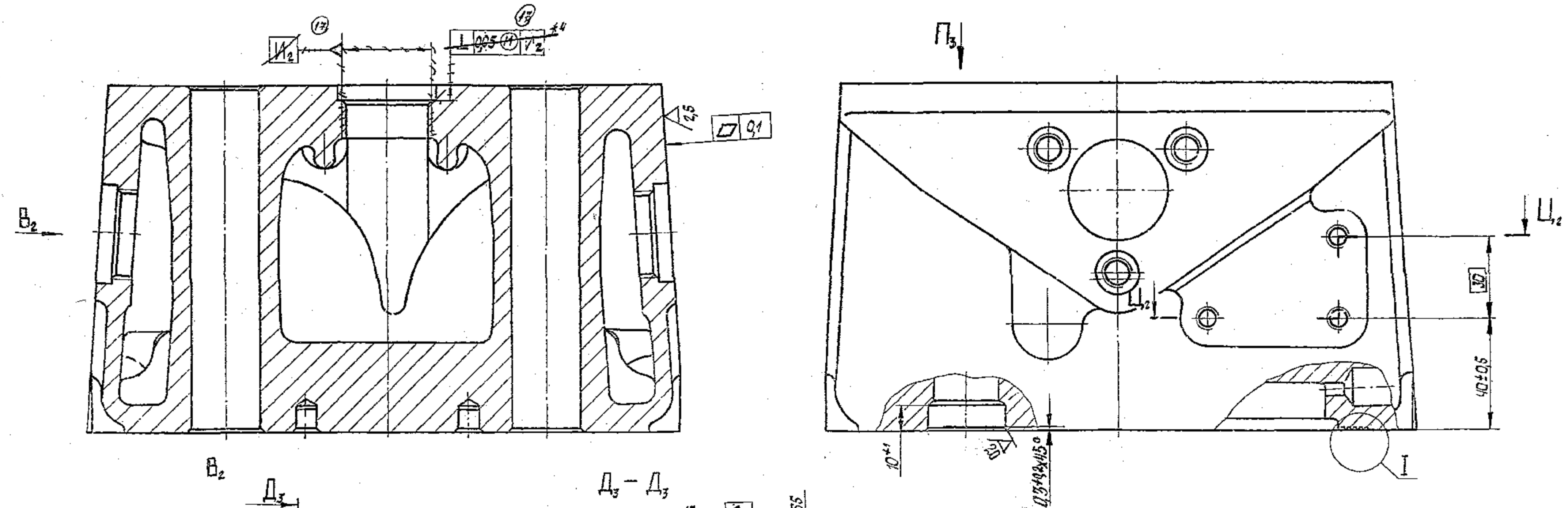

PILOT SAMPLE SHOULD BE APPROVED BY A I S P BEFORE BULK PRODUCTION.

EST. WT. (kg) TO BE STAMPED OR MARKED WHERE INDICATED THIS # (LETTERS)

ALL SHARP EDGES AND CORNERS TO BE REMOVED UNLESS OTHERWISE STATED MACHINED CORNERS TO HAVE R OUTSIDE R INSIDE EQUIVALENT CHAMFERS ARE PERMISSIBLE.

DRN	CHP	APFD	DATE	SCALE	DIMENSIONS	TOLERANCE	ALL TREADS	MATERIAL	USED ON
			16-05-2012	1:1	mm	UNLESS OTHERWISE STATED IS: 2102-69	TO CONFORM TO		CB.306-01-20
								CONTROLLERATE OF QUALITY ASSURANCE (HEAVY VEHICLES) AVADI	
								TITLE	
								R.H CYLINDER HEAD	
								D S CAT NUMBER	DRAWING NUMBER
									306-16-19
ISSUE	DATE	NATURE OF AMENDMENTS							

DRG. INDIANISED BASED ON RUSSIAN ORIGINAL ISSUE - 17 AND DRG REPLACES ISSUE A VIDE 18th TRIG POINT No. 2

一、

二、

三、

四、

五、

六、

七、

八、

九、

十、

十一、



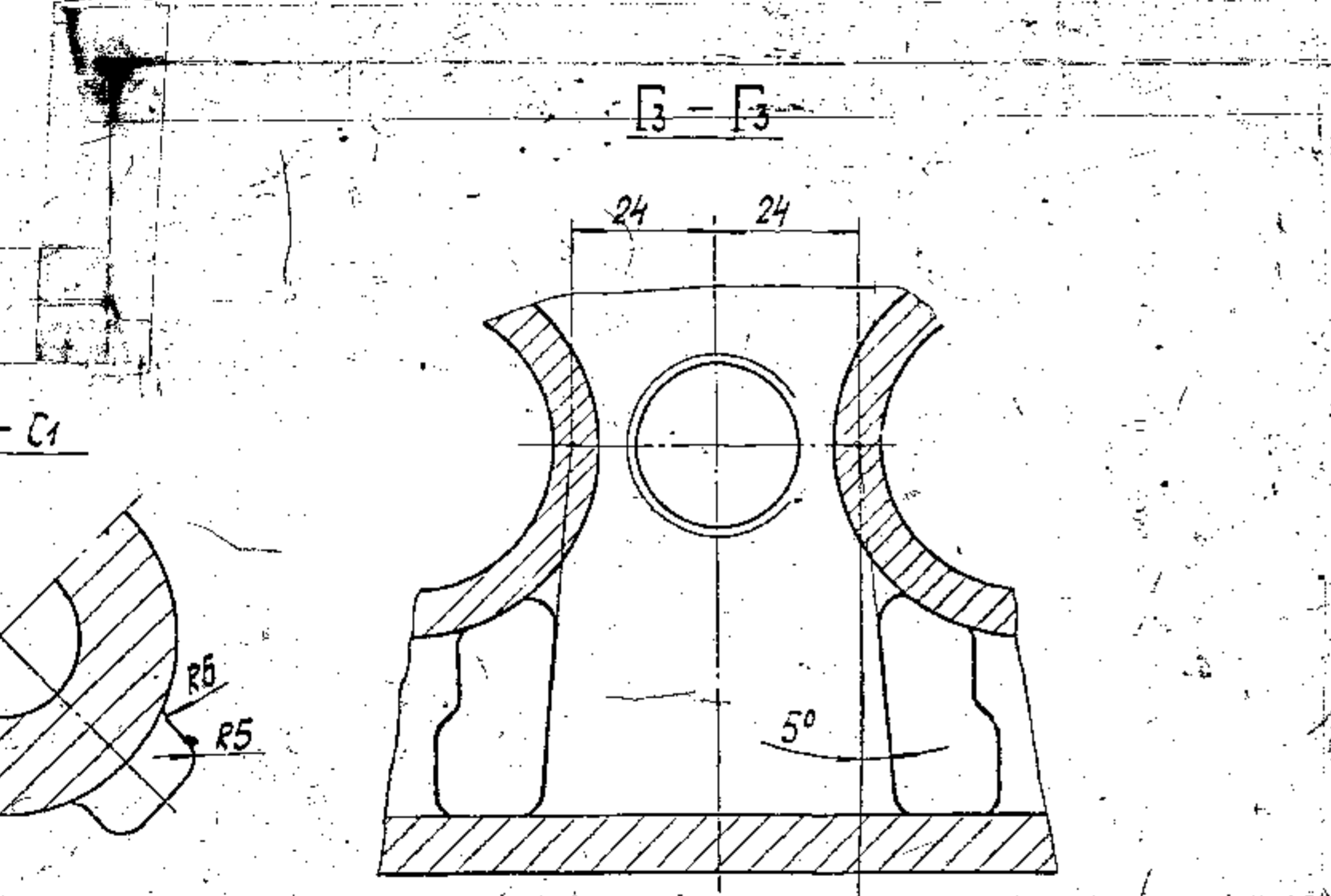
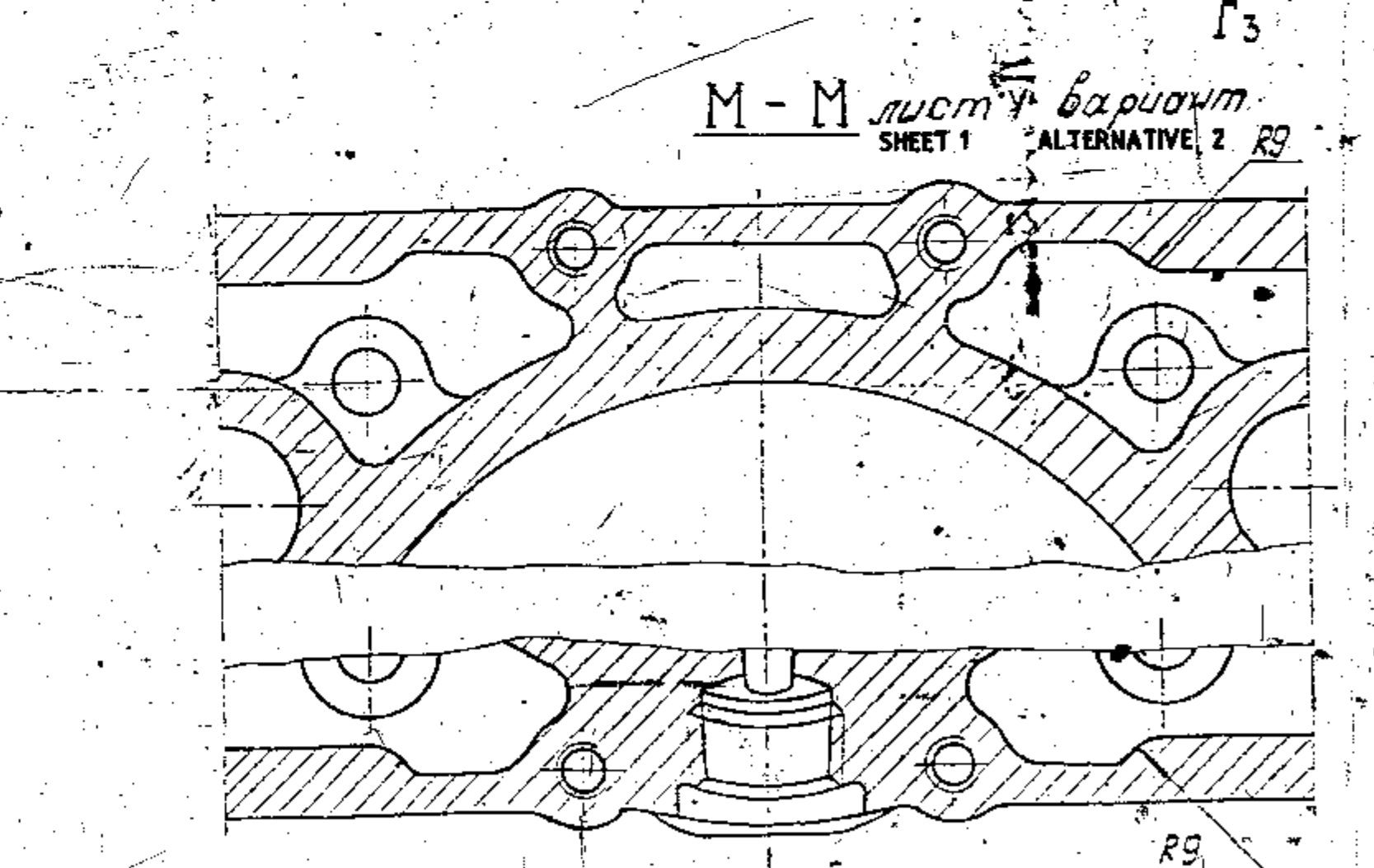
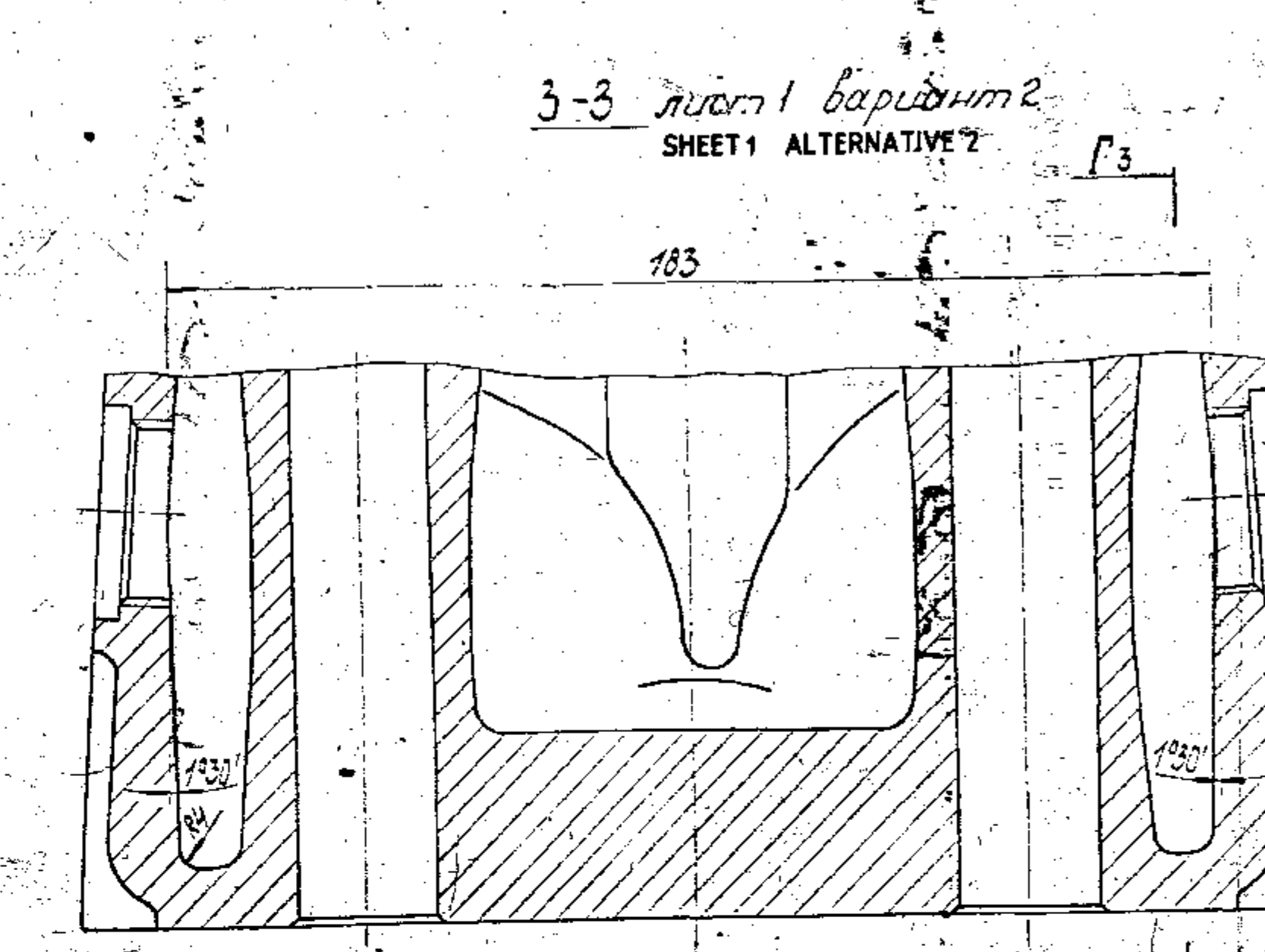
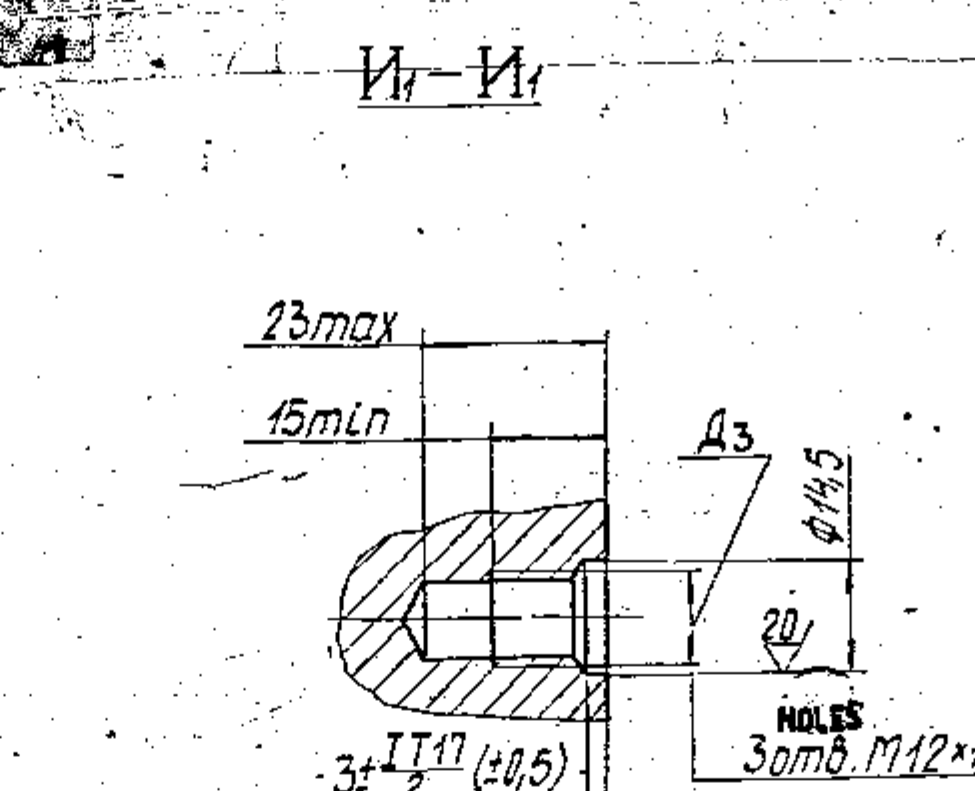
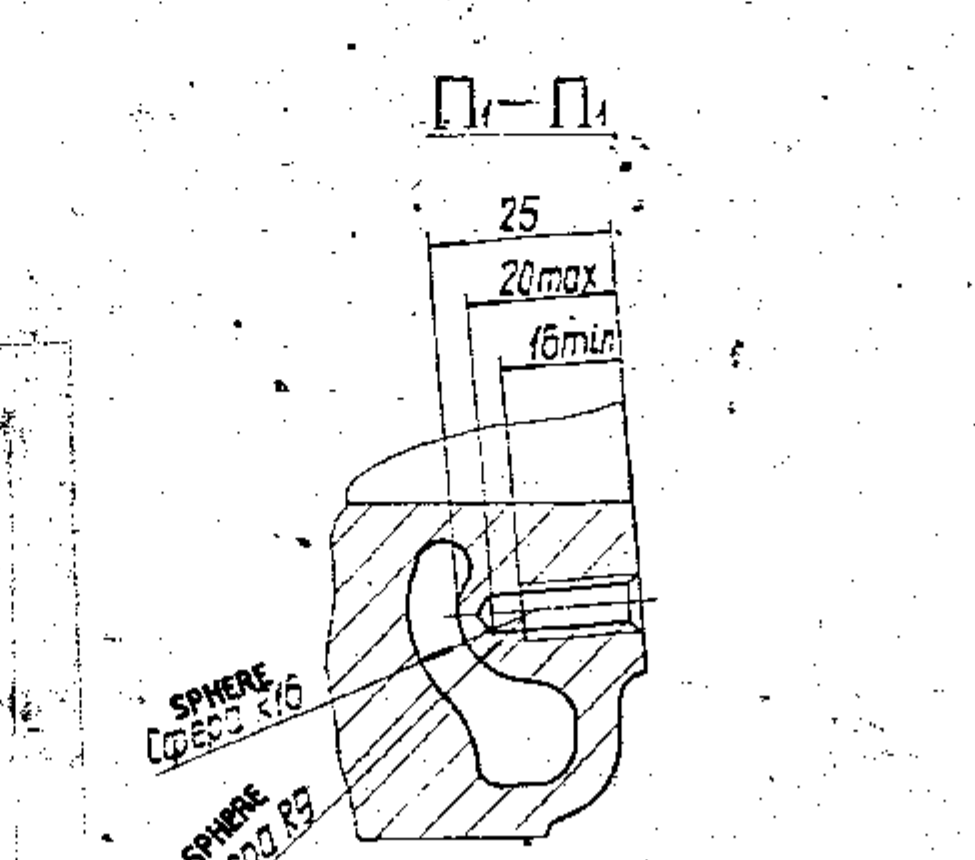
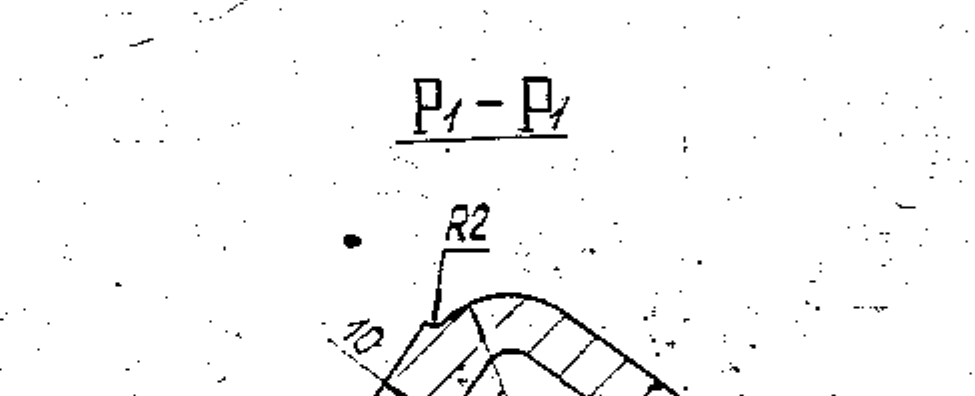
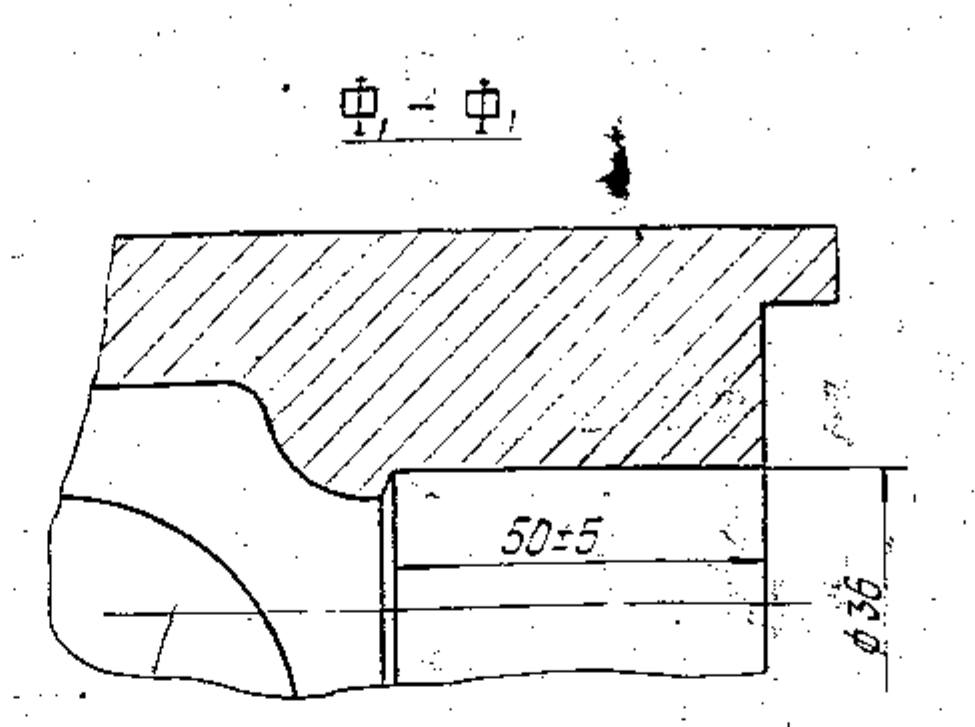
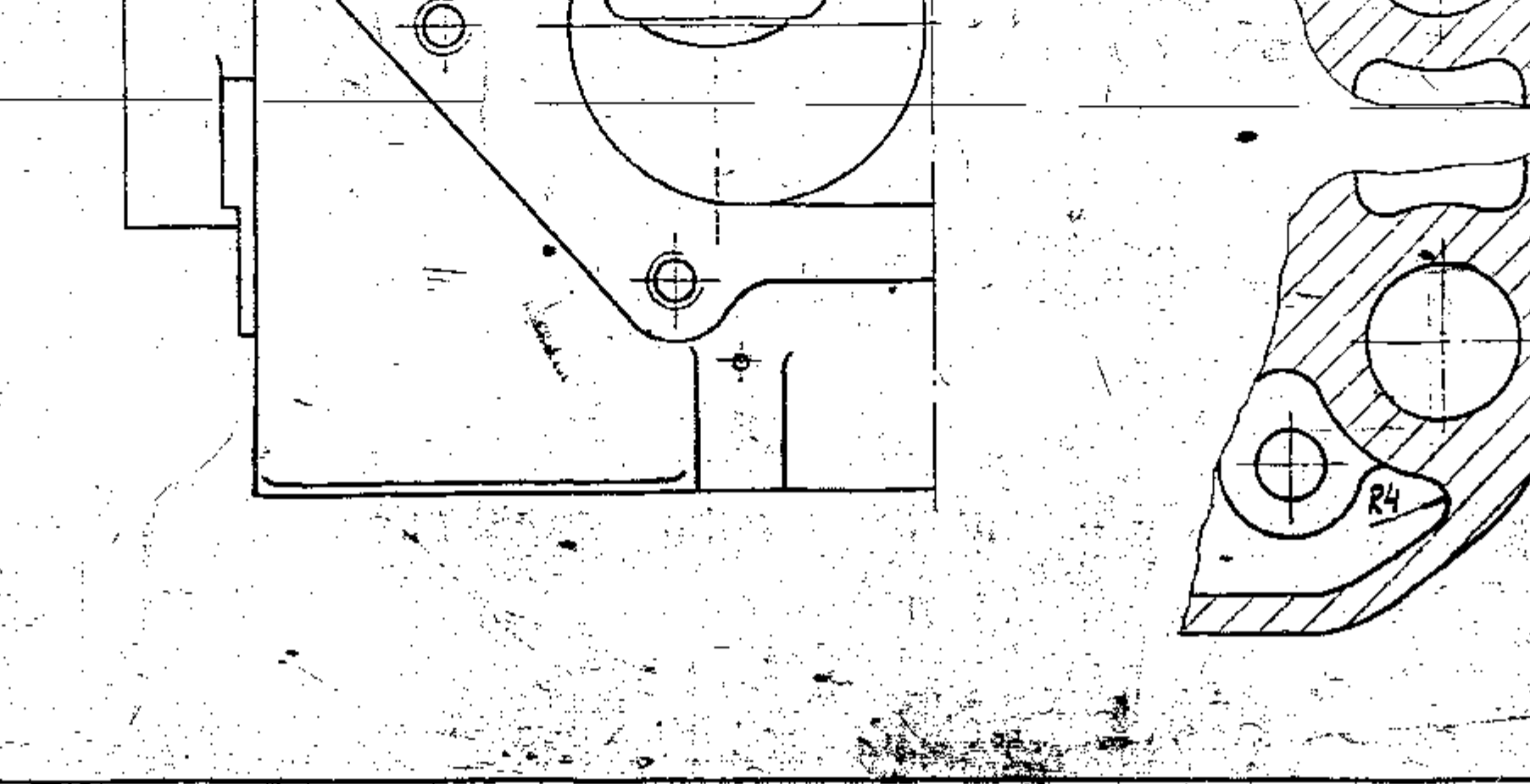
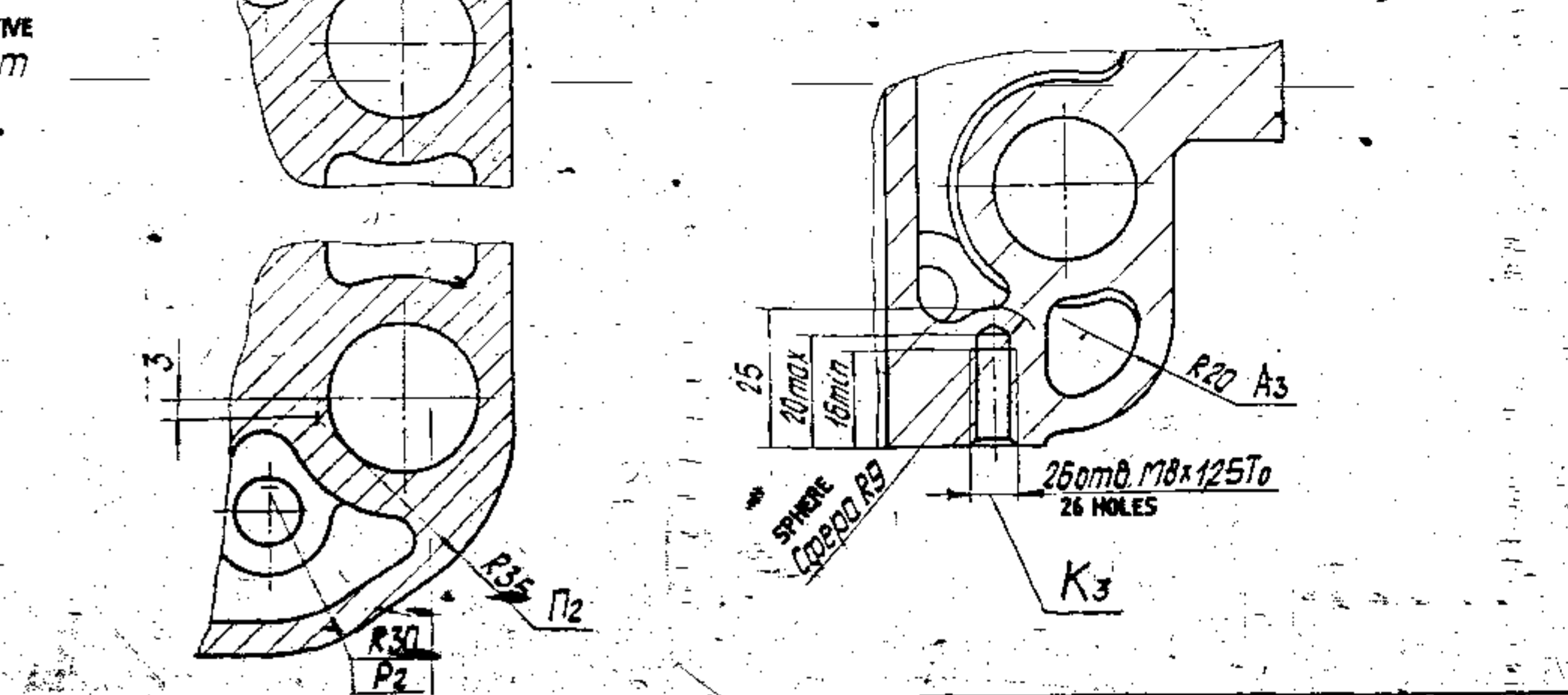
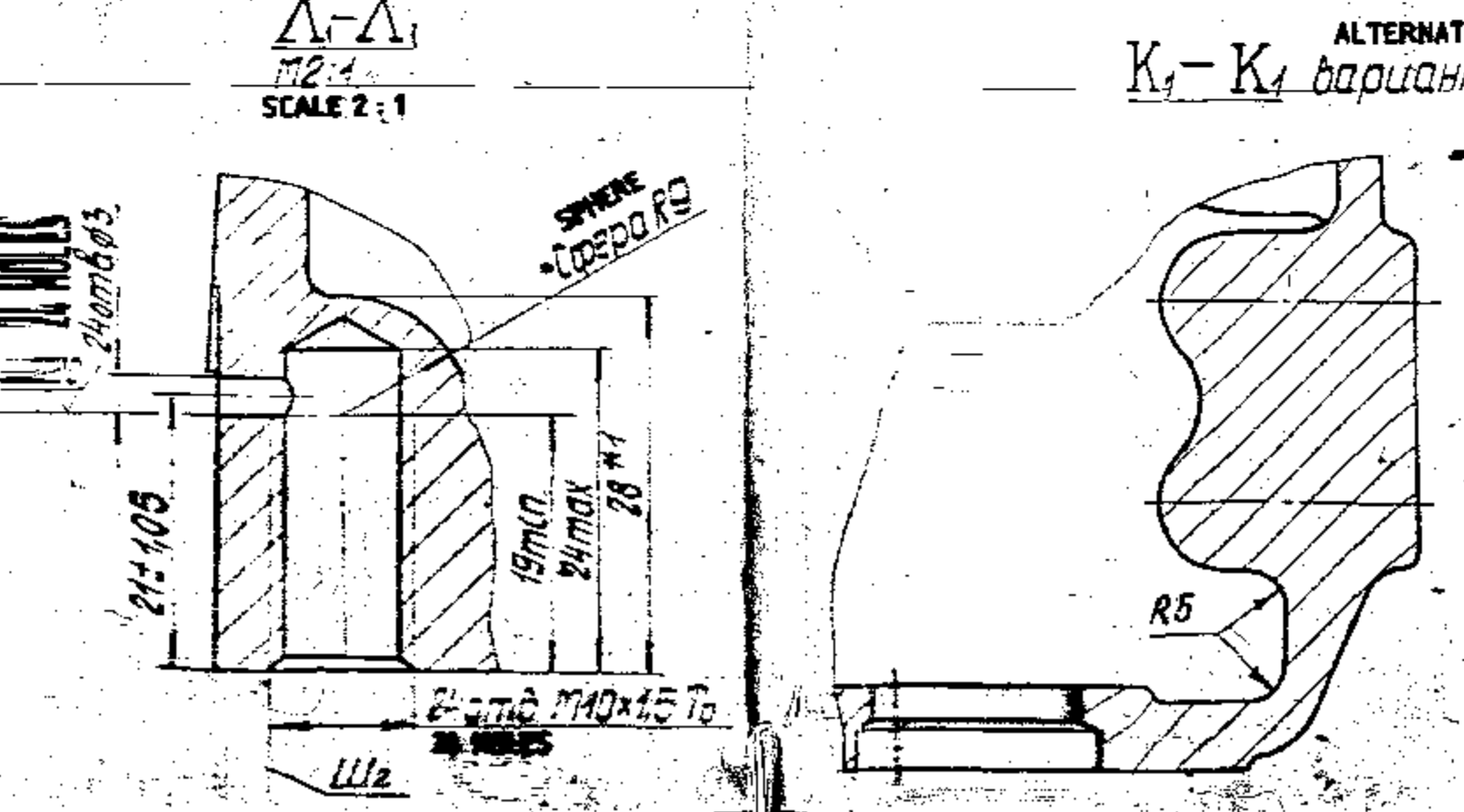
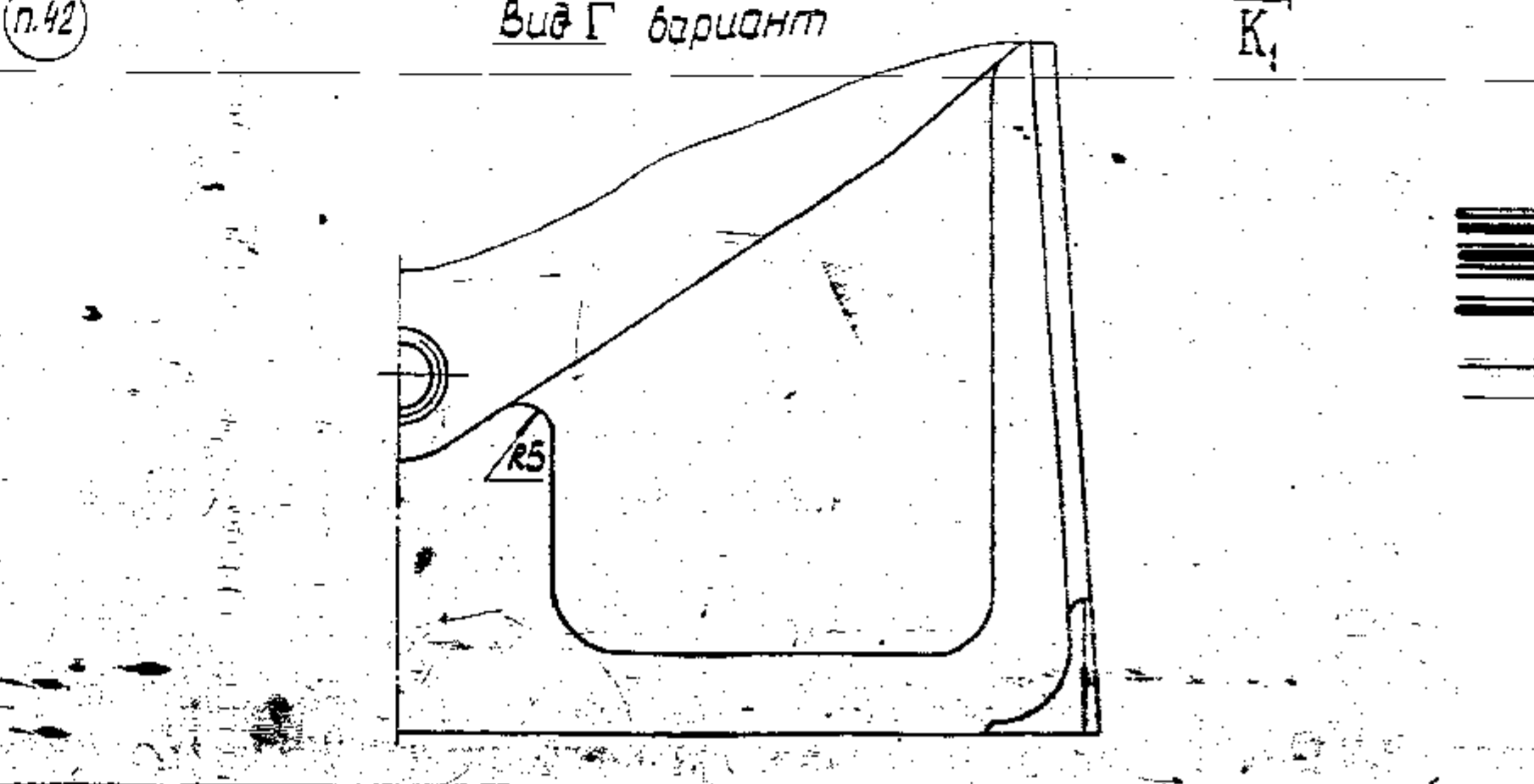
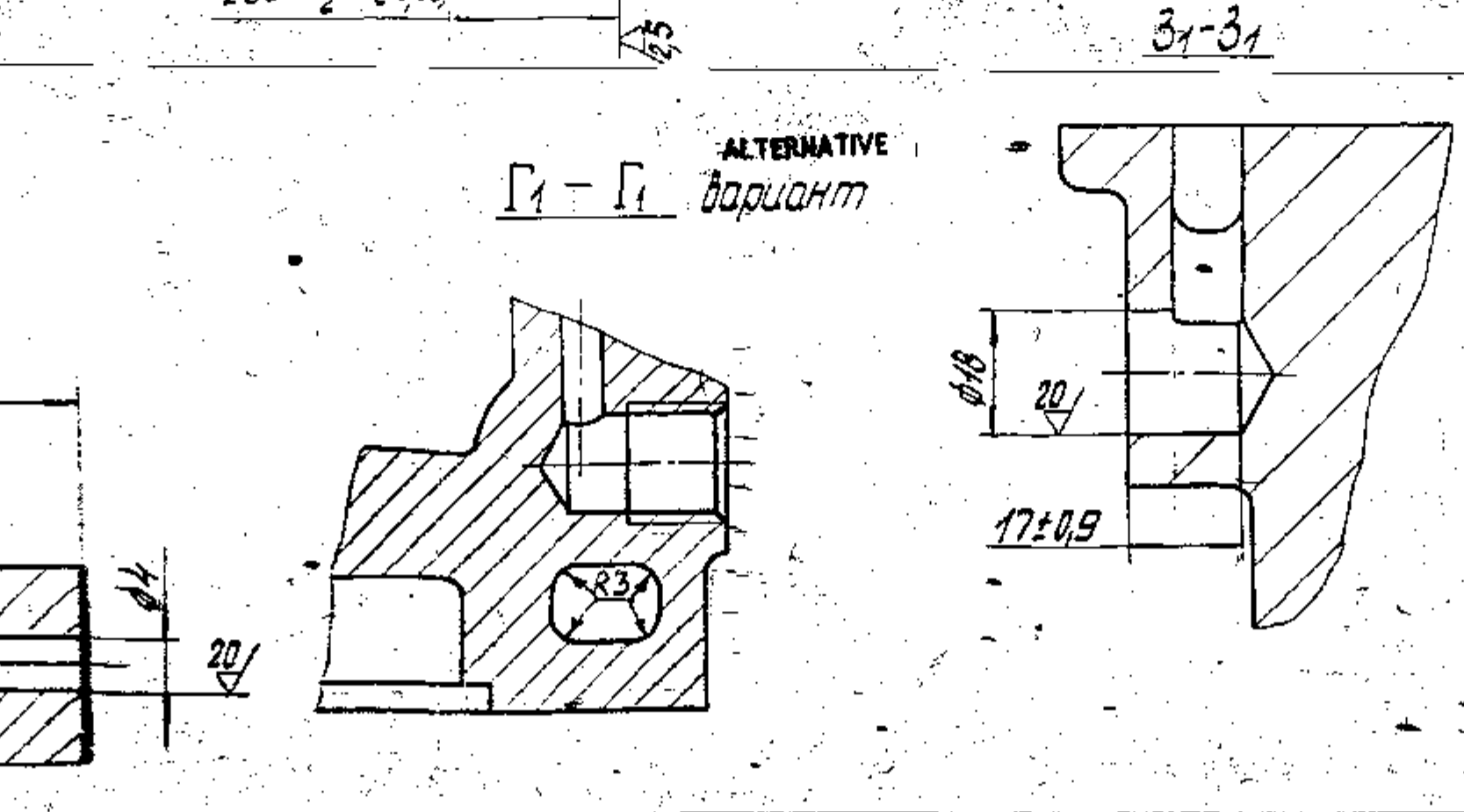
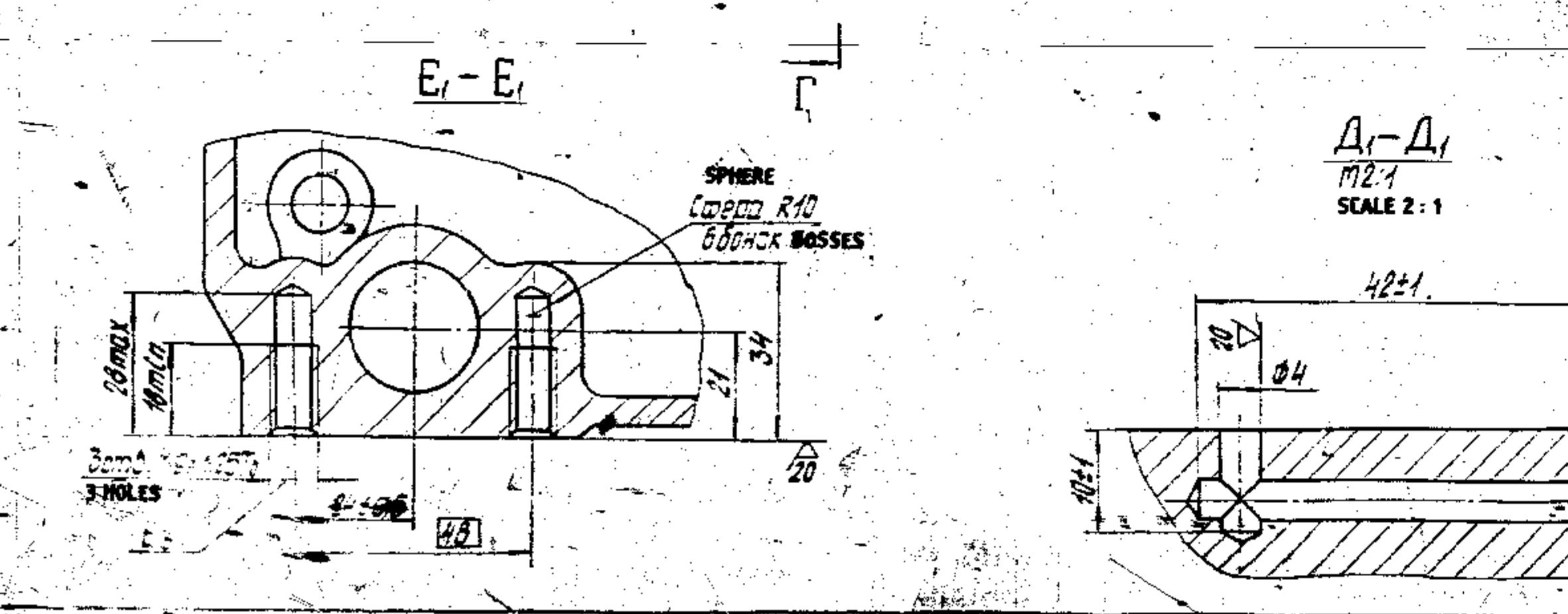
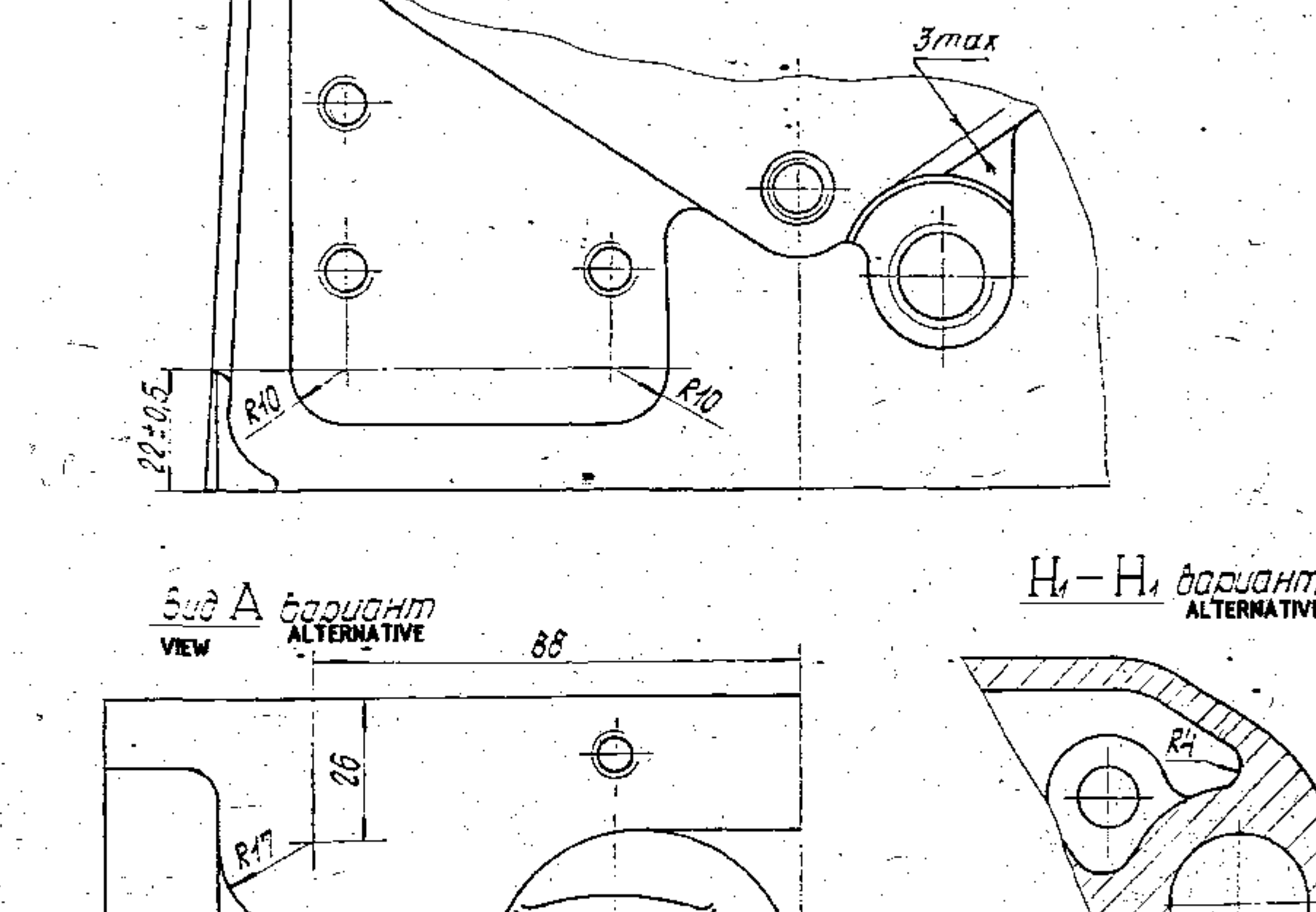
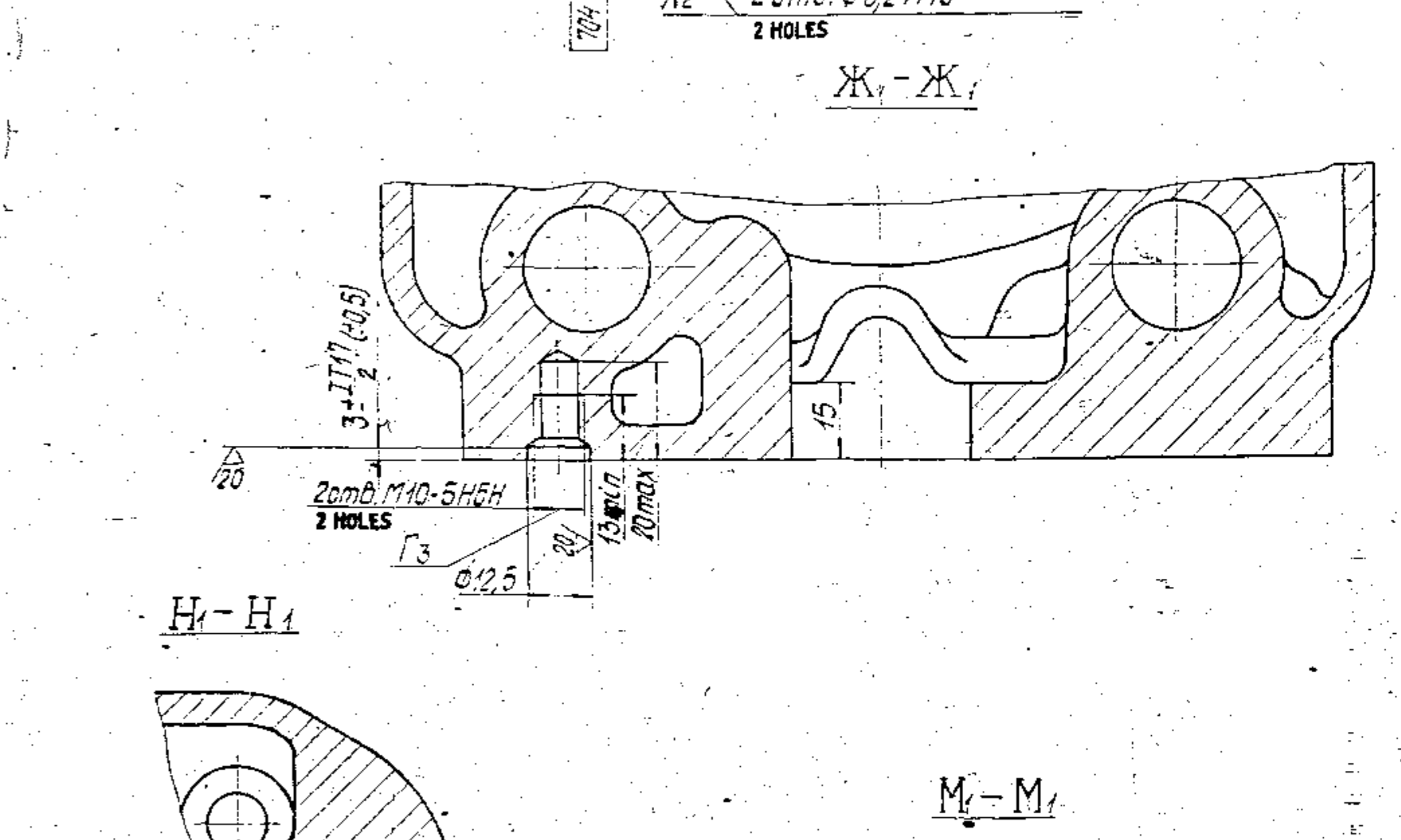
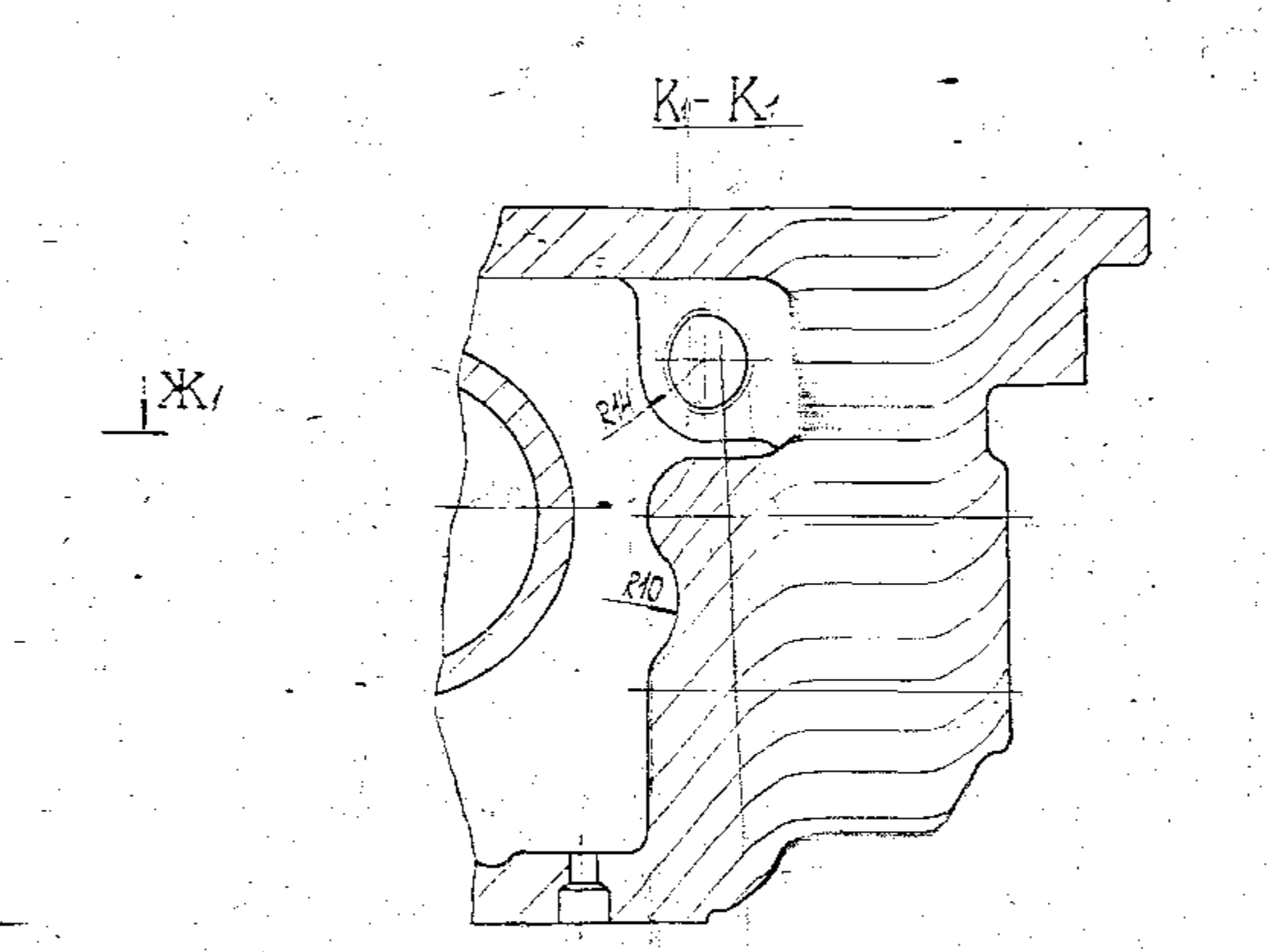
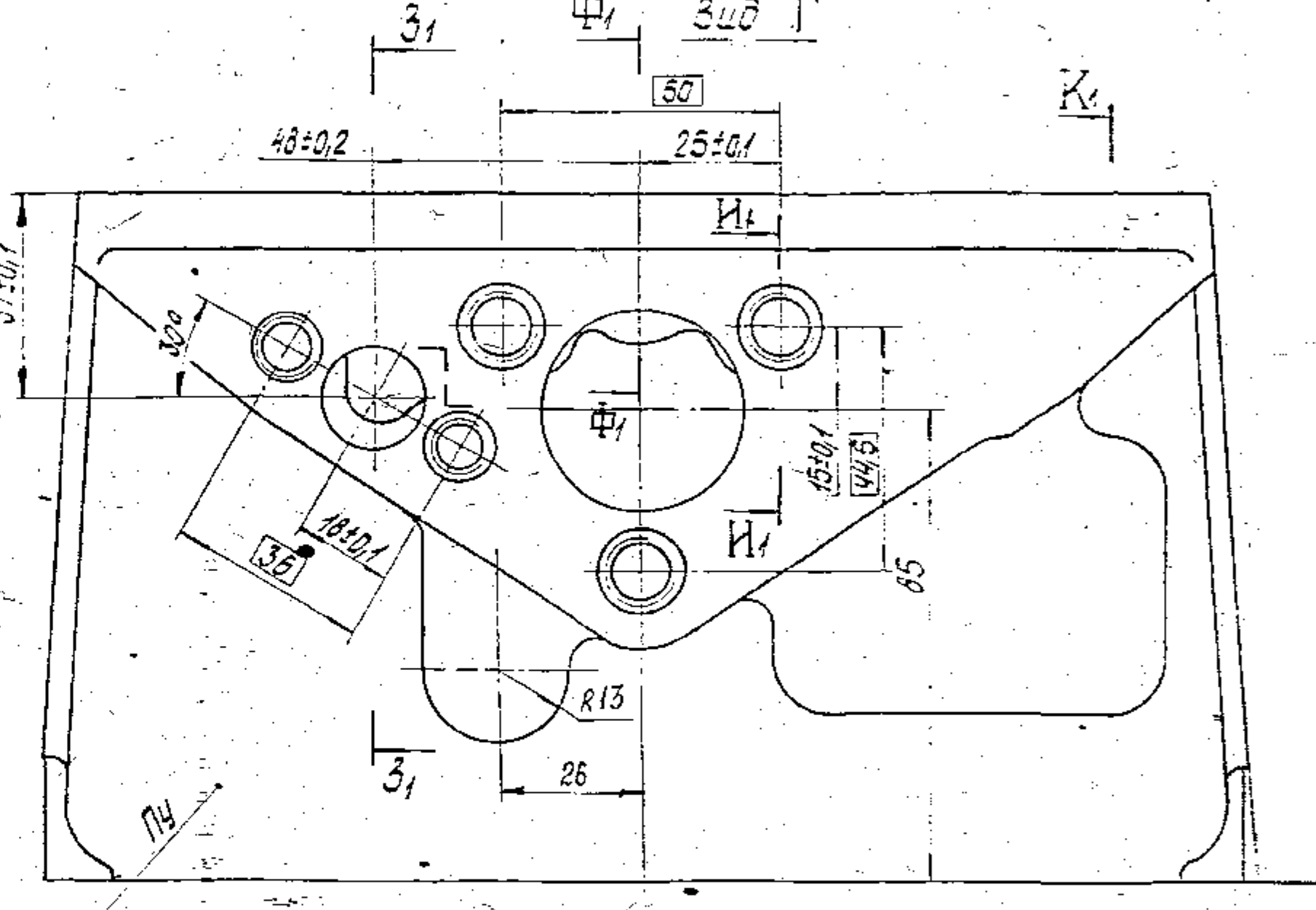
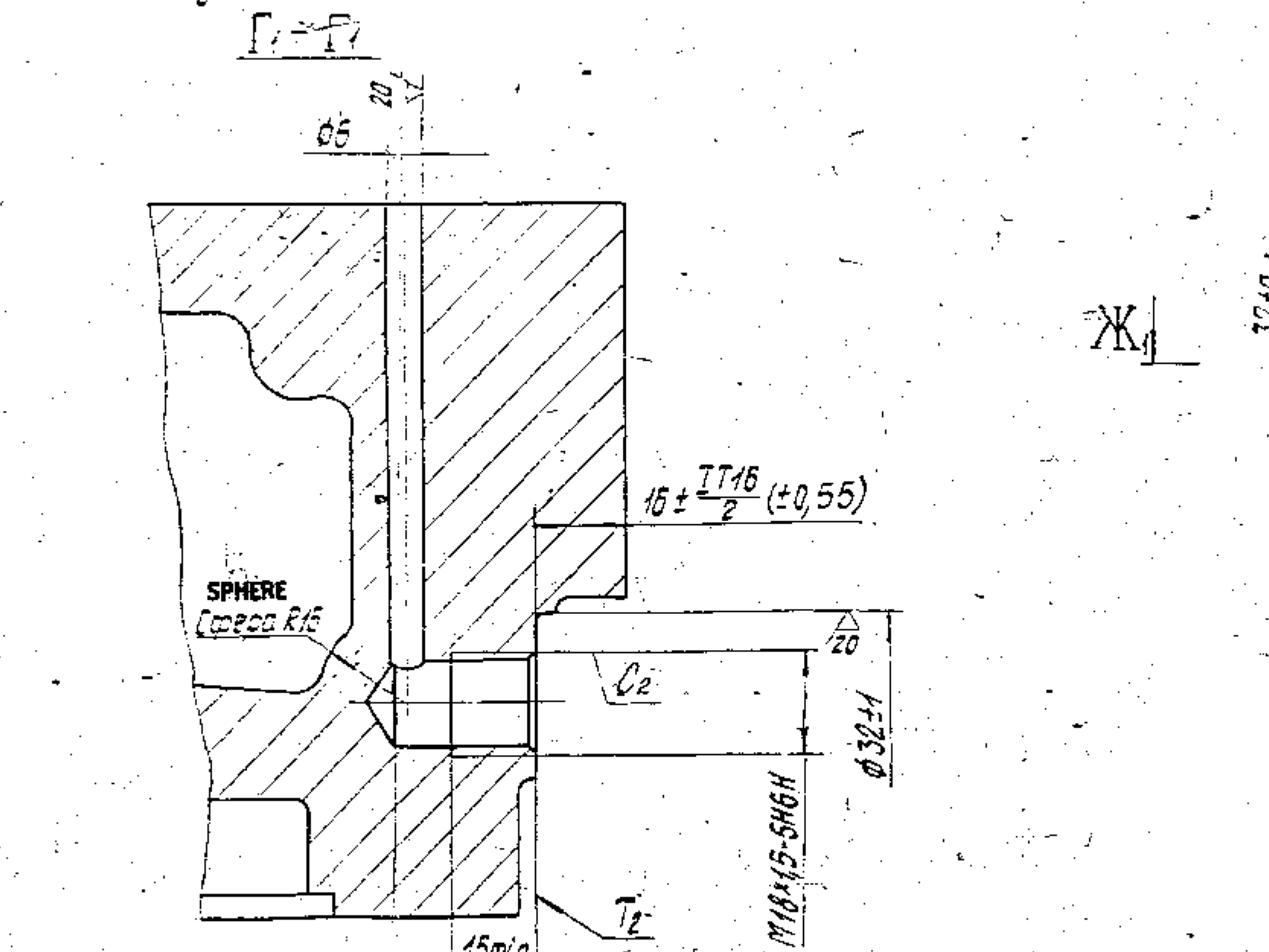
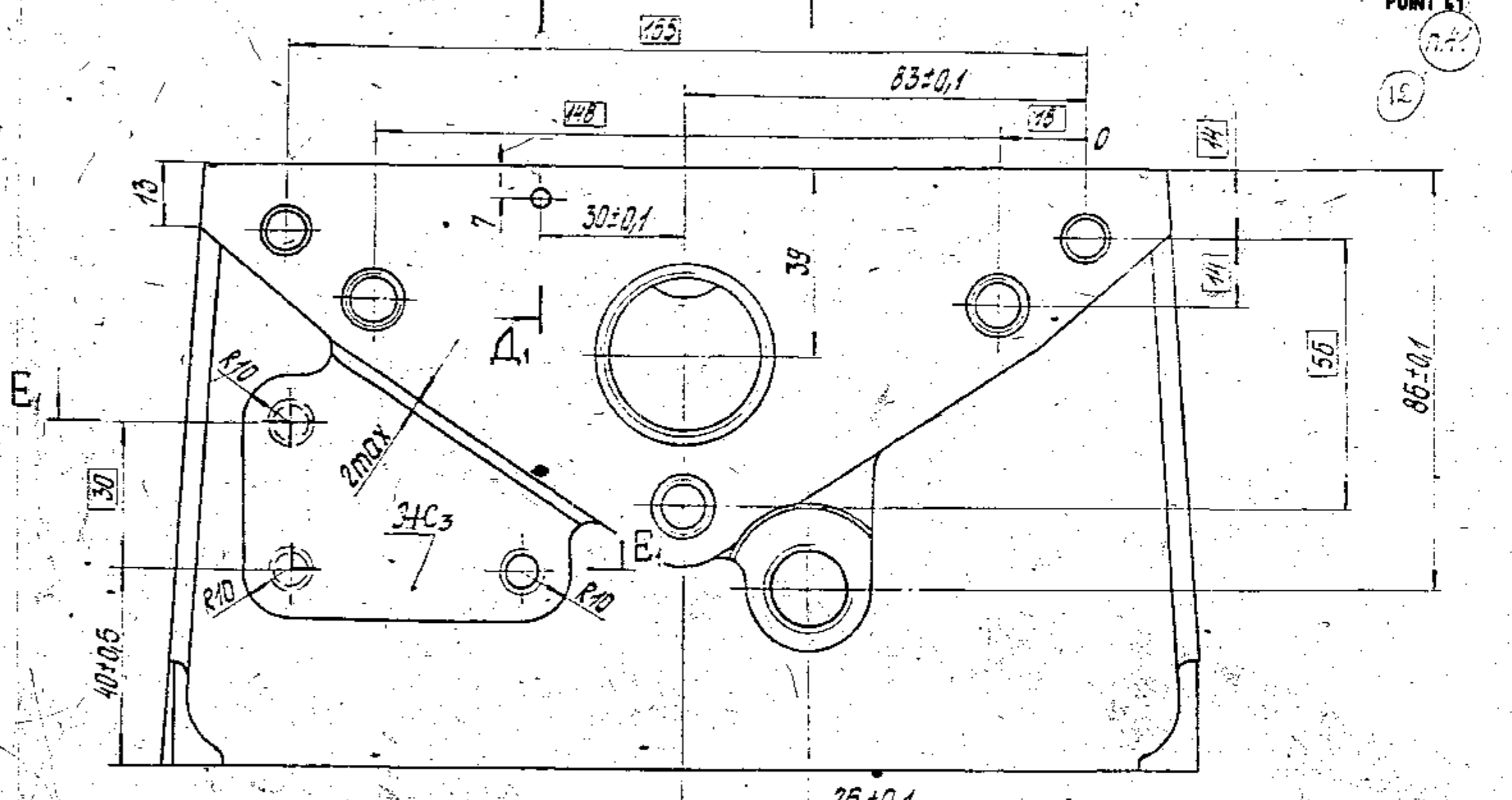



PLET SAMPLE SHOULD BE APPROVED BY A N S F BEFORE BULK PRODUCTION TO BE STAMPED BY FORKED LETTERS	
NET. MASS 36.61 KG	INDICATED THIS 0
ALL SHARP EDGES AND CORNERS TO BE REMOVED UNLESS OTHERWISE STATED HALLOWED CORNERS TO REMAIN IF APPROPRIATE IN CASE DIMENSIONAL CHANGES ARE PERMISSIBLE	MATERIAL: A 9 BUST 2485 - 75
SCALE: 1:1	MADE IN: AYAZ
CONTROLLER OF QUALITY ASSURANCE HEAVY VEHICLES TITLE: BLOCK HEAD R M	DATE: 25-10-75 D S CAT NUMBER: 306-16-23 Str. 2



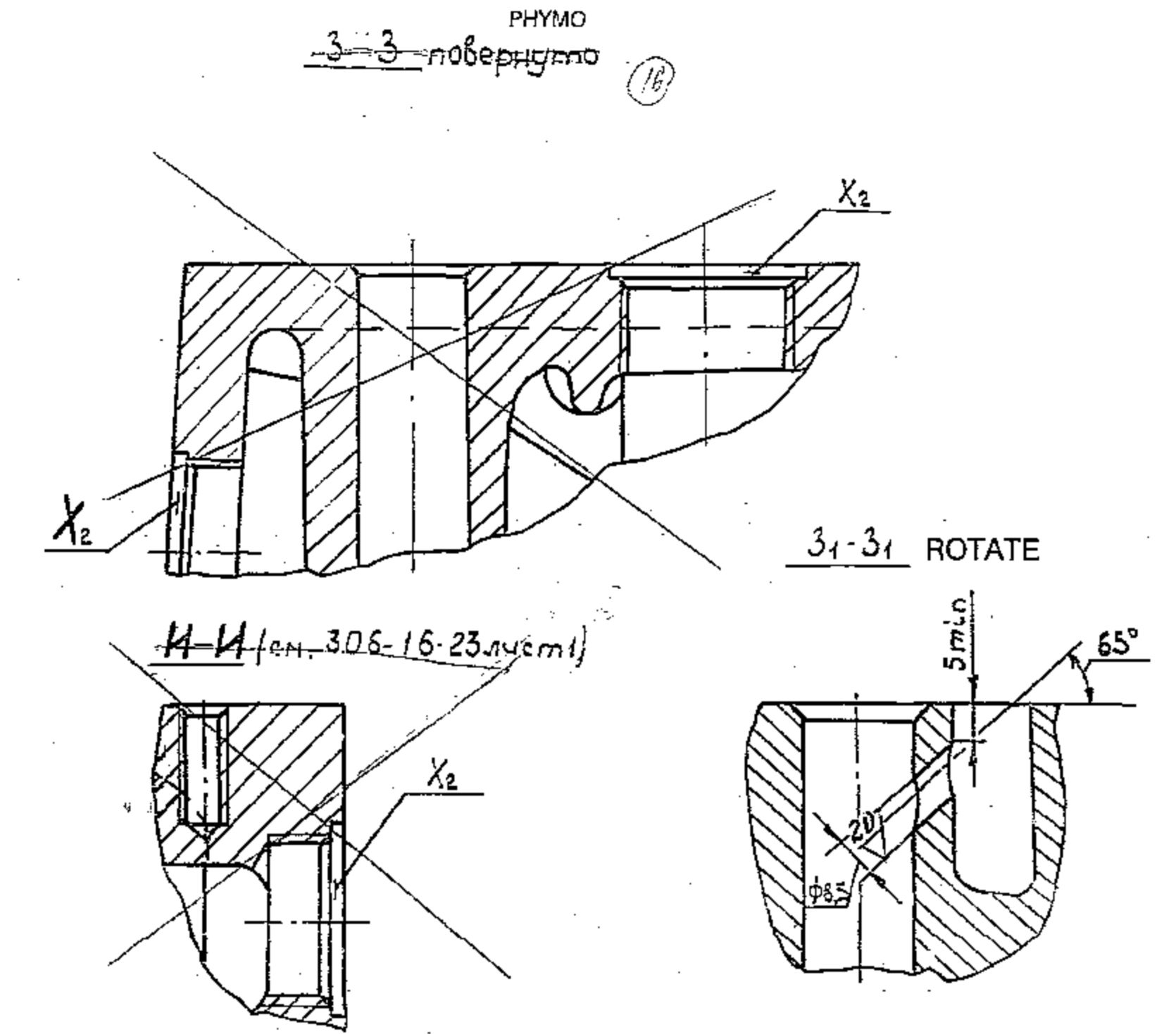
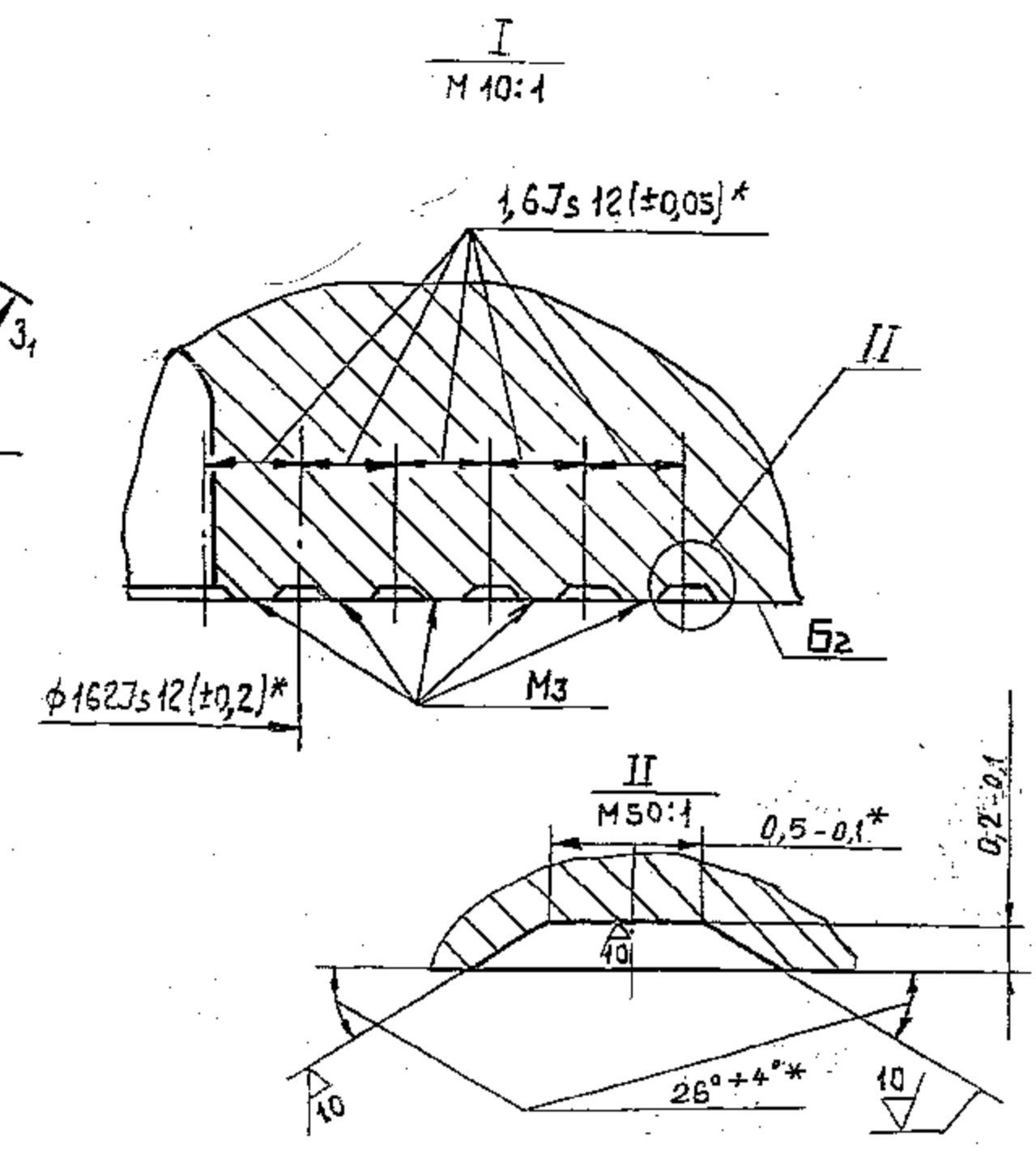
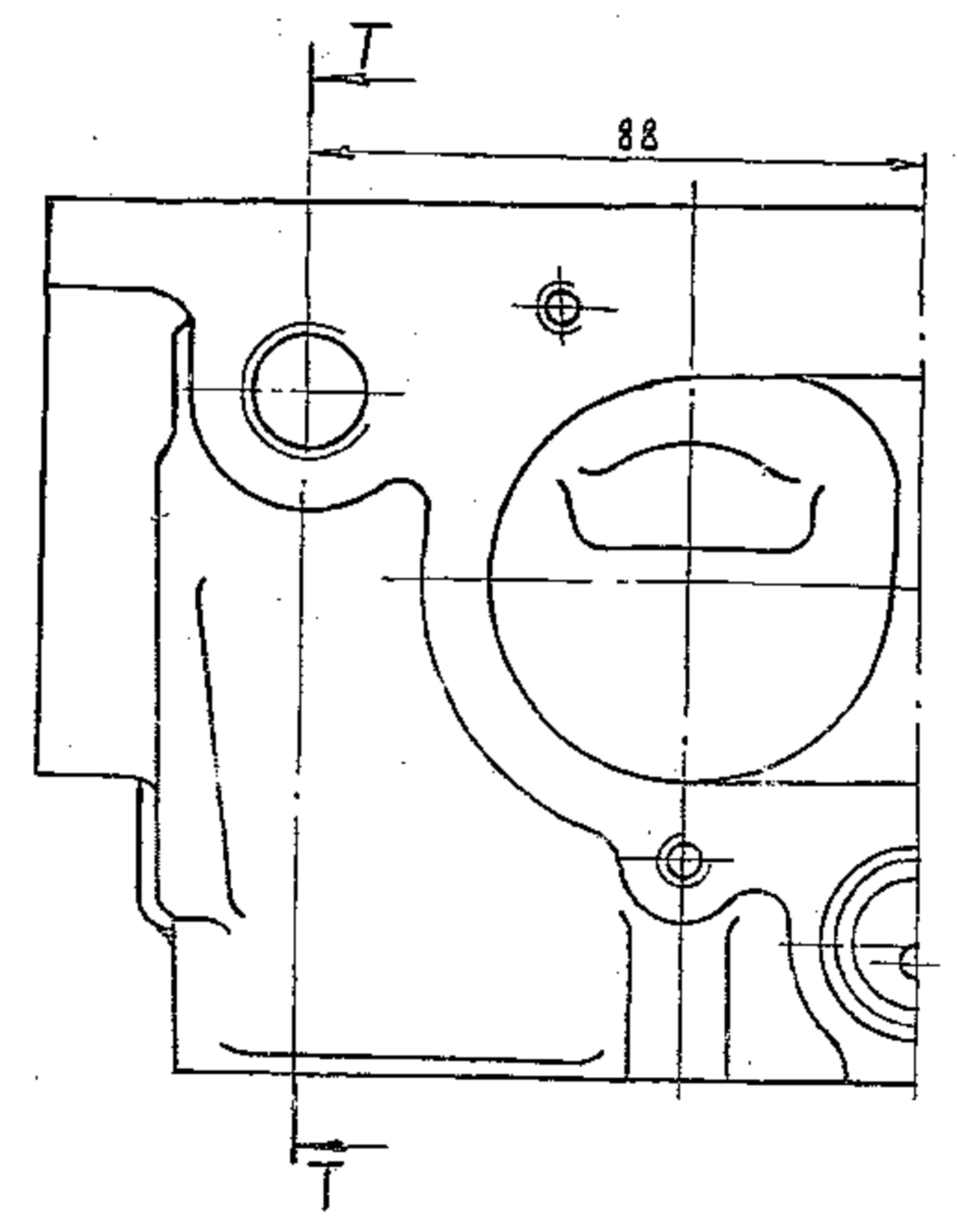
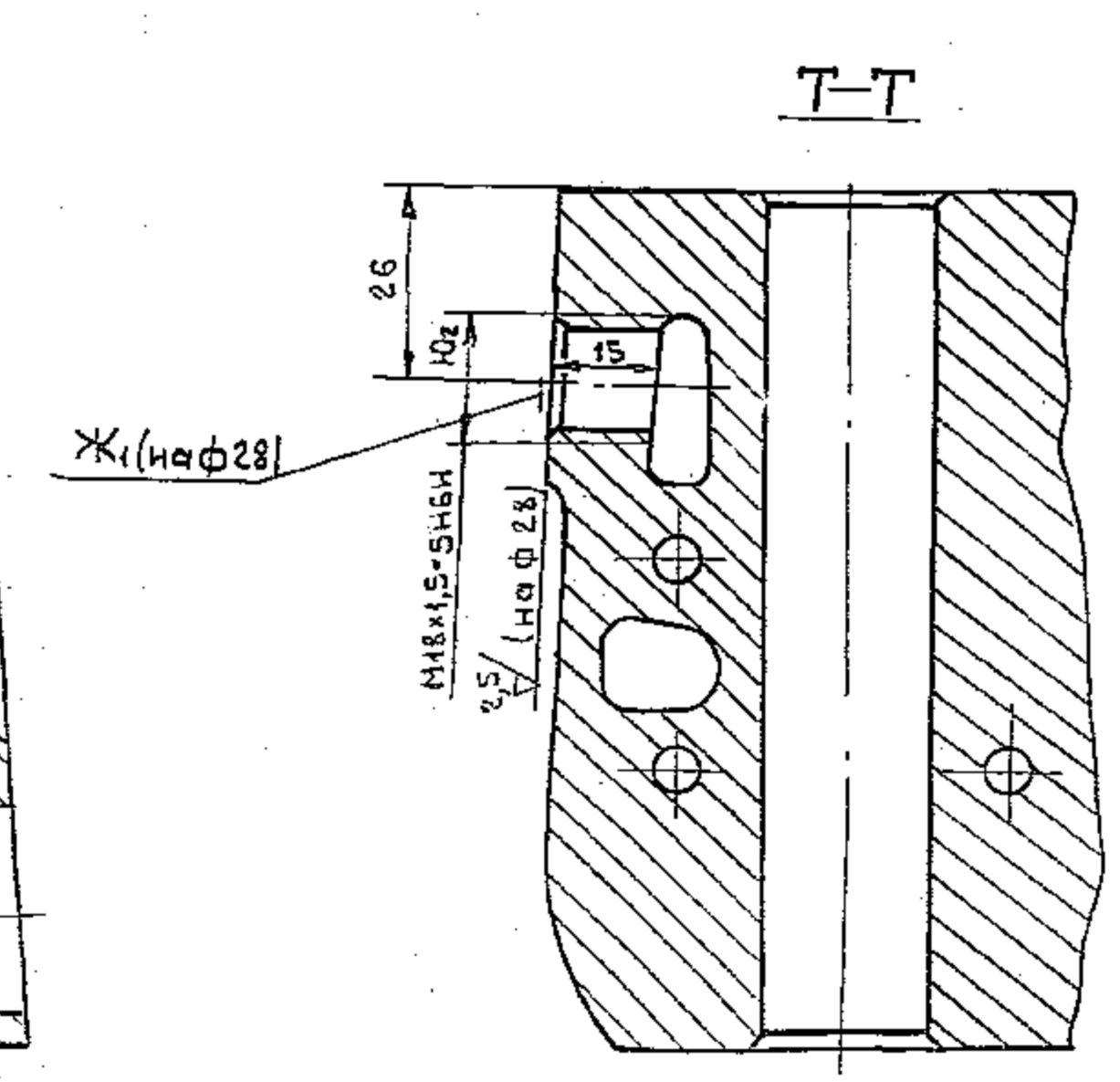
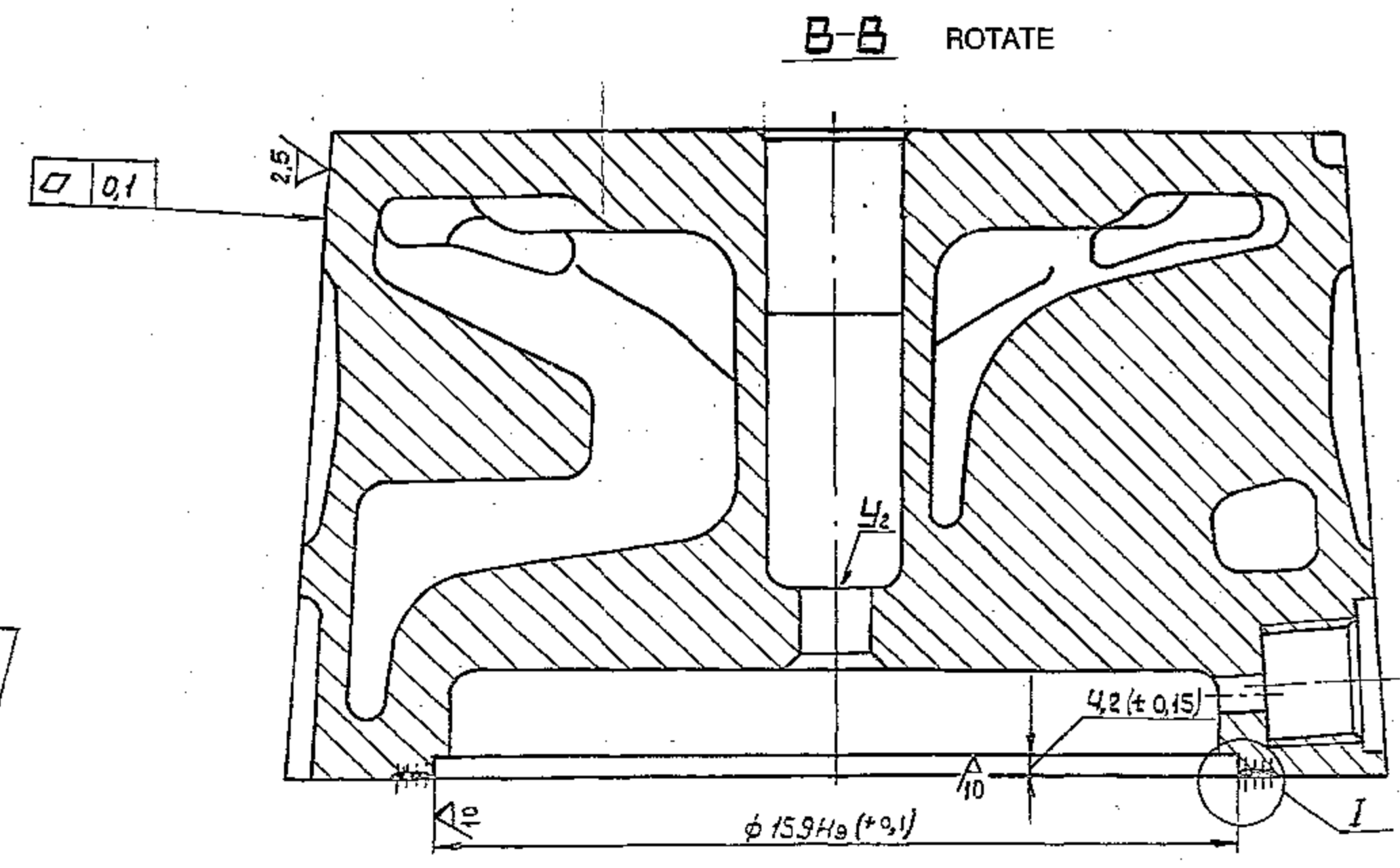
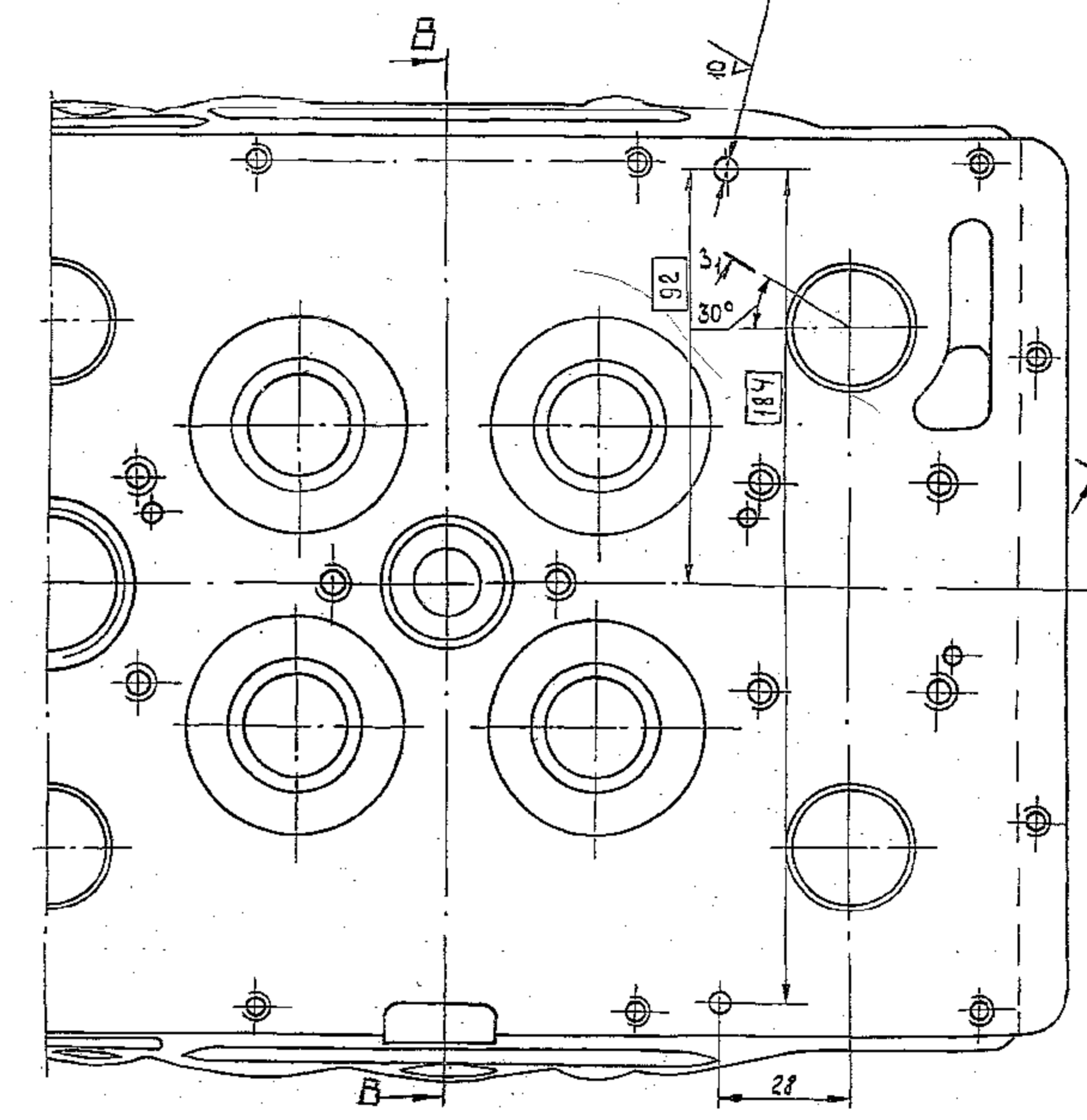
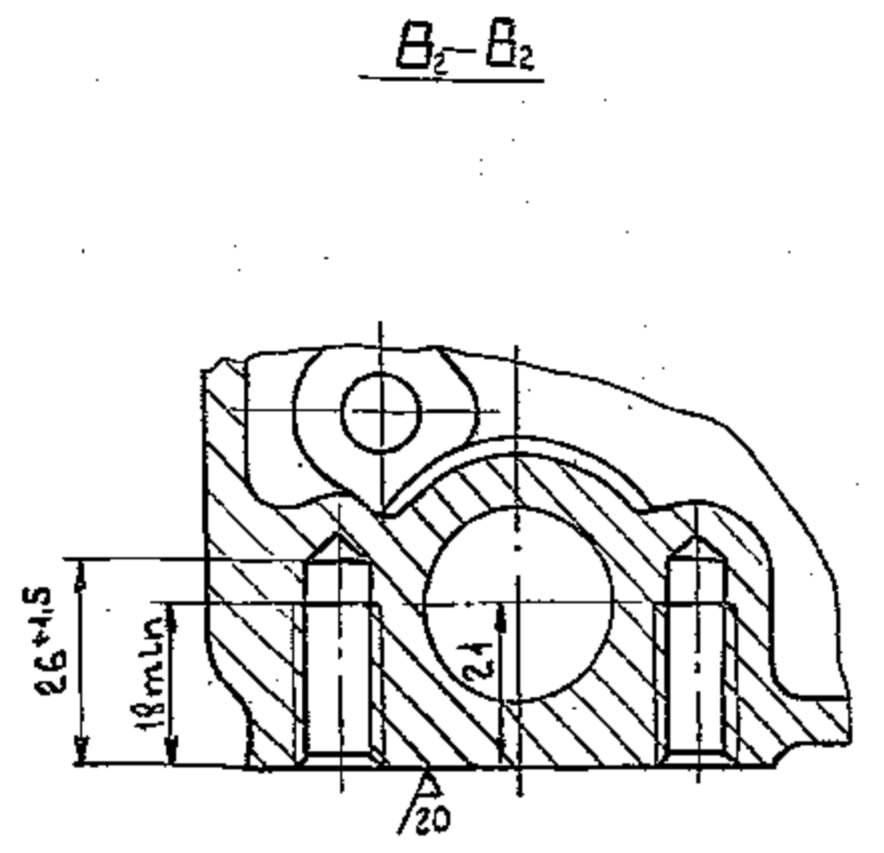
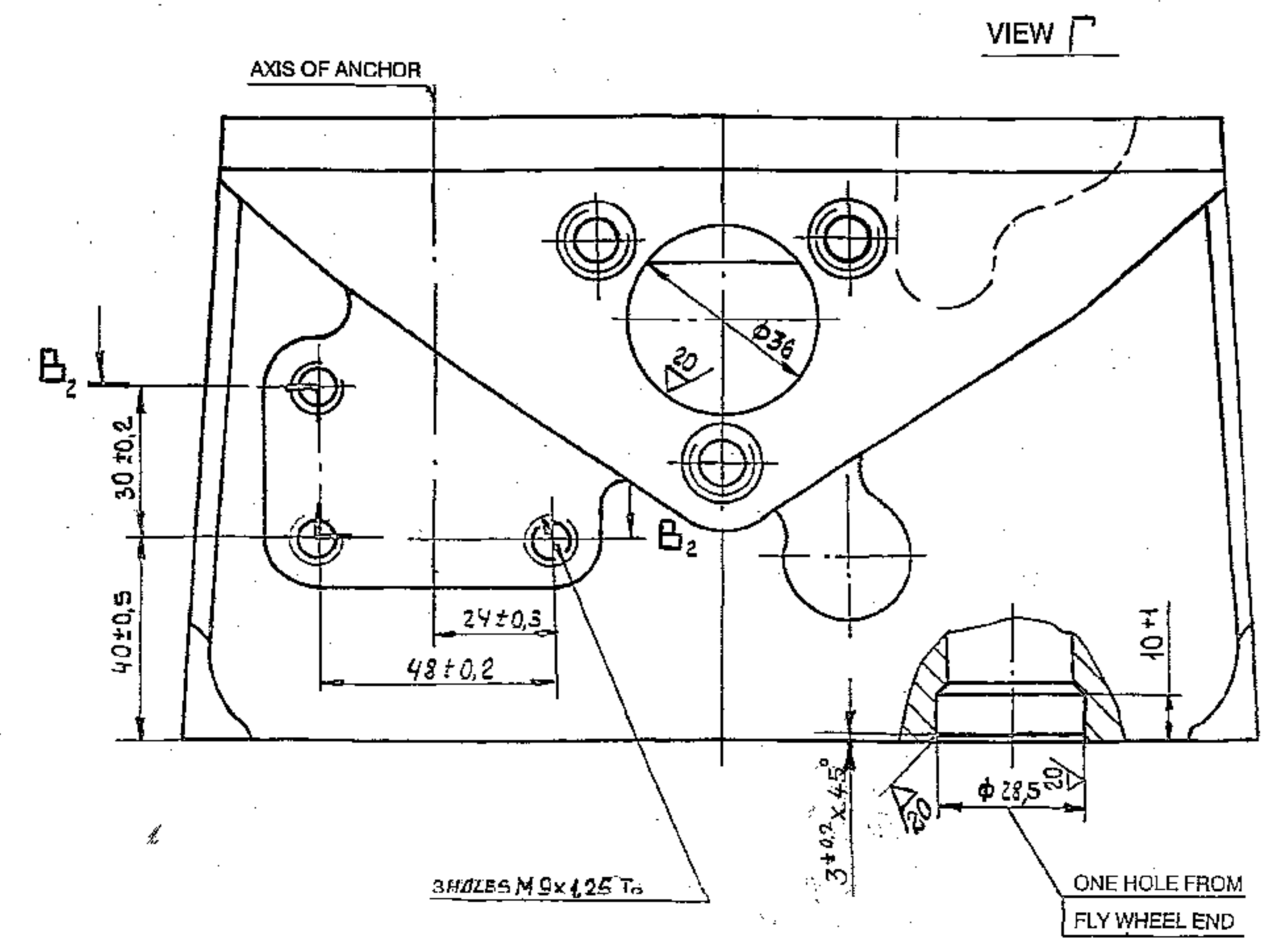

LH CYLINDER HEAD

1. Nicks, Marks and other surfaces, trimming and flay marks from machining are not allowed on the packing surface M₅.
2. Dimensions of grooves location are given for manufacturing of Tool.
3. On the exhaust side two extreme holes M8 X 1.25 T₂ are to be fulfilled.
4. Blank.
5. Blow holes, Flay marks, steps from tools and other surface defects are not allowed on surface Y₂.
6. Tool marks at a height of 60 mm from the upper surface of head is allowed in the anchor pit with oil drain hole.
7. Other dimensions, surface finish, graphics and technical requirements are as per drawing 306-16-23 (sheet 1 & 2) by taking into consideration of modification as per drawing 306-16-19.
8. Surface B₂ & M₃ should be on one plane.
9. Non perpendicularity of surface X₁ to axis of thread should not exceed 0,1 mm (dependent tolerance).

PILOT SAMPLE SHOULD BE APPROVED BY A I S P BEFORE BULK PRODUCTION.

EST. WT. (kg) TO BE STAMPED OR MARKED WHERE INDICATED THIS * (LETTERS)
36.61

ALL SHARP EDGES AND CORNERS TO BE REMOVED UNLESS OTHERWISE STATED MACHINED CORNERS TO HAVE R OUTSIDE R INSIDE EQUIVALENT CHAMFERS ARE PERMISSIBLE.

DRN	AK74(AJ19)	GOST 1588-93	USED ON: Cb 306-02-20
CHD			
APPD			
DATE	14-05-2012		CONTROLLERATE OF QUALITY ASSURANCE (HEAVY VEHICLES)
SCALE	1:1		AVADI
DIMENSIONS IN mm			TITLE: LH CYLINDER HEAD
TOLERANCE ON DIMS UNLESS OTHERWISE STATED IS: 2102-69			D S CAT NUMBER
ALL THREADS TO CONFORM TO IS: 4218, PART 4.			DRAWING NUMBER
ISSUE DATE		NATURE OF AMENDMENT	306-34-19

DRG. INDANISED BASED ON RUSSIAN ORIGINAL ISSUE - 17 AND DRG REPLACES ISSUE - B VIDE 18th BRIC PUMF No. 3

