

9 FOR CONSTRUCTION

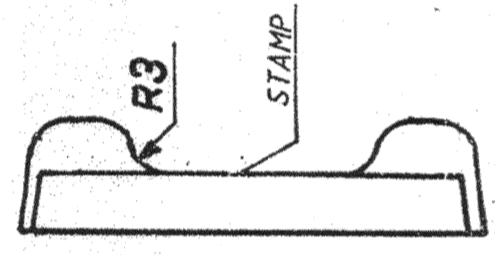
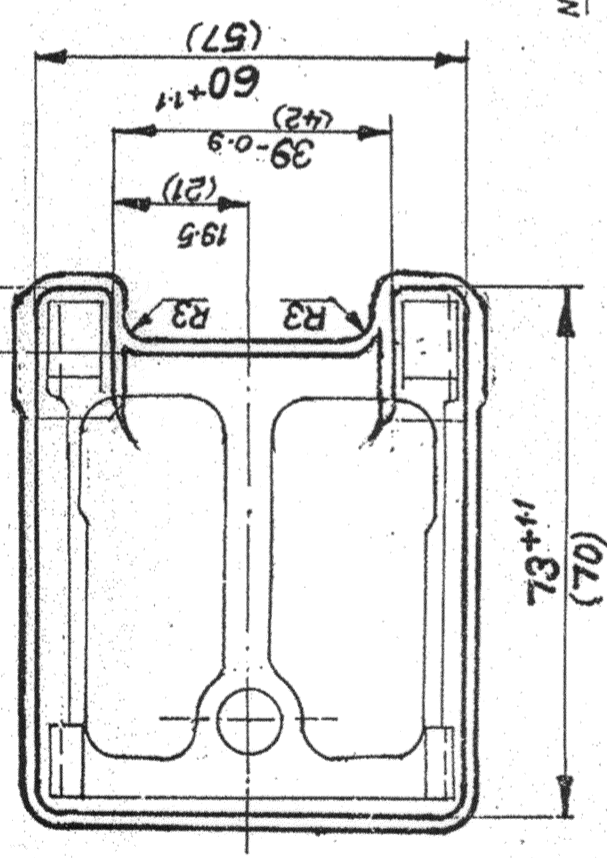

NOTES:-

1. DIMENSIONS ARE IN MM.
2. FIRST ANGLE PROJECTION.
3. SCALE:- 1:1
4. FORGING OF GROUP III AS PER GOST 8479-70, HB 217 MAX.
5. DRAFT ANGLE 7°
6. UN-SPECIFIED RADII 1.5R.
7. FLASH REMAINDER UP TO 0.6mm.
8. WARPING UP TO 0.6 mm.
9. CONVENTIONAL CONTOUR AND DIMENSIONS GIVEN IN BRACKETS PERTAIN TO THE FINISHED PART.
10. STAMP PART NO, MELT NO. AND Q.C.D STAMP
11. 100% OF A BATCH SHOULD BE CHECKED FOR HARDNESS AS PER GOST 8479-70.
12. WEIGHT OF THE FORGING 0.350 Kgs.

HEAT-TREATMENT:-FORGINGS ARE NORMALIZED AND TEMPERED.  
 FOR HEAT-TREATMENT SCHEDULE REFER DRAWING  
 NO: M 881 SHEET NO: 1 TO 3 AND SHEET NO: 6 SL.NO: 17.

MATERIAL :- STEEL 40X OST 3-98-80.  
 ALT.MATERIAL : STEEL 40 X GOST 4543-71

MATERIAL FOR INDIA : IS: 5517-1993 DESIGN 42 Cr4 Mo2 LRS 30MM  
 BS 970 PT. 1 : 1983 GR. 530 M-40 ( BS 970 : 1955 EN-18 )  
 OR  
 BS 970 PT. 1 : 1983 GR. 709 M-40 ( BS 970: 1955 EN-19 )  
 OR  
 BS 970 PT. 1 : 1983 GR. 708 M-40 ( BS 970: 1955 EN-19 A )

COMPONENT DRG. NO. 6P11-6-8  
 SLIDE FEED

DRAWING PROVISIONAL DS.CAT NO. 100500742B  
 ORDINANCE FACTORY,  
 TIRUCHIRAPALLI-16.

DIV. OFFICER

11.87

APPROVED

CHECKED

REDRAWN

VETTED FOR MATERIAL ONLY

Principal Scientific Officer,  
 Quality Assurance Officer,  
 For Senior Quality Assurance Officer,  
 Junior Quality Assurance Estt. (Arms),  
 Tiruchirappalli - 620 016.

CERTIFIED CORRECT COPY  
 OF APPROVED DRAWINGS  
 AT THIS DATE 20/10/80.  
 Design & Drawing Officer  
 Ordnance Factory,  
 Tiruchirappalli-620016

UN CONTROLLED COPY

C	004/17 Dt. 01.09.17 MATERIAL AMENDED	SIG & DATE
B	ALTERNATE MATL. EN SERIES ADDED	SIG & DATE
AMENDMENTS	DESCRIPTION/DETAILS	SIG & DATE

DRG. NO:  
 62 C 6208 200 C 3