

1	2	3	4
SS	C	A	IC
A 0 0 0	3 0 0	7 0	2 0 1

GENERAL TOL : FINE / MEDIUM / COARSE
 CLASS TO IS : 2102

DRG. CONVENTIONS CONFIRMS TO INDIAN STANDARD
 DIMENSIONS ARE IN mm UNLESS OTHERWISE STATED

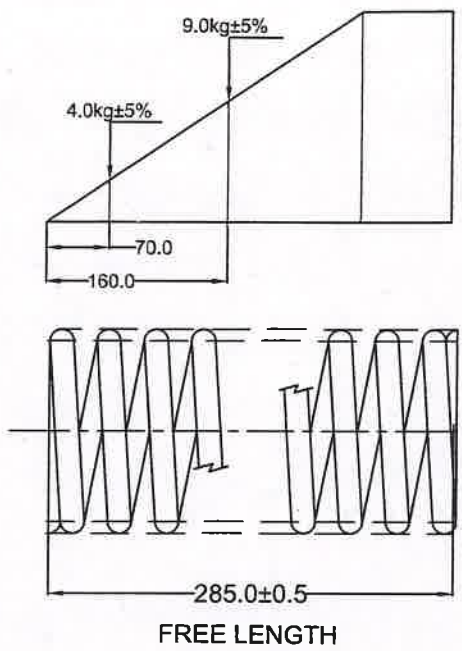

- NOTES :
- 1) STRESS TO BE RELIEVED.
 - 2) WIRE DIA : 1.4
 - 3) MEAN DIA : 10.3
 - 4) No. OF EFFECTIVE COILS : 65
 - 5) WOUND : LH OR RH
 - 6) ONE COIL OF EACH END TO BE CLOSED IN AND GROUND SQUARE TO THE AXIS OF THE COIL LEAVING 3/4 OF COIL AT EACH END NON EFFECTIVE.
 - 7) CRAMP TEST:-SPRING TO BE TESTED BEFORE GAUGING BY COMPRESSION TO SOLID LENGTH FOR A PERIOD OF 12 HOURS, AFTER WHICH IT MUST CONFORM TO FREE LENGTH.
 - 8) ALT. PROTECTIVE COATING: ELECTROLESS NICKEL-BORON NITRIDE(NiBN) COATING AS PER ARDE SPECN NO.: ARDE/SA/2016/COATING-02

CONTROLLED COPY No.: 01

Sr. No.	DATE	AUTHORITY	BRIEF RECORD	ZONE	CD	GO
					SIGN	

DRN: AMANDEEP SIGN: DATE: 24/08/2022	<i>Amandeep</i> CHECKED	MATERIAL: STEEL WIRE TO IS : 4454 Pt. 1, 2001, DH
APPD. DATE: 24/08/2022	<i>Amandeep</i> FOR DIRECTOR	PROTECTIVE FINISH: PHOSPHATED TO SPECN. IS:3618-1966, CLASS 'B'
SEALED DATE:		TITLE: SPRING RECOIL
SHEET SIZE : A4 SCALE : NTS	EST. MASS -----	
DESIGN AUTHORITY ARDE PUNE 411021		

DRG NO	2 1 0 1	0 1	0 2	0 2	0 7	0 0 3	0 0 D A
	IC	SS	*S	AA	A	C	SST

9 mm C2	PART No.	DS CAT No.	AHSP
---------	----------	------------	------