

42004
7490312603

2

THIS DOCUMENT AND THE INFORMATION CONTAINED IN IT ARE PROPRIETARY AND CONFIDENTIAL TO ODT. NO PERSON OR ENTITY IS ALLOWED TO COPY, REPRINT, REPRODUCE OR PUBLISH ANY PART OF THIS DOCUMENT, NOR DISCLOSE ITS CONTENTS TO OTHERS, NOR MAKE ANY USE OF IT, NOR ALLOW OR ASSIST OTHERS TO MAKE ANY USE OF IT UNLESS BY THE PRIOR WRITTEN EXPRESS AUTHORIZATION OF ODT AND THEN ONLY TO THE EXTENT AUTHORIZED.
COPYRIGHT-ODT.

NOTES:

1. INTERPRET THIS DRAWING IN ACCORDANCE WITH ASME Y14.100M.
2. MATERIAL: CRES BAR TYPE 17-4PH PER AMS-5643. PURCHASED IN CONDITION H1150.
3. UNLESS OTHERWISE SPECIFIED, UNDEFINED MACHINED FILLET RADI SHALL BE 0.2, 0.3
4. DEBURR AND REMOVE SHARP EDGES; APPROX. 0.2x45 Deg.
5. GENERAL TOLERANSEC ACCORDING TO ISO 2768-m.
6. PASSIVATION TREATMENT PER AMS-2700 METHOD 1 TYPE 8
7. BAKE PART AFTER PLATING WITHIN 3 HOURS PER AMS-2759/9 TABLE 1 FOR 3 HOURS MINIMUM AT 191°C.
8. QUALITY ASSURANCE PROVISIONS:
- 8.1. QUALITY ASSURANCE PROVISIONS FOR THIS ITEM PER RDMQD0012P.
- 8.2. MAJOR CHARACTERISTICS NRS 101 TO 103. PARENTHETICAL FIGURES ARE FOR REFERENCE ONLY.
9. PACKAGING AND PACKING:
10. THE FINISHED PART SHALL BE PRESERVED AND PACKAGED IN ACCORDANCE WITH MANUFACTURER'S BEST COMMERCIAL PRACTICE.
11. IDENTIFY PER MIL-STD-130 PARA 4.1.B BY LABELING ITS CONTAINER WITH THE PART NUMBER. CHARACTERS MINIMUM TEXT HEIGHT 1.25 MM.

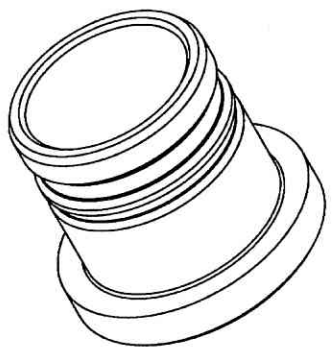

(WEIGHT: 0.022 Kg APPROX.)

2

DWC NO: 077851A-00	
SHEET REV RECORD	
ALL SHEETS ARE THE SAME REVISION	

REV	ECO	DESCRIPTION	DATE	APVD
01		Freeze	01-Dec-13	
02		Freeze	22-Apr-14	M. Levin
03		Restrict	16-Jul-14	L. Goldstein
--	T00956	Identical To Previous Released	09-Apr-18	L. Goldstein

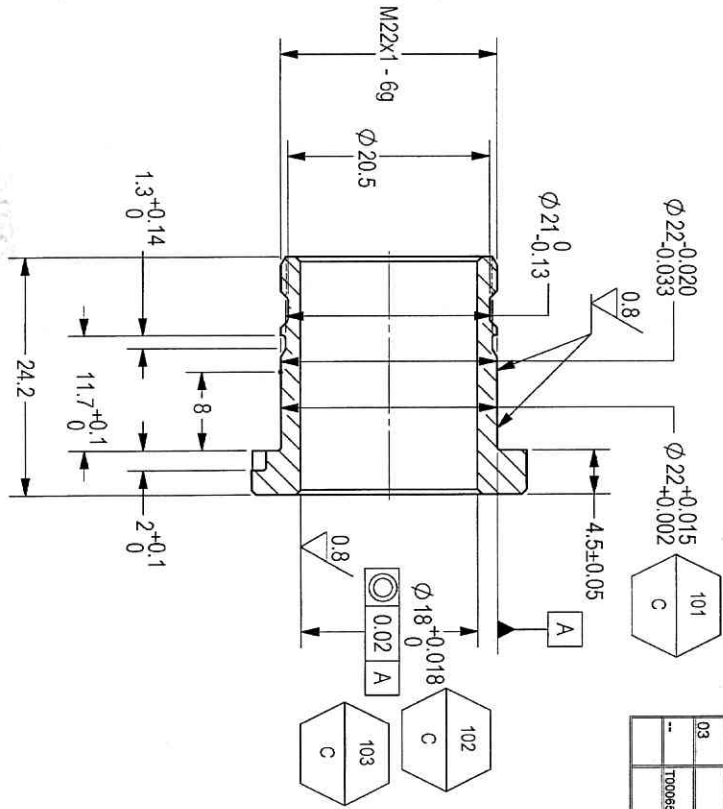

SECTION A-A

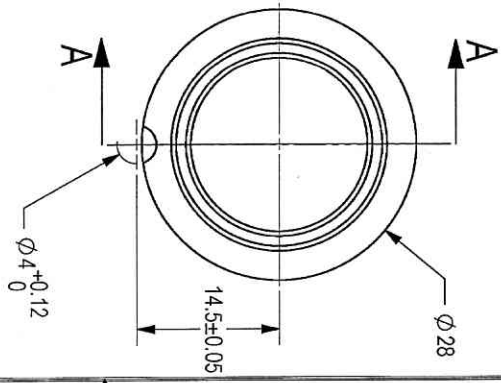

30-11-2020

1.6/0.8

SEE ATTACHED MEDIA

UNLESS OTHERWISE SPECIFIED		DIMENSIONS ARE IN MM PER ASME Y14.5M-1994		TOLERANCES		LINEAR		ANGULAR		1st ANGLE PROJECTION		SURFACE TEXTURE IN MICROMETER	
DRAWN		CHECKED		HOSJDDO		OFFICER/PRODN		OFFICER/PRODN		OFFICER/PRODN		OFFICER/PRODN	
SIGNATURE		DATE		TITLE		SIZE		CAGE CODE		DWC NO		SCALE	
DATE		TITLE		SIZE		CAGE CODE		DWC NO		SCALE		SHEET 1 OF 1	
DATE		TITLE		SIZE		CAGE CODE		DWC NO		SCALE		SHEET 1 OF 1	
DATE		TITLE		SIZE		CAGE CODE		DWC NO		SCALE		SHEET 1 OF 1	

ORDNANCE FACTORY
THIRUGHIRAPPALLI

FOR: GRADLE MOBILE
ASSY

OFF: 12.7MM SRCC

PLM Control

1

1