

SK - 6549/TE

Handwritten: Hos / mm, 13/10/15, sw

COPY No. 1

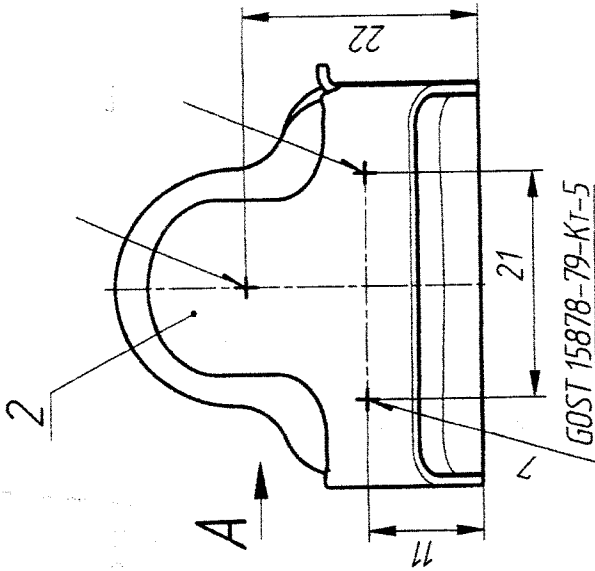
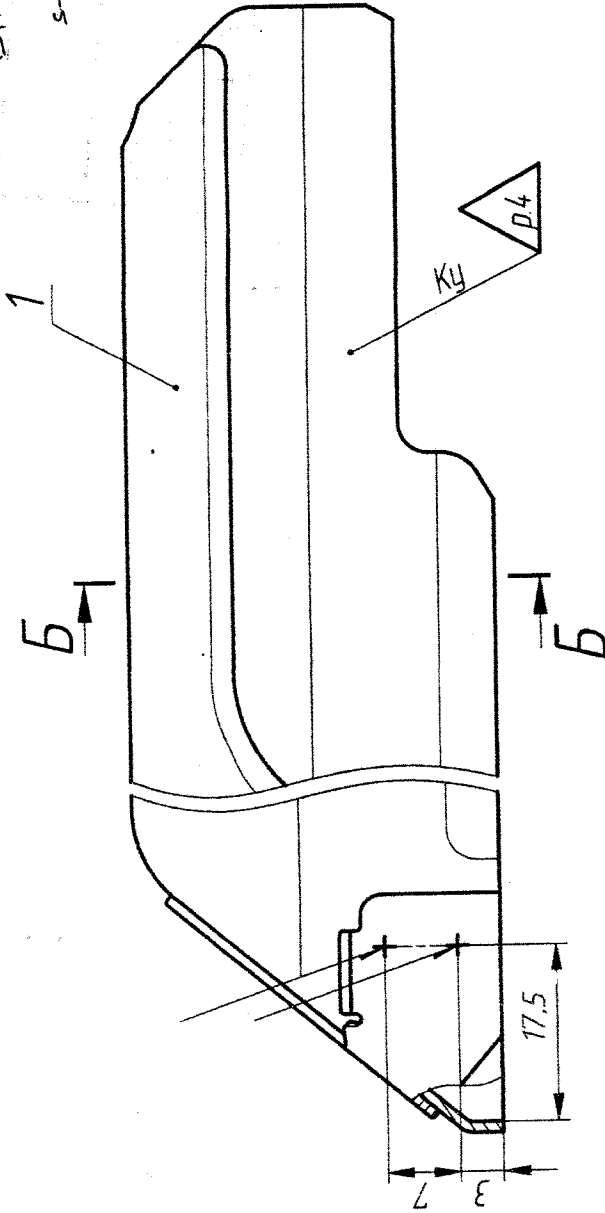

A

B-B

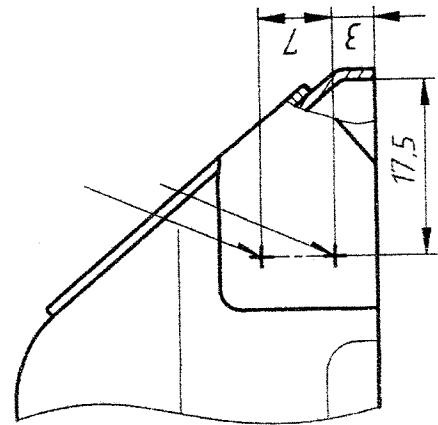
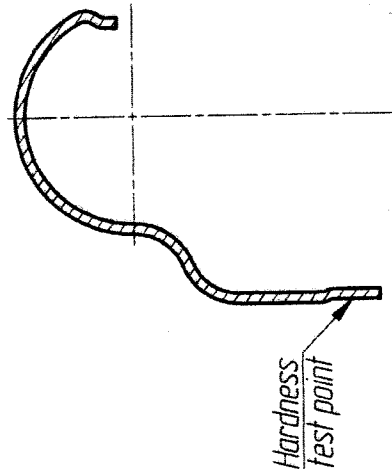

- 1 At joint heat treatment hardness of cover pos. 1 is 65..69 HRA
At hardness test point local smoothing of surface is allowed at depth up to 0,1 mm.
- 2 Heat treatment is allowed in parts cover pos. 1 and cover reinforcing plate pos. 2.
- 3 Dimensions to be ensured by tool.
- 4 Stamp according to 6П45-1СДТ4/Е2.

Weight: 0,13 g		HDS/DDC	
DRAWN	SEEN BY	CHECKED	
DATE	28/09/2023	APPROVED	
7.62x39mm AR-SAF		ORG. NO.	
Cover with reinforcing plate		SK - 6549/TE	
Assembly drawing		SHT. 1 OF 1	
SMALL ARMS FACTORY KANPUR			
SCALE	NTS		

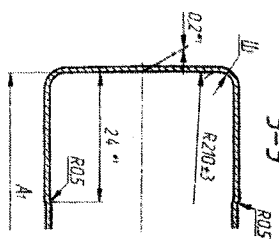
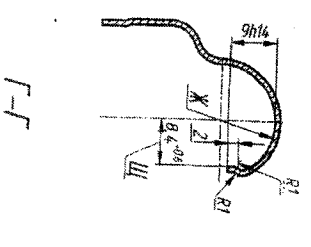
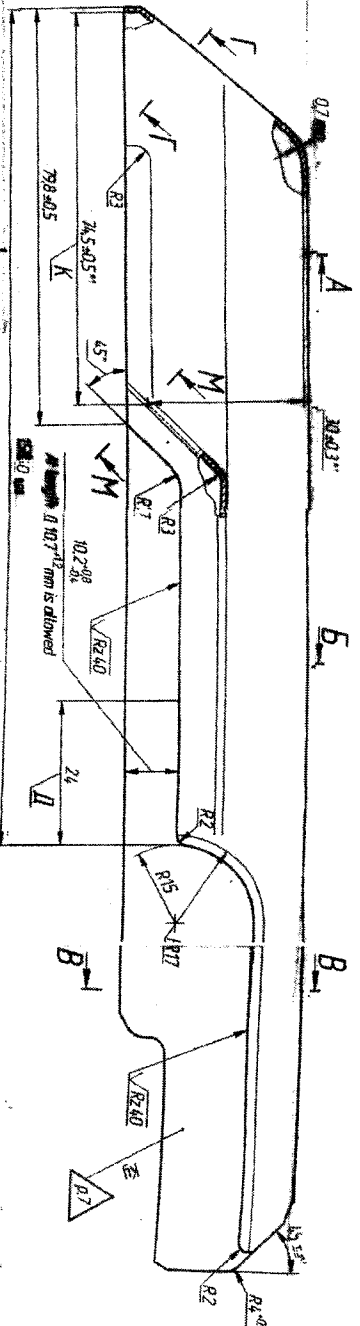
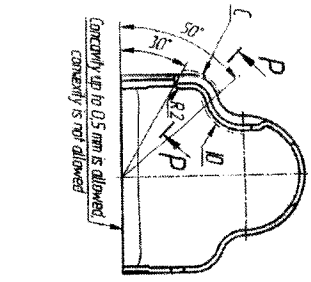
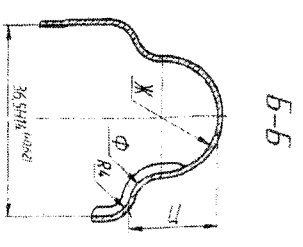
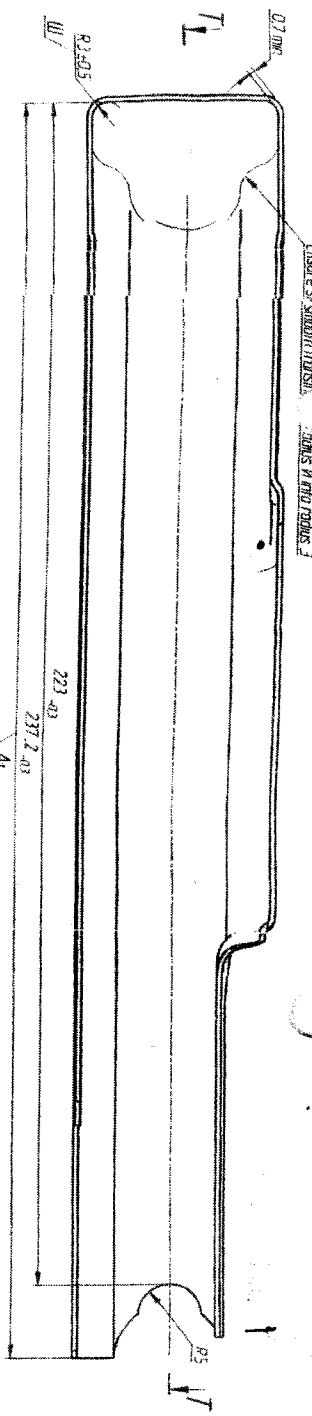
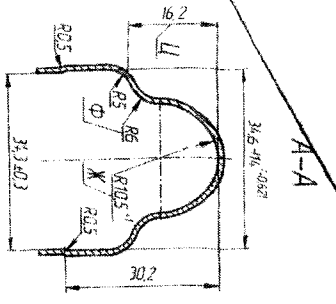

Order of rolling
of this part
is as follows
T-T
Y-Y
A-A
B-B
M-M
P-P

Rolling direction

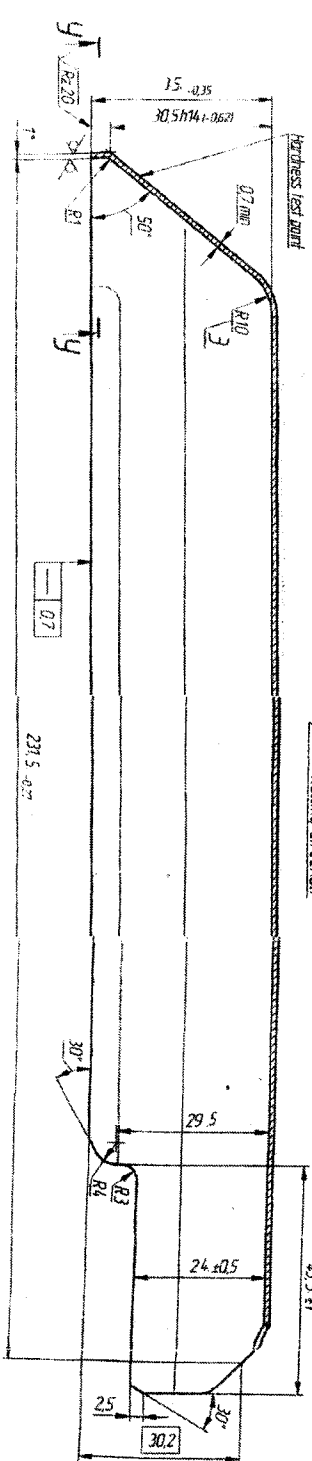
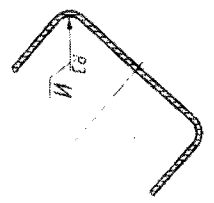
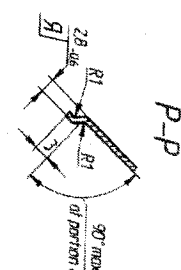
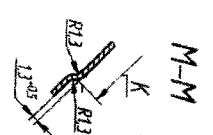

- 1 65-69 HRC All hardness test point local smoothing of surface is allowed at depth up to 0.1 mm
- 2 Heat treatment is allowed in assembly unit 6RL5-1(67)-V/E2
- 3 Reference dimension
- 4 Dimensions to be ensured by tool
- 5 Dimensions with unspecified limit deviations according to 6RL5-1(67)/E2 are ensured by tool
- 6 All portion B ensure smooth transition from dimension R1 to dimension III
- 7 Stamp other QCD inspection according to 6RL5-1(67)/E2

Shp 20K 1690 T9 3-1003-31-92

SCALE	1:1
WEIGHT	136 g
MANUFACTURER	SMALL ARMS FACTORY
DATE	2000/03/01
APPROVED	KANPUR
DESIGNER	SK-6546/TE

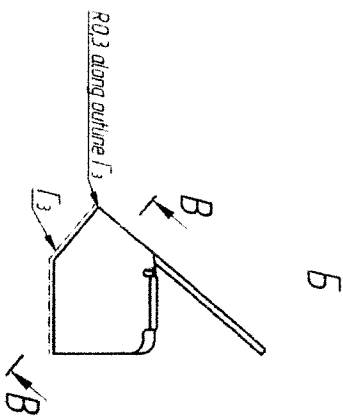
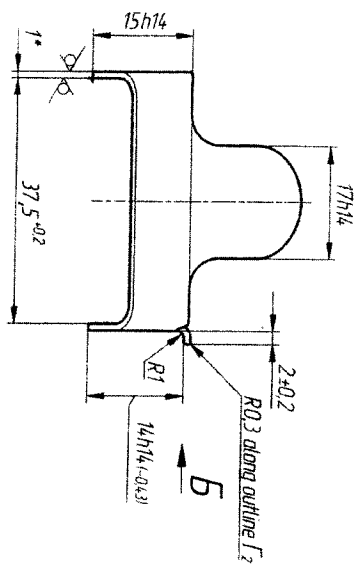
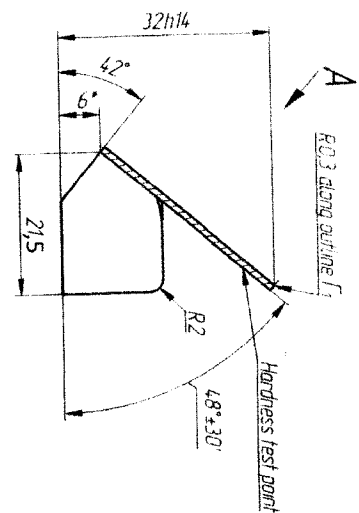

√Rz 40 (M)

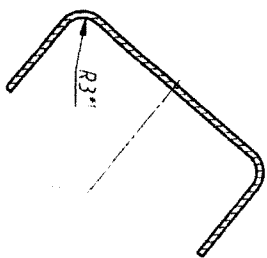
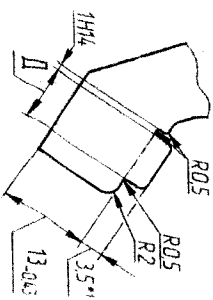
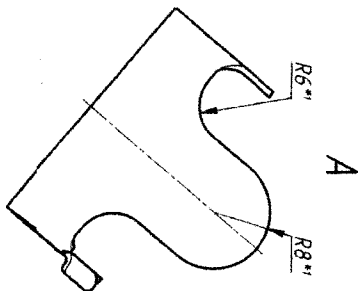
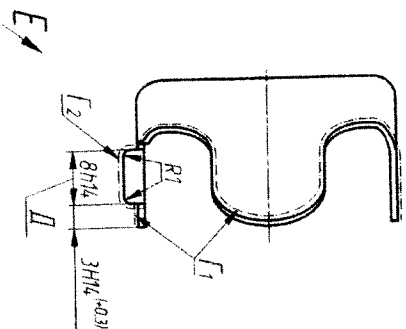

Handwritten notes: 12/10/2023, 10g, 5mm

- 1 65-69 HRA. At hardness test point local smoothing of surface is allowed at depth up to 0.1 mm.
- 2 Heat treatment is allowed in assembly unit 6745-1C87-1/E2
- 3 * Reference dimensions
- 4 ** Dimensions to be ensured by tool
- 5 Unspecified tolerances according to 6745-1C87y/E2
- 6 Bluntings are along outlines F1, F2, F3 with roughness √Rz 20
- 7 Stamp after QCD inspection according to 6745-1C87y/E2

AT-SU-51-0-1 (OST 9904-90)
Steel K49084-1-40 (OST 6523-97)

7.62x39mm AR-SAF		DRAWN		CHECKED	
Cover reinforcing plate		DATE		12/10/2023	
SMALL ARMS FACTORY		APPROVED			
KANPUR		REG. NO.		SK-6612/TE	
SCALE		SHT		1 OF 1	
NTS		HWS/DNA			
Weight: 10 g					