

SL. NO.	BRICK NO.	QUANTITY
01	717	1000 NOS.
02	718	070 NOS.
03	720	024 NOS.
04	721	020 NOS.
05	722/1	010 NOS.
06	723/1	009 NOS.
07	724	020 NOS.
08	725	111 NOS.
09	727	200 NOS.
10	728	050 NOS.

DETAIL OF BRICKS

PLAN

BRICK SPECIFICATIONS

TYPE OF BRICKS : AL-70
 AL₂O₃ : 70.0% MIN.
 Fe₂O₃ : 03.0% MAX.
 P.C.E. : 37 FOR TON CONE MIN.
 APP. POROSITY : 23% MAX.
 BULK DENSITY : 2.5 gms./C.C. MIN.
 C.C.S. : 400 Kgs./CM² MIN.
 P.L.C. : 3.5% MAX. AT 1600°/HR.



ALL DIMENSIONS ARE IN MM

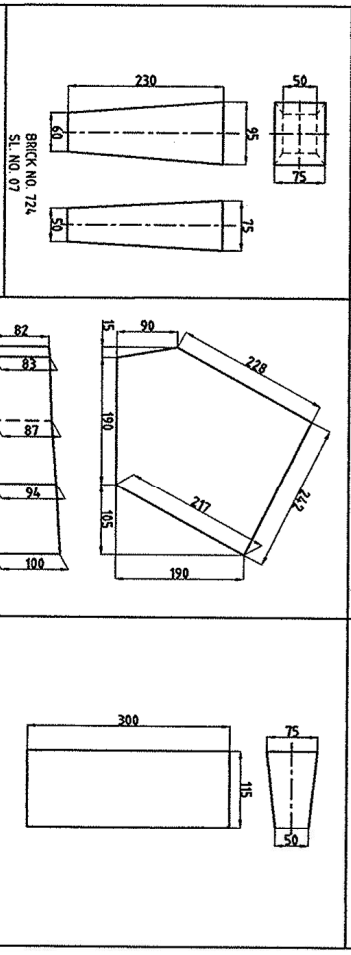
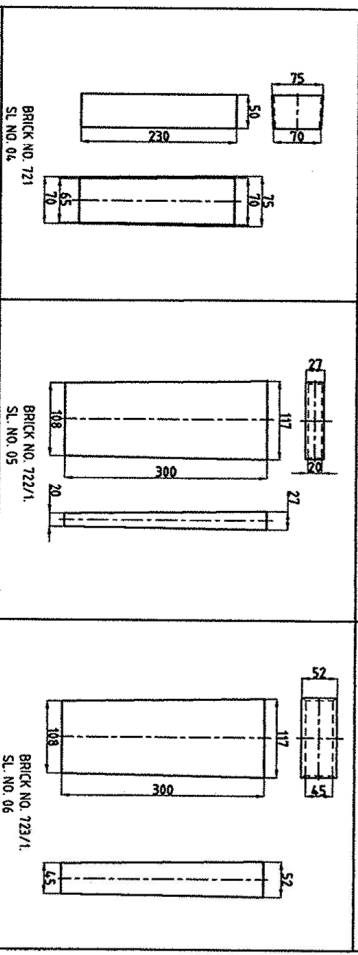
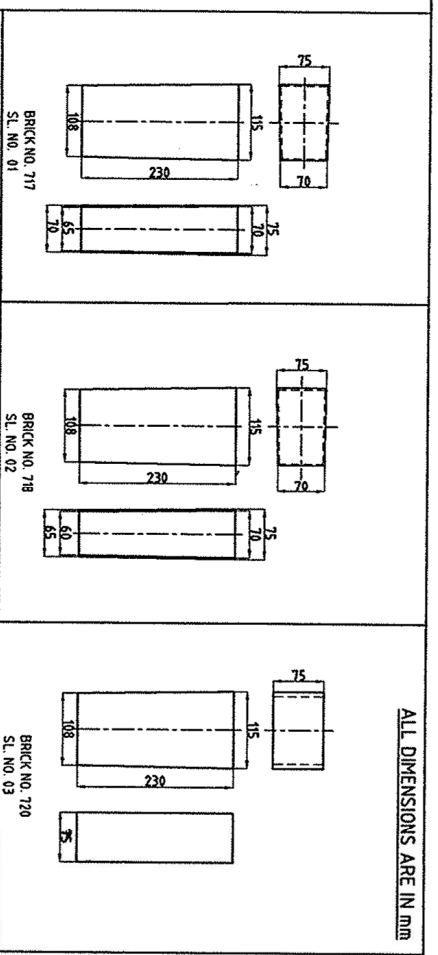

ITEM NO.	DESCRIPTION	NO. OFF.	MATERIAL	HARDNESS	REMARKS
1	QUANTITY OF BRICKS AMENDED. REF. MEMO NO. 15/ARCT/1000/28 DT. 17-8-2011				
2	AMENDMENTS				
3	INDEX				
4	ROUGHING				
5	CLEANING				
6	FINISHING				

ELECTRIC ARC FURNACE		DATE	17/8/2011
ROOF LINING		NAME	
TYPE SSKD 340		SNP	
SCALE	DRYAN	DATE	0.05/99
NTS	TRAINED	DATE	
CHECKED	APPROVED	DATE	
DATE	DATE	DATE	

MEMO NO. SHR/09-10/LOCAL DT. 03.3.09	DRG. NO. 15/ARCT/1000/28
METAL & STEEL FACTORY, ISHAPORE	