

मूल प्रति
MASTER COPY

SPECIFICATION No. IND/TC/2694
DRW SHEETS ATTACHED-16

Scaled vide
DC No. 2599-TC
17.10.13

GOVERNMENT OF INDIA
MINISTRY OF DEFENCE
DGQA ORGANISATION

**SPECIFICATION
FOR**

EQUIPMENT CARGO AERIAL DELIVERY PARACHUTE SUPPLY
DROPPING 8.5M MADE WITH BLENDED FABRIC POLYESTER &
COTTON (67:33) AND 100% POLYESTER TAPES COMPLETE WITH PACK
(CAT/PART No. - NIV)

&

EQUIPMENT CARGO AERIAL DELIVERY PARACHUTE SUPPLY
DROPPING 8.5M MADE WITH BLENDED FABRIC POLYESTER &
COTTON (67:33) AND 100% POLYESTER TAPES PACK COVER CANVAS
(350x350x320) mm (CAT/PART No. - A-4/1670-000109).

1. THIS SPECIFICATION IS INTENDED TO GUIDE PURCHASE, INSPECTION AND MANUFACTURE OF STORES AGAINST DEFENCE REQUIREMENTS.
2. IN CASE OF DISCREPANCY BETWEEN THIS SPECIFICATION AND ANY SAMPLE OR PATTERN, THIS SPECIFICATION TOGETHER WITH DRAWING SHALL BE TAKEN AS CORRECT.
3. WHEREVER A REFERENCE TO ANY OTHER SPECIFICATION/DRAWING OCCURS IN THIS SPECIFICATION, IT SHALL BE TAKEN AS REFERENCE TO THE LATEST VERSION OF THAT SPECIFICATION/DRAWING EXISTING AT THE TIME OF FINALISATION OF CONTRACT.

ISSUED BY

CONTROLLER
CONTROLLERATE OF QUALITY ASSURANCE
TEXTILES AND CLOTHING
POST BOX No. 294
KANPUR 208 004

YEAR: 2013

PRICE: Rs.



मूल प्रति
MASTER COPY

SPECIFICATION No. IND/TC/2694

RECORD OF AMENDMENTS

Amendment		Amendment Pertains to S.No. /Para No./Coloumn No.	Authority	Amended By Name & Appointment (IN BLOCK LETTERS)	Sign & Date
No.	Date				



मूल प्रति
MASTER COPY

SPECIFICATION No. IND/TC/2694

Sl. No.	CONTENTS	PAGE No.
1	FOREWARD	1
2.	SCOPE	2
3.	RELATED SPECIFICATION/REFERENCES,	3
4.	STANDARD PATTERN	4
5.	MATERIALS	4
6.	MANUFACTURE & CANOPY	5
7.	RIGGING LINES	5
8.	CANOPY STABILISERS	5
9.	PACK COVER WITH STOWAGE LOOPS	6
10.	GENERAL WORKMANSHIP AND FINISH	6
11.	REQUIREMENTS AND TESTS	7
12.	MARKING OF STORE (CANOPY)	7
13.	PACK & PARACHUTE COMPLETE WITH PACK	7
14.	PRE-INSPECTION OF SUPPLIES BY PRODUCER	8
15.	INSPECTION	8
16.	PACKAGING	9
17.	APPENDIX 'A' BASIC MATERIAL	10
18.	APPENDIX 'B' BASIC MATERIAL	11
19.	DRAWING PLATES ATTACHED	1 to 16

मूल प्रति
MASTER COPY

SPECIFICATION No. IND/TC/2694

0.0 **FOREWORD**

- 0.1 This departmental specification No. IND/TC/2694 has been prepared by Controllerate of Quality Assurance (Textiles and Clothing), Kanpur on behalf of the Director General Quality Assurance, Ministry of Defence, New Delhi-110011.
- 0.2 This specification supersedes Provisional Specn No.IND/TC/2684(a).
- 0.3 This specn. or any pattern, drg or other information issued in connection therewith, should only be used, for specific enquiries, tender or orders placed by a competent authority under Min of Def and must not be used for any other purposes whatsoever, without the sanction of the DGQA, Min of Def, Govt of India,
- 0.4 Quality assurance authority for this store is The Controller, Controllerate of Quality Assurance (Textiles & Clothing), P.B. No. 294, Kanpur 208004.
- 0.5 Enquiries relating this specification drawings or samples should be referred to the Controller, Controllerate of Quality Assurance (Textiles & Clothing), P.B. No. 294, Kanpur 208004, or the QA officer duly authorized to act on his behalf.
- 0.6 Copies of any reference documents such as specn/ drg / instruction/ guides can be obtained from C Q A(T& C), P.B. No. 294, Kanpur 208004,
- 0.7 In case of discrepancy between this specification and any sample or pattern, this specification together with drawings if any will be taken as correct.
- 0.8 Wherever a reference to any other specn/drawing occurs in this specification it shall be taken as reference to the latest version of that specification/ drawing.
- 0.9 All clauses in this specification shall be complied with in every respect irrespective of the source of supply of the materials and or components.

Copies of this specification may be obtained on payments from

The Controller
Controllerate of Quality Assurance
(Textiles and Clothing), Kanpur -208004
or

The Director
The Directorate of Standardisation
Ministry of Defence, Government of India,
'H' Block, Nirman Bhawan PO,
New Delhi -110011

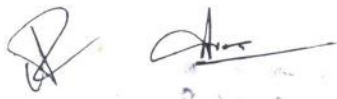

मूल प्रति
MASTER COPY

SPECIFICATION No. IND/TC/2694

1.0 SCOPE

1.1 This Specification covers the requirements of the following stores:-

i) NIV- EQUIPMENT CARGO AERIAL DELIVERY PARACHUTE SUPPLY DROPPING 8.5M MADE WITH BLENDED FABRIC POLYESTER & COTTON (67:33) AND 100% POLYESTER TAPES COMPLETE WITH PACK.

ii) CAT/PART No. A/4 1670-000109 EQUIPMENT CARGO AERIAL DELIVERY PARACHUTE SUPPLY DROPPING 8.5M MADE WITH BLENDED FABRIC POLYESTER & COTTON (67:33) AND 100% POLYESTER TAPES PACK COVER CANVAS.

1.2 The Parachute is used for dropping of supplies with one container canvas type SDM or with two container canvas type SDB. This Parachute is also used in cluster of two for heavy supplies dropping loads. A single Parachute can be used for dropping the supplies from 135 Kg to 160 Kg.

1.3 Pack cover Canvas is used for packing of the ECAD Parachute SD 8.5 m made with blended fabric polyester & cotton (67:33) and 100% Polyester Tapes.

मूल प्रति
MASTER COPY

SPECIFICATION No. IND/TC/2694

2.0 **RELATED SPECIFICATION :**

2.1 Reference is made in this specification:-

S.No	Specification	Material Particulars
a)	IND/TC/0296(b)	Sewing thread spun polyester 250 dtex x 3 OG
b)	JSS 4020-09-2013	Cordage Nylon 1785N BL White
c)	IS:2422:1985	Cotton Fabric 375g OG water repellent 75 cm wide
d)	IND/TC-2562	Fabric 410gsm, OG water proof PV Dope dyed Rip Stop 148 cm
e)	JSS 1670-03-2011	Triangular 'D' Ring Cargo Parachutes
f)	IND/GS/1534(except width)	Tape adhesive film 13mm
g)	IND/GS/1537(g)	ECAD box CAD Corrugated Card Board Boxes (380x380x445)mm
h)	JSS 8135-10-2004	Polypropylene trappings 12mm
i)	IS:4356:1967	Paper cuttings
j)	IS:2508:1984	Low density polyethylene film
k)	IS:1912:1984	Country Jute Twine
l)	IS:1397:1990 & supplementary schedule No. CQA(GS)/SS/41	Kraft paper

All specification/drawing referred to in this specification for any tender or contract shall mean the current on the date of such tender or contract.

2.2 Indian Standard Specifications are issued by the Bureau of Indian Standard and are obtained on payment from Sales Section, Bureau of Indian Standard, Manak Bhawan, 9-Bahadur Shah Zafar Marg, New Delhi-02 or their regional offices.

2.3 IND/TC series of specifications may be obtained against payment from The Controller, Controllerate of Quality Assurance (Textiles and Clothing), Post Box No. 294, Kanpur-208004.

मूल प्रति
MASTER COPY

SPECIFICATION No. IND/TC/2694

2.5 Copies of JSS specifications may be obtained from The Director, Directorate of Standardisation, Ministry of Defence, Standardisation Documentation Center, 'J' Block, Room No. 05, Nirman Bhawan PO, New Delhi-11011 on payment.

3.0 **STANDARD PATTERN**

3.1 The standard pattern of ECAD Parachute supply drop 8.5 M made with blended fabric polyester & cotton (67:33) and 100% polyester tapes with pack cover held in the custody of the Controller, Controllerate of Quality Assurance (T&C), Post Box No. 294, Kanpur shall constitute the standard as regards any particulars / properties not noted / defined in this specification.

4.0 **MATERIALS**

4.1 The Parachute with pack cover shall be manufactured from the following materials :

Sl. No.	MATERIALS	PARTICULARS
(a)	Blended fabric polyester & cotton (67:33)	As per Appendix 'A' Composition – IS:3416
(b)	Sewing thread spun polyester 250d tex x 3 OG	IND/TC/0296(b)
(c)	100% polyester Tape 25 mm	As per Appendix 'B'
(d)	100% polyester Tape 12.7 mm	As per Appendix 'B'
(e)	Cordage Nylon 1785N BL white	JSS 4020-09
(f)	"Cotton Fabric 375g OG water repellent 7 5 cm wide". *Alternate "Fabric 410gsm, OG water proof PV Dope dyed Rip Stop 148 cm".	IS:2422 *IND /TC-2562
(g)	Triangular 'D' Ring Cargo Parachute	JSS 1670-03
(h)	Tape adhesive film 13mm	IND/GS/1534(except width)

मूल प्रति
MASTER COPY

SPECIFICATION No. IND/TC/2694

5.0 MANUFACTURE

5.1 The Parachute consists of a flat, fully rigged Canopy and a Pack Cover.

5.2 CANOPY

5.2.1 The canopy shall be constructed from 28 gores sewn together longitudinally, and the seam so formed is called main seam. Each gore is in turn made up of bias cut panels. The panels are cut from blended fabric polyester & cotton (67:33) scoured and stitched together horizontally, the seams thus formed are known as cross seams form a zig-zag pattern round the canopy. The skirt diameter shall be 8.5 m and the vent dia, shall be 61 cm. The length of canopy from vent to the periphery shall be 427cm shown in the plate attached to this specification.

5.3 RIGGING LINES

5.3.1 The Canopy is rigged by means of fourteen nylon cordage 1785 N forming 28 ends. Each line shall enter the main tunnel at the periphery, goes over to the vent, crosses the vent and comes down to the periphery through the main seam in a diametrically opposite direction. The lines shall be stitched at both the periphery and vent hem. The lines are reinforced at each Rigging point by 12.7 mm polyester tape. The tape is wrapped round the lines just below the periphery and sewn to it. The length of the line inside the main seam shall be 394 cm, and across the vent shall be 53 cm.

5.3.2 The 28 rigging lines shall be divided in to two groups of 14 each (rigging lines attached with gore No. 1 to 14 in one group and 15 to 28 with other group). Each group shall then be attached to a triangular 'D' ring separately. The length of the line from the periphery to the 'D' ring attachment shall be 7.83 meter.

5.4 CANOPY STABILISERS

5.4.1 To render the Parachute stable during descent, and allow extra air entrapped inside to spill out, the canopy shall be provided with four stabilizing gaps. These gaps shall be at gores No. 1,8,15 and 22. The stabilizing gaps shall be formed by the exclusion of part panels A & B above the periphery. The gaps assume the appearance of a trapezium of size 92 cm x 46 cm.



5.5 PACK COVER WITH STOWAGE LOOPS

5.5.1 The pack cover consist of a main body made from a single piece of Cotton fabric 375gm OG, water repellent/*Alternate **Fabric 410gsm, OG water proof PV Dope dyed Rip Stop 148 cm,** having four triangular flaps on the top. Each flap is fitted with a bucket at the apex for closing the mouth of the pack by means of breaking cord. The pack shall measure 35cm x 35cm x 32 cm.

5.5.2 There is a slot at the center of the base for the metal fittings of the canopy to protrude through, for one point rig or load attachment.

5.5.3 There are four slots on the body walls immediately above the base. These slots are used for two point rig /load attachment, in which case the metal fittings protrude through two opposite slots. The slots are reinforced with polyester tapes at its circumference and the slots shall measure 4 cm x 4 cm.

5.5.4 Four loops made of nylon cordage 1785N are provided along with the four slots. In addition to loops, four length of the cordage or tape polyester 25 mm are provided suspending from the center top of the main body to draw the loops by pulling and compress the pack after packing.

5.5.5 Four tie down tapes are also provided at four corners for tying the parachute to loads so as to arrest its relative movement inside the aircraft during flight. These tapes are stitched from inside of the central base slot the corners and the free ends measuring 300 mm each protrude at the corners. The free ends of all the four tie down tapes shall be heat sealed to avoid fraying.

6.0 DIMENSIONS

6.1 The ECAD Parachute supply dropping 8.5 m made from Blended fabric polyester & cotton (67:33) and its Pack cover shall strictly conform to the shape, design and dimensions as shown in the drawing plate attached to this specification.

7.0 GENERAL WORKMANSHIP AND FINISH

7.1 In appearance, general workmanship, finish and in all other respect not noted / defined in this specification. The ECAD Parachute supply dropping 8.5 m made from Blended fabric polyester & cotton (67:33) complete with Pack shall

मूल प्रति
MASTER COPY

SPECIFICATION No. IND/TC/2694

8.0 **REQUIREMENT AND TESTS**

8.1 The materials used in the manufacture of ECAD Parachute supply dropping 8.5m made from Blended fabric polyester & cotton (67:33) complete with Pack shall be tested to their relevant particulars as mentioned in clause 4.

9.0 **MARKING**

9.1 **CANOPY**

9.2.1 Each gore at the periphery hem shall be stamped with the gore number on the right hand side and outer portion of the canopy.

9.2.1 A printed cloth size label measuring 20 cm x 2.5 cm shall be sewn to the periphery of gore number one. The label shall be legibly and indelibly marked with stamping ink with the nomenclature and Cat/Part No. of the store, manufacturer's name of recognized trade mark and month & year of manufacture.

10.0 **PACK & PARACHUTE COMPLETE WITH PACK**

10.1 A printed cloth size label measuring 125 mm x 75 mm each for the pack and the parachute complete with pack shall be sewn to the center of the inner side of the upper flap and on the outer side of the side wall respectively showing the following details.

- (a) Name & Trade mark of the Manufacturer.
- (b) Cat/Part No. & Nomenclature of the store.
- (c) Month and year of manufacture.
- (d) S.No. of the Pack.

11.0 **PRE- INSPECTION**

11.1 Manufacturers / Contractors must satisfy themselves first that the store manufactured are in accordance with the terms of the contract and fully conform to the required specification by carrying out a thorough, pre-inspection of each lot / batch before actually tendering the same for inspection to the Quality Assurance Officer nominated under the terms of the contract. A declaration by the contractor that necessary pre-inspection / tests has been carried out on the stores tendered and the same are fit for inspection and tests carried out shall be rendered along with the challan. The declaration shall also include the method followed in carrying out pre-



मूल प्रति
MASTER COPY

SPECIFICATION No. IND/TC/2694

inspection showing the features checked / tested and the test reports /certificate will be submitted along with challan / declaration.

11.2 If the Quality Assurance officer finds that pre-inspection of the consignment as required above has not been carried out, the consignment is liable for rejection.

12.0 INSPECTION

12.1 100% supply shall be visually inspected for appearance, shape design, workmanship and finish 10% supply shall be checked for dimensions.

12.2 The stores which are not found conforming to this specn shall be rejected.

13.0 PACKING

13.1 Parachute being a critical and costly items/equipment in the service stores, its packing should be carried out with the attention and care to avoid the risk of any damage during packing, transit and storage thereby rendering the store unserviceable.

13.2 The following materials shall be used in the packing of ECAD Parachute supply dropping 8.5m made with blended fabric Poly & cotton (67:33) and 100% polyester tapes complete with pack.

SNo.	MATERIALS	PARTICULARS
(i)	Low density Polyethylene film 0.04 mm or Polypropylene film 0.375 mm	IS: 2508 or Best trade Quality approved by the QA Authority
(ii)	Kraft Paper	IS: 1397
(iii)	Twine Jute 3 ply	IS: 1912
(iv)	Paper wrapping cutting or Any other stuffing/cushioning material	IS: 4356 or Best trade Quality approved by the QA Authority
(v)	ECAD Corrugated cardboard boxes 380x380x455 mm	IND/GS/1537(g)
(vi)	Polypropylene Strapping 12 mm wide	JSS 8135-10

मूल प्रति
MASTER COPY

SPECIFICATION No. IND/TC/2694

13.3 Each Parachute complete with pack shall be placed inside a polyethylene bag, which after being properly sealed, shall be wrapped with one layer of kraft paper. The pack so formed shall then be tied with jute 3 ply to prevent the package from opening. One such unit pack shall be suitably placed inside a box corrugated cardboard.

13.4 The flaps of the boxes corrugated cardboard shall be secured by lacing jute twine 3 ply through the eyelets provided for the purpose.

13.5 The empty spaces if any, shall be filled in with cushioning material.

13.6 If ordered for delivery to a local inspection Depot, the parachutes shall be delivered loose in firm's returnable packs. After inspection, the accepted supplies shall be packed by the inspection Depot authorities as indicated in the proceeding paragraphs.

13.7 Before dispatch, each Box/ Case shall be legibly and indelibly marked showing the following details.

- a) Manufacturers name & recognized trade mark.
- b) Nomenclature of store
- c) Cat/Part No. of the store
- d) Month and year of manufacture /Packing
- e) Serial No. of the box/Case.
- f) Quantity packed in each box/case in Kg.
- g) Name & address of the Consignee.
- h) Inspection Note No. & Date.

KANPUR
DATE

The Controller
Controllerate of Quality Assurance
Textile and clothing
Post Box No.294, Kanpur-208004
E- Mail: cqatc-dgqa@nic.in

मूल प्रति
MASTER COPY

SPECIFICATION No. IND/TC/2694

Appendix 'A'

REQUIREMENT OF FABRIC BLENDED POLYESTER & COTTON (67:33)

ECAD PSD 8.5M

Parameter	Requirement (Constructional particulars of fabric)	Methods
Width (cms.)	95 or as agreed	IS: 1954
Mass (gm/sq mtr.) (Max)	130	IS:1964
* Ends / dm	330-350	IS:1963
* Picks / dm	250-270	IS:1963
*Counts of yarn (Tex)	Warp-20 Weft-20	IS:3442
Breaking Load ('Kg/N') Minimum(5x20 cm strip/grip)	Warp- 65 (635N) Weft- 55 (540N)	IS:1969
Air porosity (cu ft/sq ft/ sec)	16 ± 4	IS:11056
Composition (%) (Dry Mass Basis)	Polyester 67 ± 2 Cotton 33 ± 2	IS:3416
pH Value (Cold Method)	6.0 to 8.5	IS:1390
Water soluble matter (Max %)	1	IS:3456
Weave	Plain	Visual

* These parameters are of suggestive in nature and the manufacturer may make suitable alteration without changing the basic characteristics of the fabric, provided the fabric meets all other requirements given above.



मूल प्रति
MASTER COPY

SPECIFICATION No. IND/TC/2694

Appendix 'B'

REQUIREMENT OF 100% POLYESTER TAPES

ECAD PSD 8.5M

Parameter	25 mm Tape	12.7 mm Tape	Method
Width (mm.)	25 mm	12.7 mm	Appendix B of IS: 3846:1984
Mass (gm/ mt.)	12 (max)	8 (max)	Appendix C of IS: 3846:1984
Ends (In full width)	85+4 -0	60+3 -0	IS :1963
Picks / cm	20+2* -0	20+2* -0	IS:1963
Breaking load (20 cm X Full width) ('KN.') Minimum	2.4	1.5	IS:1969
Nature of material	100% Polyester	100% Polyester	IS:667
pH Value (Cold Method)	6 to 8.5	6.0 to 8.5	IS:1390
%Water soluble matter (max)	1 %	1 %	IS:3456
Weave	2/2 Twill weave	2/2 Twill weave	Visual

* Total picks based on two thread working as one.



मूल प्रति
MASTER COPY

DRG ATTACHED TO SPECN. No. IND/TC/2694

SHEET No.1 OF 16

EQUIPMENT CARGO AERIAL DELIVERY PARACHUTE
SUPPLY DROPPING 8.5 M MADE WITH BLENDED FABRIC
POLYESTER & COTTON (67:33) AND 100% POLYESTER TAPES
COMPLETE WITH PACK- NIV

EQUIPMENT CARGO AERIAL DELIVERY PARACHUTE SUPPLY
DROPPING 8.5 M COTTON PACK COVER CANVAS (350x350x320) mm
(Cat/Part No.A4/1670-000109)

INDEX

SHEET No.	PARTICULARS
1	INDEX
2	LIST OF MATERIAL/ METAL COMPONENTS
3	CANOPY
4	GORE SHAPE
5	TEMPLATE
6	VENT
7	VENT COLLAR
8	ENLARGEMENT OF PERIPHERY EDGE
9	METHOD OF SECURING RIGGING LINES WITH 'D RING
10	DETAIL OF PARTIAL MISSING GORE
11	DETAIL OF PARTIAL MISSING GORE INSIDE VIEW AT 'Y' (ENLARGED)
12	RIGGING LINE MARKING & CUTTING CHART
13	PACK COVER ASSEMBLY
14	DEVELOPMENT OF PACK
15	DETAIL AT 'X' (INSIDE VIEW)
16	DEVELOPMENT OF PACK COVER BOTTOM PIECE



ਮੁੱਲ ਪਤਿ
MASTER COPY

DRG ATTACHED TO SPECN. No. IND/TC/2694

SHEET No.2 OF 16

EQUIPMENT CARGO AERIAL DELIVERY PARACHUTE SUPPLY
DROPPING 8.5 M MADE WITH BLENDED FABRIC POLYESTER &
COTTON (67:33) AND 100% POLYESTER TAPES COMPLETE WITH PACK -
NIV

EQUIPMENT CARGO AERIAL DELIVERY PARACHUTE SUPPLY
DROPPING 8.5 M MADE WITH BLENDED FABRIC POLYESTER &
COTTON (67:33) AND 100% POLYESTER TAPES COMPLETE WITH PACK
COVER CANVAS (350x350x320)mm (Cat/Part No. 1670-000109)

LIST OF MATERIAL /METAL COMPONENTS

S No.	MATERIAL	SPECN.
(a)	Blended fabric polyester & cotton (67:33)	As per Appendix 'A' Attached
(b)	Sewing thread spun polyester 250 d tex x 3 OG	IND/TC/0296 (b)
(c)	100% polyester Tape 25 mm	As per Appendix 'C' Attached
(d)	100% polyester Tape 12.7 mm	As per Appendix 'C' Attached
(e)	Cordage Nylon 1785N BL white	JSS 4020-09
(f)	Cotton Fabric 375 gm OG water repellent 75 cm wide <u>*Alternate "Fabric 410gsm, OG water proof PV Dope dyed Rip Stop 148 cm</u>	IS:2422 IND /TC-2562
(g)	Triangular 'D' Ring Cargo Parachute	JSS 1670-03
(h)	Tape adhesive film 13mm	IND/GS/1534 (except width)

EQUIPMENT CARGO AERIAL DELIVERY
 PARACHUTE SUPPLY DRIPPING 8.5m
 MADE WITH BLENDED FABRIC POLYESTER & COTTON
 (67:33) AND 100% POLYESTRE TAPES
 COMPLETE WITH PACK (NIV)

CANDPY

A TOLERANCE OF 25 mm IS ALLOWED ON MACHINING OF AUXILIARY SEAMS

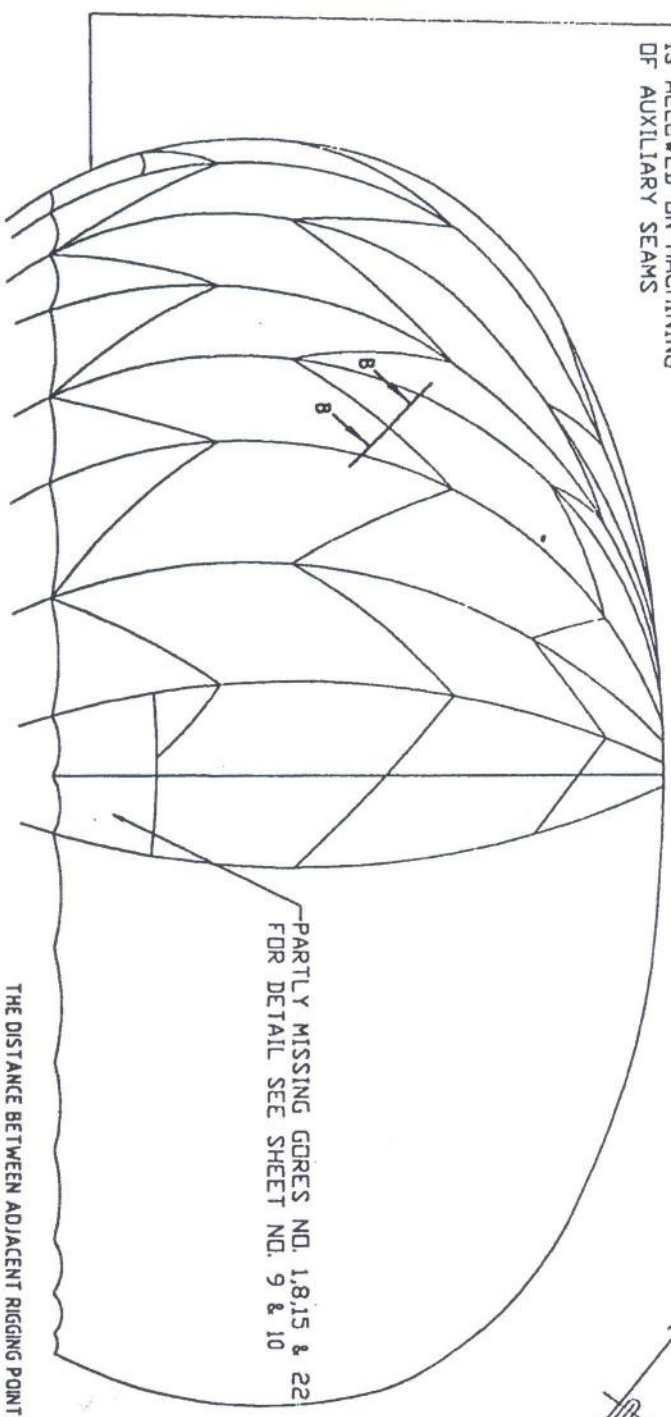

PARTLY MISSING GORES NO. 1, 8, 15 & 22 FOR DETAIL SEE SHEET NO. 9 & 10

SECTION B-B

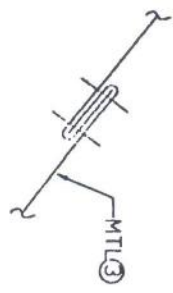

THE DISTANCE BETWEEN ADJACENT RIGGING POINTS AFTER INSERTION OF TAPE TO BE 94.0 ± 1.3/-2.5. THERE ARE 14 RIGGING LINES WHICH ARE CONTINUOUS FROM CONNECTING LINK TO CONNECTING LINK, THUS MAKING 28 LINES FROM HEM TO CONNECTING LINK. THESE ARE ARRANGED IN GROUPS, EACH OF 14 CONSECUTIVE LINES ATTACHED TO A LINK IN ANY ONE PARACHUTE NOT MORE THAN 14 GORES SHALL BE AT THE HIGH OR ALTERNATIVELY AT THE LOW TOLERANCE.

ALL DIMENSIONS ARE IN mm

	DGN	R. DRN AJAY KUMAR jto (D)
	PSD	GO-8/10
	APD	DC-8/10

मूल प्रति
MASTER COPY

मूल प्रति
MASTER COPY

DRG. ATTACHED TO SPECN. No. IND/TC/2694

SHEET NO. 4 OF 16

EQUIPMENT CARGO AERIAL DELIVERY PARACHUTE SUPPLY DROPPING 8.5 m

MADE WITH BLENDED FABRIC POLYESTER & COTTON
(67:33) AND 100 % POLYESTER TAPES
COMPLETE WITH PACK
(NIV)

GORE SHAPE

28 GORES PER PARACHUTE
INCLUDING 4 PARTLY MISSING GORES

ALLOWANCES HAS BEEN MADE
FOR MAIN SEEM AND HEM

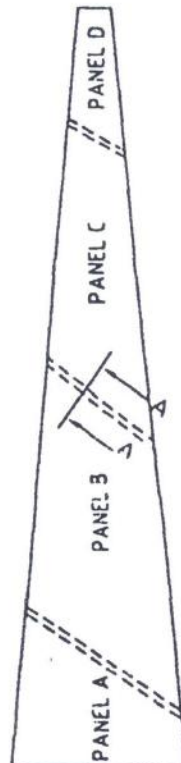

SECTION A-A (1:1)

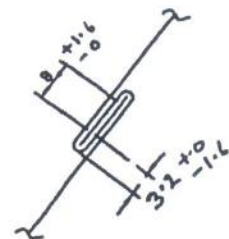

STITCHING WITH MTL ③

ALL DIMENSIONS ARE IN mm



DGN

R. DRN
AJAY KUMAR
JTO (D)

PSD.

GO-8/10

APD.

PC 2110

मूल प्रति
MASTER COPY

DRG. ATTACHED TO SPECIM No IND/FC/2694

SHEET NO. 5 OF 16

EQUIPMENT CARGO AERIAL DELIVERY PARACHUTE SUPPLY DROPPING 8.5 m

MADE WITH BLENDED FABRIC POLYESTER & COTTON
(67:33) AND 100 % POLYESTER TAPES
COMPLETE WITH PACK
(NIV)

TEMPLATE

PANELS TO BE CUT TO THIS TEMPLATE

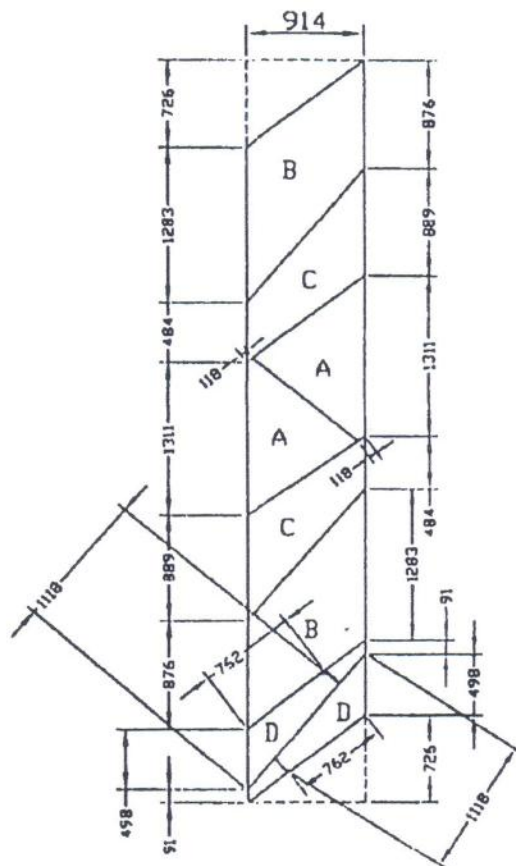

[Handwritten signature]

ALL DIMENSIONS ARE IN mm

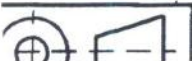

DGN

R. DRN

PSD.

APD.

मूल प्रति
MASTER COPY

DRG. ATTACHED TO SPECN. NO. IND/IC/2694

SHEET NO. 6 OF 16

EQUIPMENT CARGO AERIAL DELIVERY PARACHUTE SUPPLY DROPPING 8.5 m

MADE WITH BLENDED FABRIC POLYESTER & COTTON (67:33) AND 100 % POLYESTER TAPES
COMPLETE WITH PACK
(NIV)

VENT

THE CIRCUMFERENCE OF THE VENT BEFORE THE COLLAR IS ATTACHED MAY BE SOME WHAT LARGER THAN THE SPECIFIED VENT CIRCUMFERENCE. ANY SURPLUS FABRIC SHOULD BE EVENLY GATHERED INTO THE VENT COLLAR, SO THAT THE FINISHED SIZE IS CORRECT. THE CENTERS OF THE MAIN SEAM SHOULD CONCIIDE WITH 28 EQUIDISTANT MARKS OF THE FIRST TURN OF THE REINFORCING HEM.

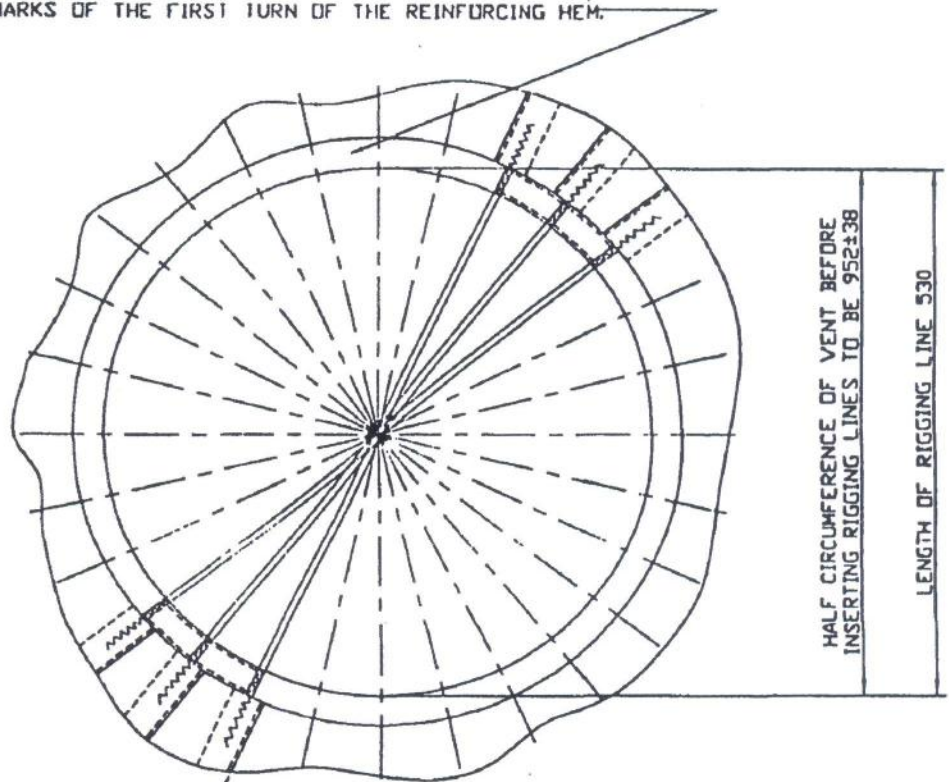

WHEN THE RIGGING LINES ARE FASTENED AT VENT & PERIPHERY & STRETCHED BY HAND TENSION, THE STRAIN SHALL NOT COME ON THE FABRIC BODY, THE LENGTH OF THE MAIN SEAM BEFORE INSERTING RIGGING LINE SHOULD BE APPROX 4270 mm.

NOTE:- TOLERANCE
IN DIMENSIONS OF
GORES' FROM
PERIPHERY TO
VENT - ± 2 cm

ALL DIMENSIONS ARE IN mm

	DGN	R. DRN AJAY KUMAR	PSD	APD.
--	-----	----------------------	-----	------

मूल प्रति
MASTER COPY

DRG. ATTACHED TO SPECN. No. IND/TC/2694

SHEET NO. 7 OF 16

EQUIPMENT CARGO AERIAL DELIVERY PARACHUTE SUPPLY DROPPING 8.5 m

MADE WITH BLENDED FABRIC POLYESTER & COTTON
(67:33) AND 100 % POLYESTER TAPES
COMPLETE WITH PACK
(NIV)

VENT COLLAR

SECTION A-A

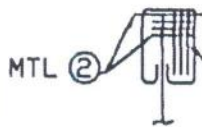

VENT REINFORCING TAPE
MTL 4 TAKEN ROUND THE
PERIPHERY 2 TIMES AND
CAPPED FOR THE WIDTH OF
ONE GORE

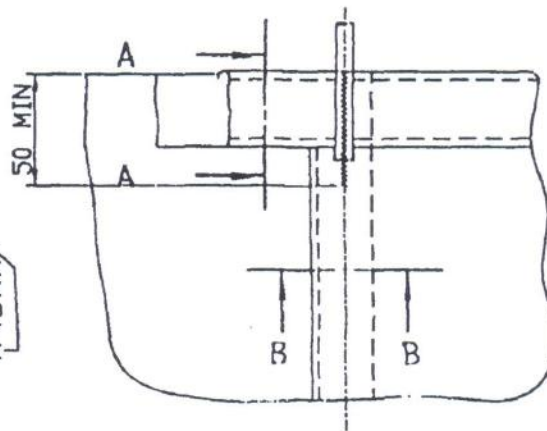

SECTION B-B

THE MAIN SEAM SHOULD BE STITCHED WITH
SLIGHTLY LESS TENSION

ALTERNATIVE VENT
FORMATION

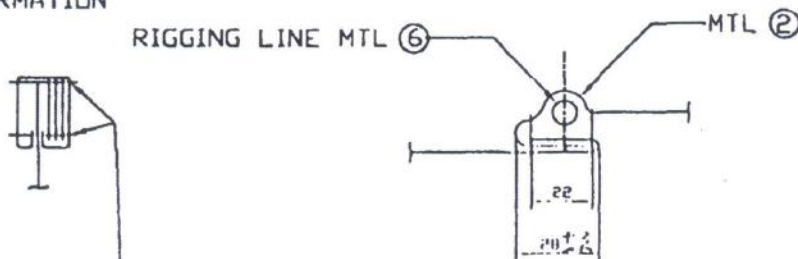

REINFORCING TAPE PREFORMED WITH
2 ROWS OF STITCHING

ALL DIMENSIONS ARE IN mm

	DGN		R. DRN		PSD.		APD.
--	-----	--	--------	--	------	--	------

मूल प्रति
MASTER COPY

DRG. ATTACHED TO SPECN. NO. IND/TC/2694

SHEET NO. 8 OF 10

EQUIPMENT CARGO AERIAL DELIVERY PARACHUTE SUPPLY DROPPING 8.5 m

MADE WITH BLENDED FABRIC POLYESTER & COTTON
(67:33) AND 100 % POLYESTER TAPE
COMPLETE WITH PACK
(NIV)

ENLARGEMENT OF PERIPHERY EDGE

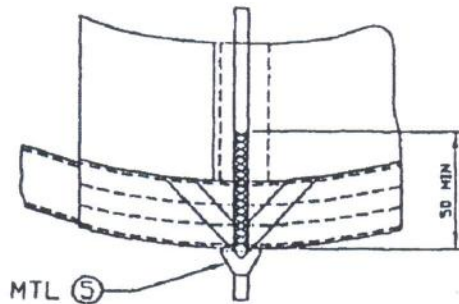

SCRAP VIEW SHOWING METHOD OF SECURING TAPE
ON INSIDE OF PARACHUTE AIR RIGGING LINE

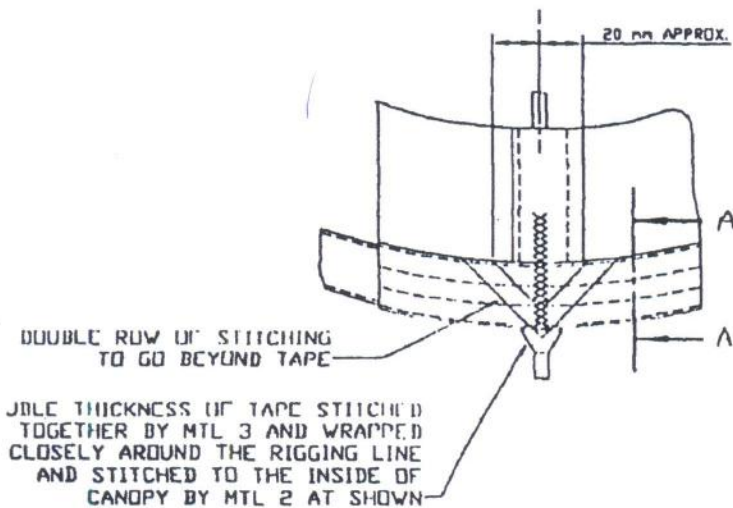

SECTION-AA

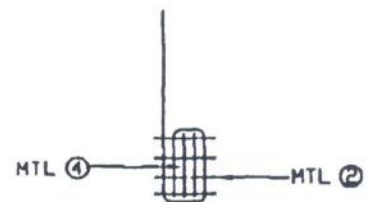

ALL DIMENSIONS ARE IN mm

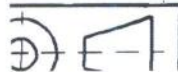

DGN

R. DRN

PSD.

APD.

AJAY KUMAR

मा १३
MASTER COPY

DRG. ATTACHED TO SPECN. No. IND/IC/269A

SHEET. NO. १ OF १६

EQUIPMENT CARGO AERIAL DELIVERY PARACHUTE SUPPLY DROPPING 8.5 m

MADE WITH BLENDED FABRIC POLYESTER & COTTON
(67:33) AND 100 % POLYESTER TAPES
COMPLETE WITH PACK
(NIV)

METHOD OF SECURING RIGGING LINES WITH 'D' RING

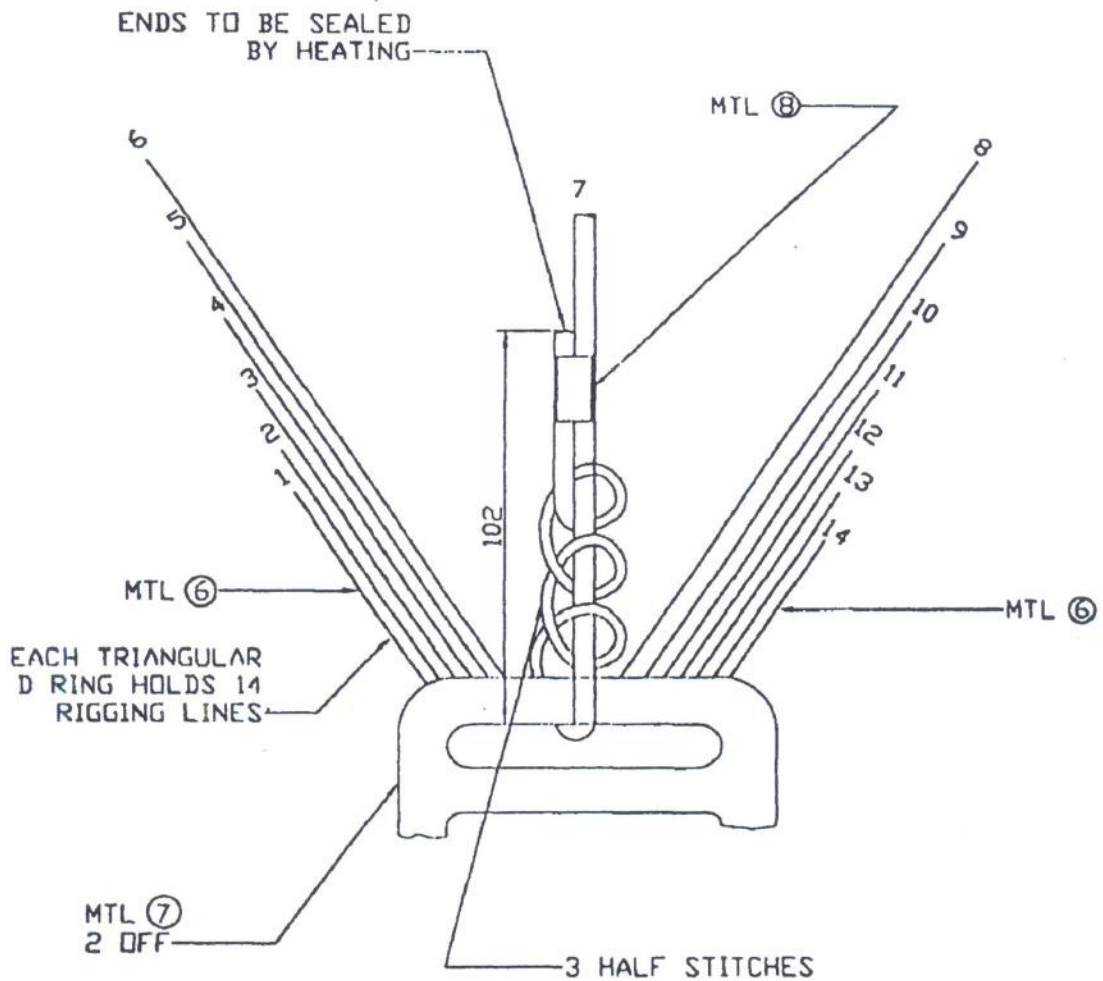

ALL DIMENSIONS ARE IN mm



DGN

R. DRN
AJAY KUMAR

PSD.

APD.

मूल प्रति
MASTER COPY

DRG. ATTACHED TO SPECN. No. IND/TC/2694

SHEET NO. 11 OF 16

EQUIPMENT CARGO AERIAL DELIVERY PARACHUTE SUPPLY DROPPING 8.5 m

MADE WITH BLENDED FABRIC POLYESTER & COTTON
(67:33) AND 100 % POLYESTER TAPES
COMPLETE WITH PACK
(NIV)

DETAIL OF PARTLY MISSING GORE
INSIDE VIEW AT 'Y'
(ENLARGED)

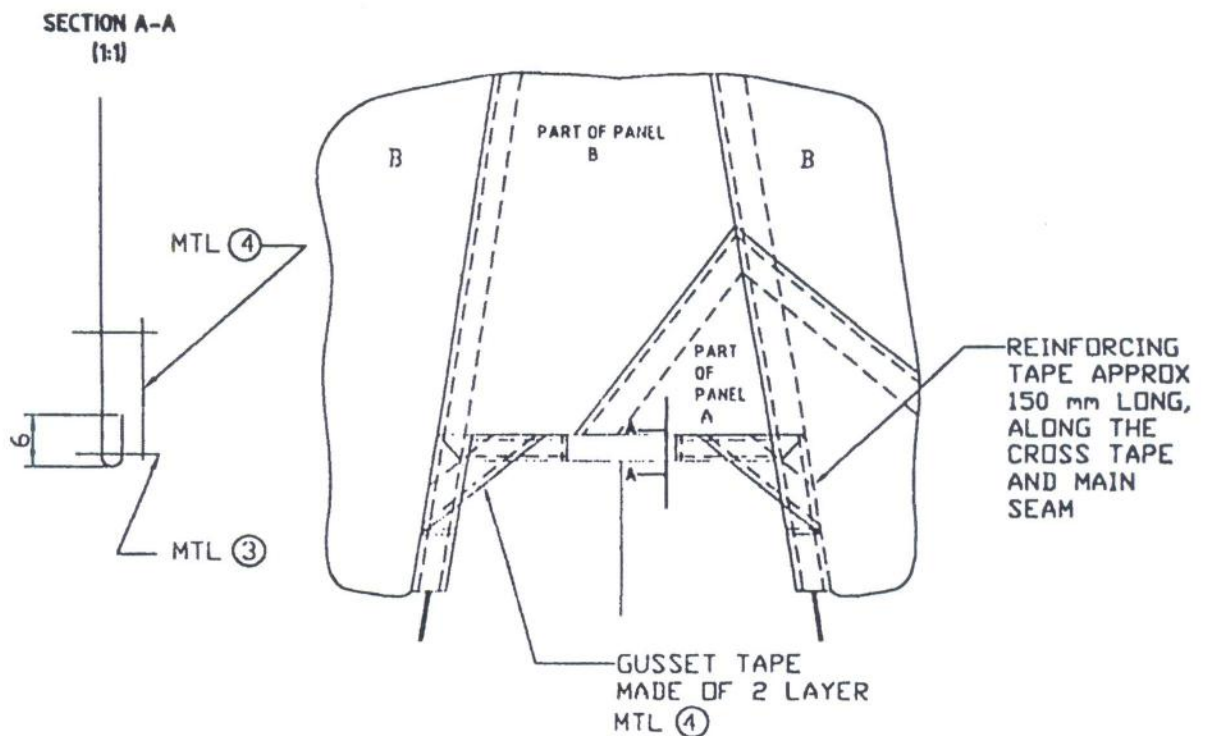

NOTE:-

WHILE STITCHING THE REINFORCING TAPE AND GUSSET TAPE, CARE SHOULD BE TAKEN THAT THE STITCHING SHOULD NOT INTERFERE THE FREE MOVEMENT OF THE RIGGING LINE INSIDE THE MAIN SEAM.

ALL DIMENSIONS ARE IN mm

	DGN	R. DRN ATAV KIMAD	PSD.	APD.
--	-----	----------------------	------	------

EQUIPMENT CARGO AERIAL DELIVERY
 PARACHUTE SUPPLY DRIPPING 8.5m
 MADE WITH BLENDED FABRIC POLYESTER & COTTON
 (67:33) AND 100% POLYESTER TAPES
 COMPLETE WITH PACK
 (NIV)

RIGGING LINE MARKING & CUTTING CHART

TYPE	MATERIAL	LENGTH TABLE CENTRE OF PULLEYS	TENSION APPLIED	DISTANCE BETWEEN MARKS ON TABLE			MINIMUM AT SCALE FOR TYING
				CENTRE PULLEY TO VENT A	VENT TO SKIRT B	VENT TO TIE DN C	
8.5-m	NYLON	12.3 - m	249.5 Kg	267 mm	3.94-m	7.83-m	20

ALL DIMENSIONS ARE IN mm

	DGN	R. DRN AJAY KUMAR JTO (D)	PSD. GO-8/10	APD. DC-8/10
--	-----	---------------------------------	-----------------	-----------------



मूल प्रति
MASTER COPY

DRG. ATTACHED TO SPECN. NO. IND/TC/2694

SHEET NO. 13 OF 16

EQUIPMENT CARGO AERIAL DELIVERY PARACHUTE SUPPLY DROPPING 8.5 m

MADE WITH BLENDED FABRIC POLYESTER & COTTON (67:33) AND 100 %
POLYESTER TAPES COMPLETE WITH PACK, PACK COVER CANVAS
350 x 350 x 320 mm (CAT NO. A4/1670-000109)
(NIV)

PACK COVER ASSEMBLY

SECTION B-B
CORNER SEAM (1:1)

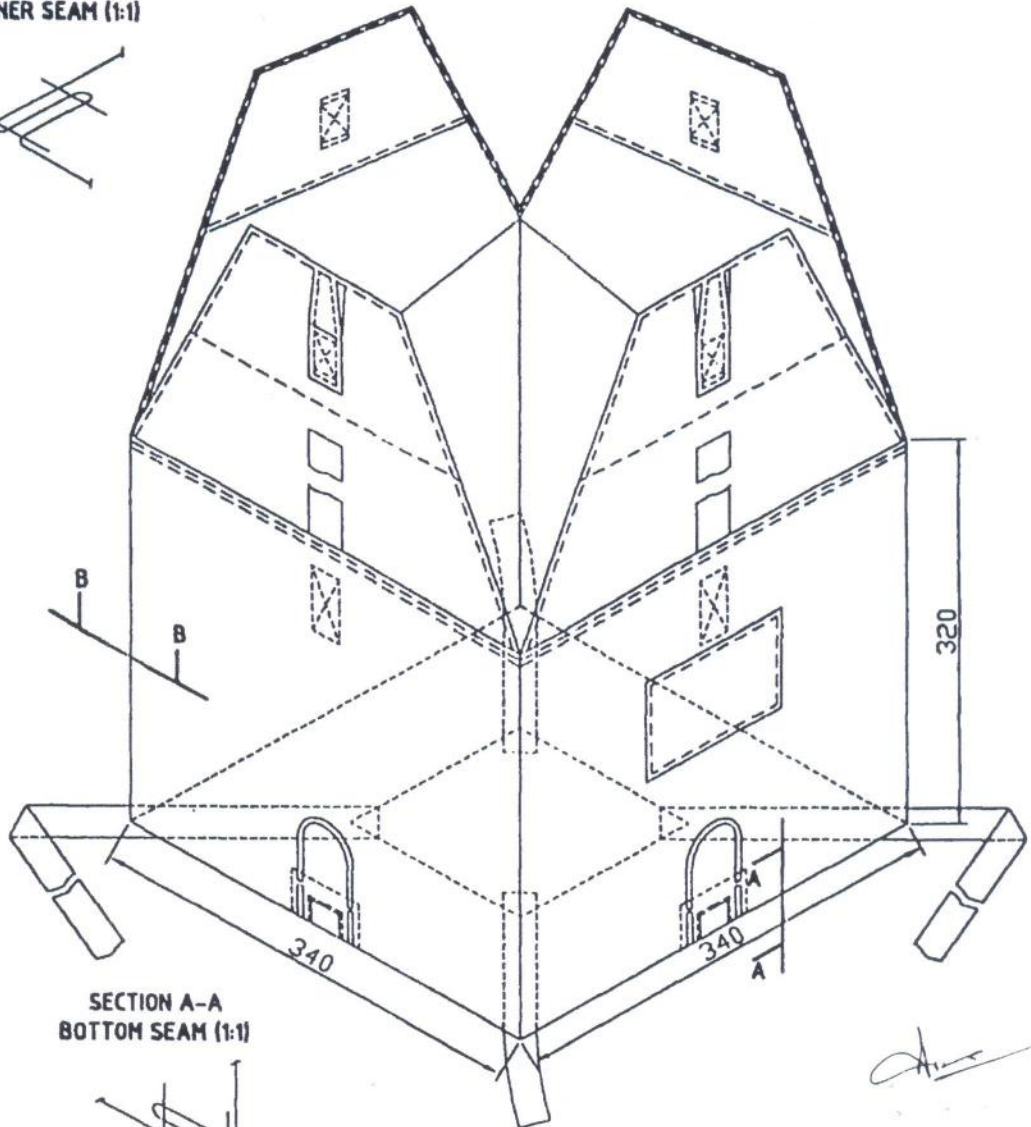

SECTION A-A
BOTTOM SEAM (1:1)

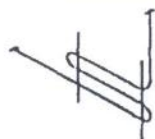

NOTE:-
ALL STITCHINGS WITH MTL 2
3-4 STITCHES PER 10 mm

ALL DIMENSIONS ARE IN mm



DGN

R. DRN
AJAY KUMAR

PSD.

APD.

DRG. ATTACHED TO SPECN. No. I 2/TC/2694

SHEET-14 OF 16

EQUIPMENT CARGO AERIAL DELIVERY PARACHUTE SUPPLY DROPPING 8.5m

MADE WITH BLENDED FABRIC POLYESTER & COTTON
(67:33) AND 100% POLYESTRE TAPES
COMPLETE WITH PACK (NIIV)
PACK COVER CANVAS 350 x 350 x 320 mm CAT NO. (A4/16710-000109)

DEVELOPMENT OF PACK

MASTER COPY

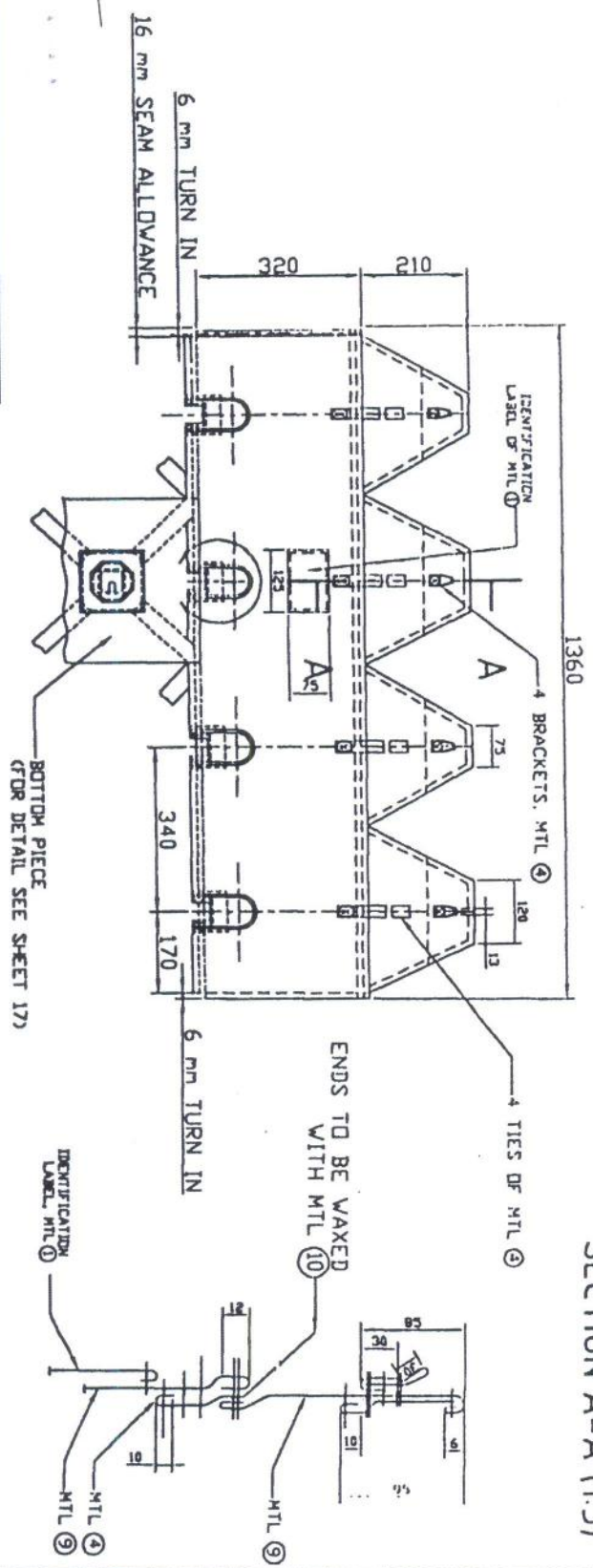

ALL DIMENSIONS ARE IN mm

	DGN	R. DRN	PSD.	APD.
		AJAY KUMAR	GO-8/10	DC-8/10
		JTO (D)		

NOTE-- (D) FOR DETAIL AT 'X', SEE SHEET 16
(DD) ALL STITCHINGS WITH MTL 2
3-4 STITCHINGS PER CM

EQUIPMENT CARGO AERIAL DELIVERY
 PARACHUTE SUPPLY DROPPING 8.5M
 MADE WITH BLENDED FABRIC POLYESTER & COTTON
 (67:33) AND 100% POLYESTRE TAPES
 COMPLETE WITH PACK (NIV)

PACK COVER CANVAS 350 x 350 x 320 mm CAT NO. (A4/1670-000109)

DETAIL AT 'X' (INSIDE VIEW)

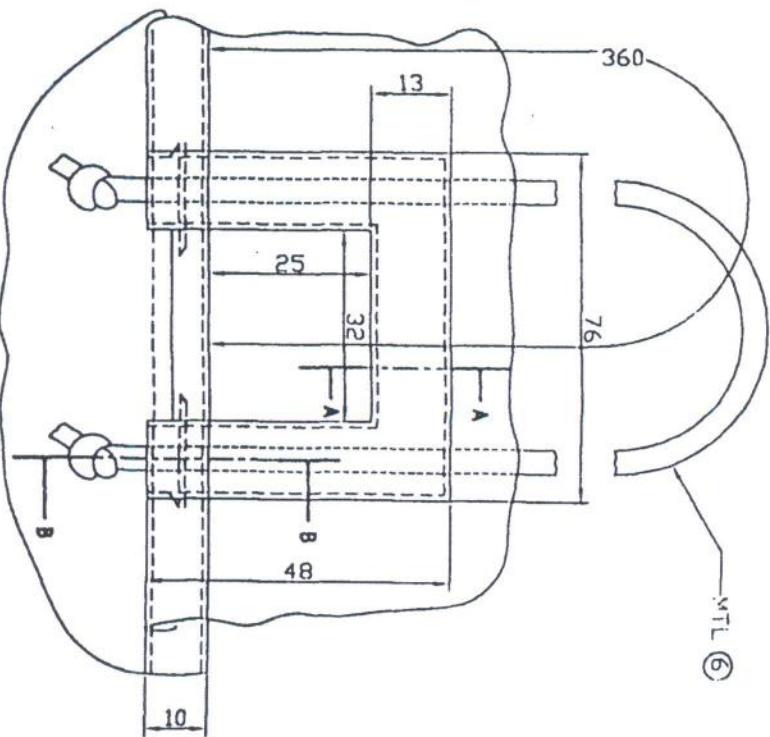

SECTION A-A

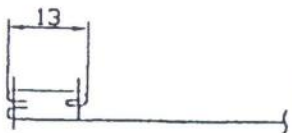

SECTION-BB

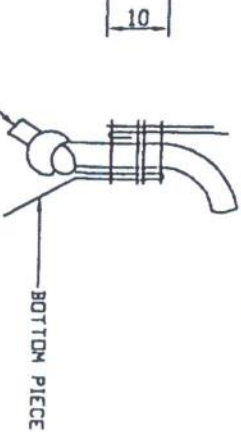

माता शर्मा
 MASTER COPY

ALL DIMENSIONS ARE IN mm



DGN

R. DRN

AJAY KUMAR
 JTO (D)

PSD

GO-8/10

APD

DC-8/10

ENDS TO BE HEAT SEALED

BOTTOM PIECE

DRG. ATTACHED TO SPECN. NO. INDT/2694

EQUIPMENT CARGO AERIAL DELIVERY PARACHUTE SUPPLY DROPPING 8.5m

MADE WITH BLENDED FABRIC POLYESTER & COTTON
(67:33) AND 100% PLYESTRE TAPES
COMPLETE WITH PACK (NIV)
PACK COVER 350 x 350 x 320 mm (CAT NO. A4/1670-000109)

BOTTOM PIECE

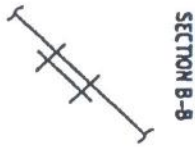
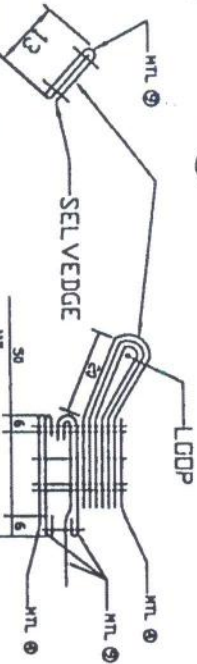
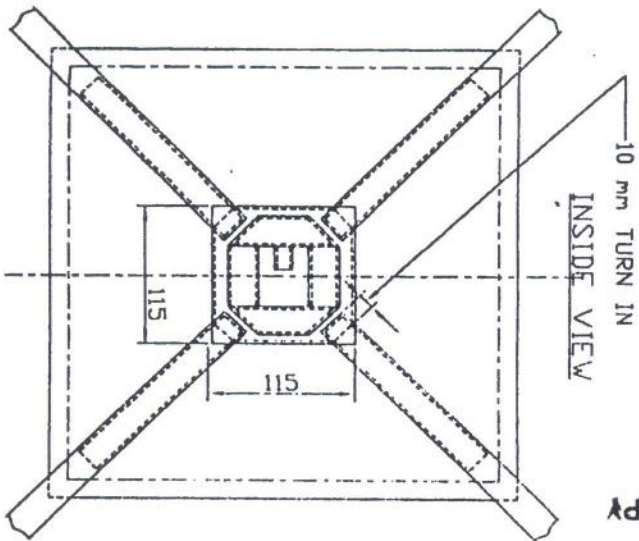
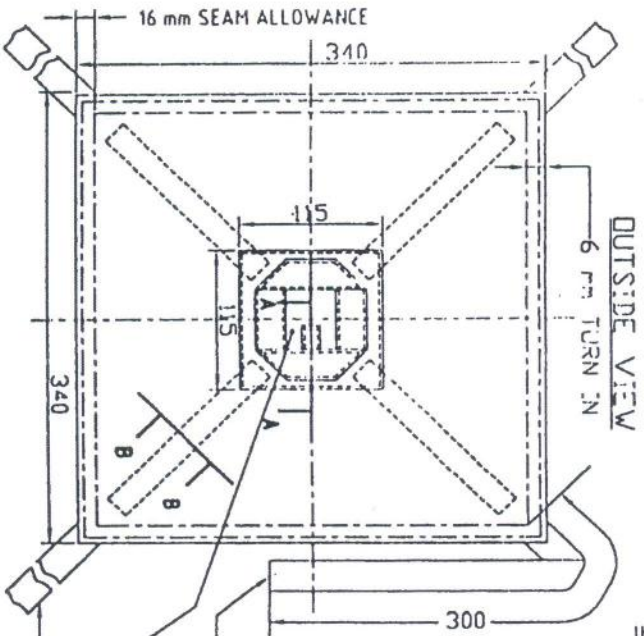

ALL DIMENSIONS ARE IN mm

	DGN	R. DRN AJAY KUMAR JTO (D)		PSD GO-8/10		APRD DC-8/10
--	-----	---------------------------------	--	----------------	--	-----------------

MASTER COPY
शुद्ध प्रत

SCALE 1:1