



Change

CHANGE SHEET No. 61		DRAWING CHANGE SHEET		AFFECTED DRG. NO. 1.3.01-06-01(a)
DATE: 30/11/2018		DRAWING TITLE: TOWING RING LARGE & SMALL BRAKE PARACHUTE (HYBRID) 17 SQM		NEW DRG. NO. 1.3.01-06-01(b)
SL. No.	SHEET NO. & LOCATION	EXISTING	AMENDED	REASON
1.	01 of 01 B5	FINISH: CADMIUM PLATED TO A MAXIMUM THICKNESS OF 0.013MM	FINISH: CADMIUM PLATED TO A MINIMUM THICKNESS OF 0.012MM	
PREPARED BY  (MANOJ KUMAR, Sc 'E') INITIATING OFFICER		APPROVED BY  (VIVEK AGRAWAL, Sc 'F') PROJECT DIRECTOR	CO — ORD. BY  04/102/19. RCMA (A/C)	
AERIAL DELIVERY RESEARCH AND DEVELOPMENT ESTABLISHMENT MINISTRY OF DEFENCE AGRA CANTT				

MATERIAL:-
STEEL WIRE TO SPECN IS:1570-1981 DESIGNATION C20

WORKMANSHIP:-
TO BE SOUNDLY WELDED AND EXTRA MATERIAL AT WELD SHALL BE REMOVED AND FINISHED SMOOTH.

FINISH:-
CADMIUM PLATED TO A MINIMUM THICKNESS OF 0.012mm AND CHROMATE PASSIVATED TO SPECIFICATION IS:1572 GRADE A, TYPE 2.

PROOF LOAD:-
490 N (50kg)

PACKING:-
ONLY ONE TYPE OF TOWING RINGS SHALL BE PACKED IN ONE CARTON /C.W.P. EACH TOWING RING SHALL BE WRAPPED IN TISSUE PAPER AND 50 Nos. AND 100 Nos. OF LARGE AND SMALL RESPECTIVELY PACKED IN SUITABLE CARTONS. 10 Nos. OF SUCH CARTONS SHALL BE PACKED IN A C.W.P. (DULY LINED WITH PAPER PACKING WATER PROOF). ONE TOWING RING IN EACH CARTON SHALL BE IDENTIFIED BY A LABEL SHOWING CAT. No. DESIGNATION OF THE STORE AND ALSO THE RECOGNISED INITIALS OF THE MANUFACTURER'S EACH CARTON SHALL BE MARKED WITH THE INITIALS OF THE MANUFACTURER.

THE PACKING CASE SHALL BE INDELIBLY MARKED WITH THE ADDRESS OF THE CONSIGNEE, CONSIGNOR, CAT No. DESIGNATION, YEAR OF THE MANUFACTURE, QUANTITY AND THE NUMBER OF THE INDIVIDUAL PACKS.

MFG. PROCESS:-
GENERAL ENGINEERING METHOD

TOLERANCES:-
± 0.4 mm IN DIMENSIONS

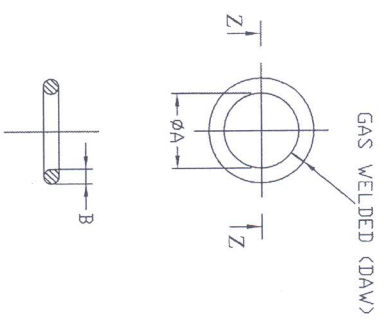

TABLE OF DIMENSION

NOMENCLATURE	INNER DIA A	WIRE THICKNESS B	No. OFF
TOWING RING SMALL	14.5	2.95	6
TOWING RING LARGE	72	4.88	1

REF. No.	DATE	ZONE	AUTHORITY	BRIEF RECORD	D I/C D&S	HEAD QA
1						

SCALE:- 1:1	ADDRD AGRA	DRN	RAVI	PRD. OFF.
DIMENSIONS IN mm	GROUP:- ABS	CHD.	NIRDT	GP. DIR.
TOL:- ± 0.4mm	TOWING RING LARGE AND SMALL DEPLOYMENT BAG BRAKE PARACHUTE (17 Sqm) HYBRID			
MATERIAL:- AS ABOVE	D/I/C D&S			
FINISH:- AS ABOVE	APPROVED			
HEAT TREATMENT:-	DRG. No.			
	1.3.01-06-01(a)			

L. M. S.
Sd/-
L. M. S.