

DIMENSIONS ARE IN mm.
 UNTOLERATED DIMNS. AS PER IS : 2102 (MED)

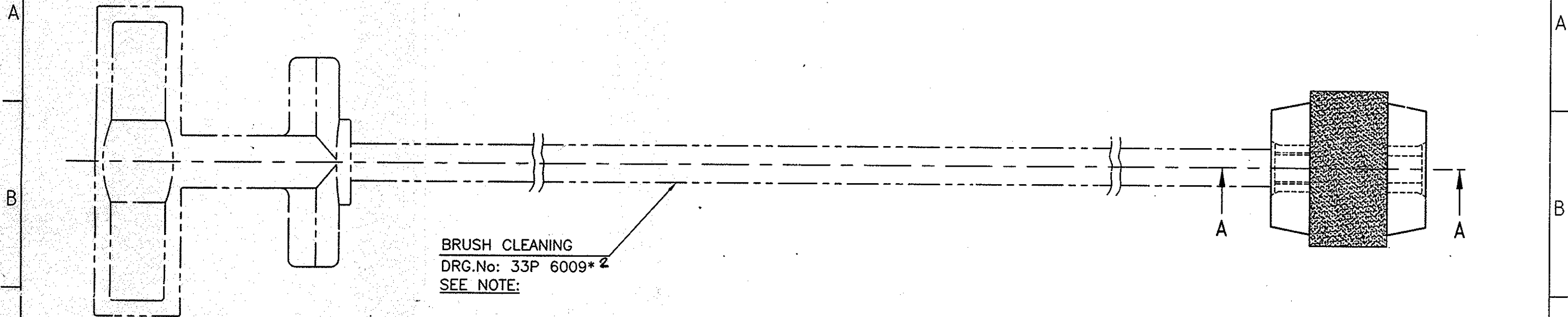

NOTE:—

1. PART No.3 SHOULD BE FLARED AT BOTH ENDS IN ORDER TO KEEP PART Nos.1&2 FIRMLY.
2. PART No.4 (BRUSH) SHOULD BE REMOVED FROM BRUSH CLEANING (33P 6009*) AND RAM ROD ASSY. WILL BE FIT TO IT FOR OILING AS SHOWN.

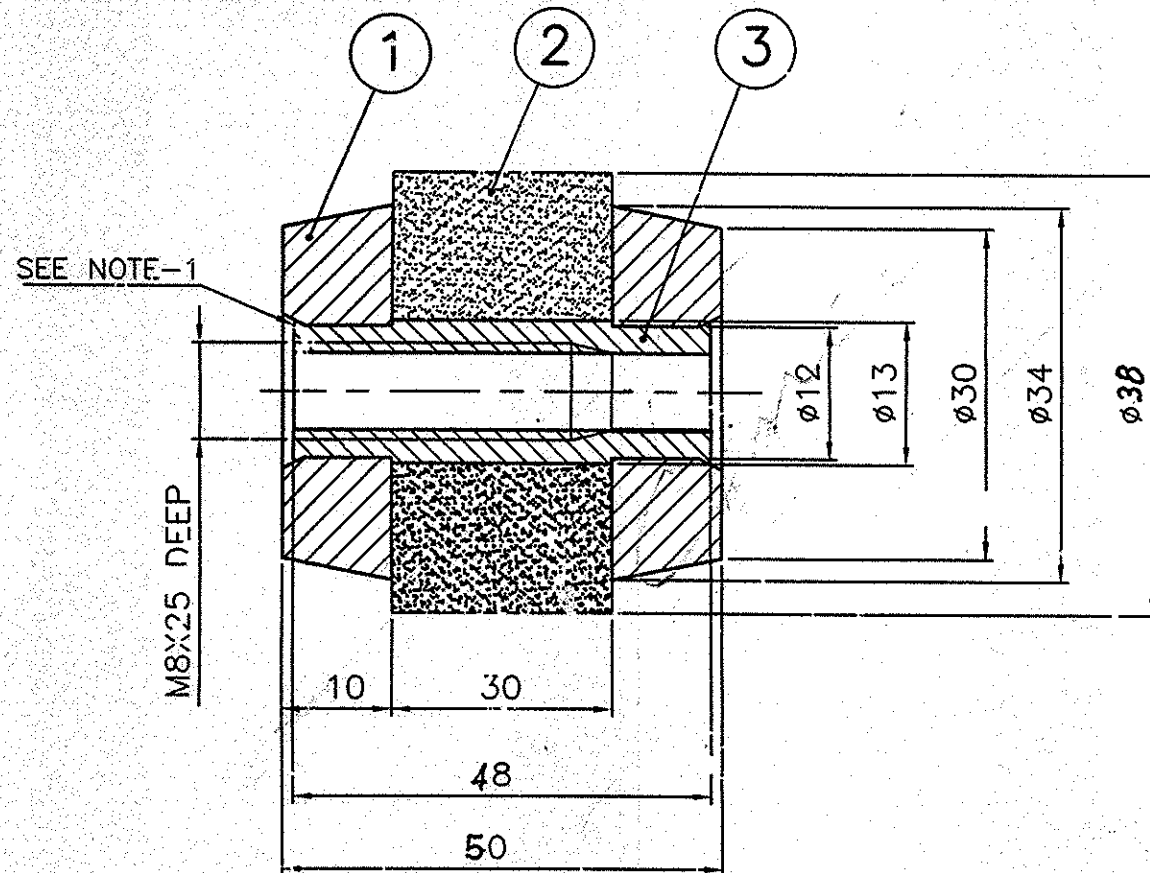

SECTION-AA

| PART NO. | DESCRIPTIONS | NO OFF | MATERIAL | TREATMENT | REMARKS |
|----------|---------------|--------|------------|-----------|---------|
| 3 | CENTER. TUBE | 1 | M.S | -- | -- |
| 2 | SPONGE GASKET | 1 | GLASS WOOL | -- | -- |
| 1 | END COVER | 2 | MOB NYLON | -- | -- |

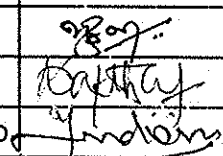
| | | | |
|--|---|---|--|
| TRACED DRAWN CHECKED C/C/D&DO OFFICER/ PRODN. OFFICER/ U&DO | SIGNATURE & DATE.  | SUB: RAM ROD ASSY FOR: OILING OF BORE & CYLINDER OF: 38mm MSL | SCALE NTS STORE DRG.NO. |
| | | DES.REF.NO. DRG. No.: 33P 6008* | OPERATION NO. SHEETS: 1 SHEET No.: 1 |
| APPROVED ON: 07/07/11 | FT ORDNANCE FACTORY TIRUCHIRAPPALLI-16. | | |