

GEN.TOL. : ±0.2  
 DRAWING CONVENTION CONFORM TO INDIAN STD.  
 DIMIN IN MM UNLESS OTHERWISE STATED

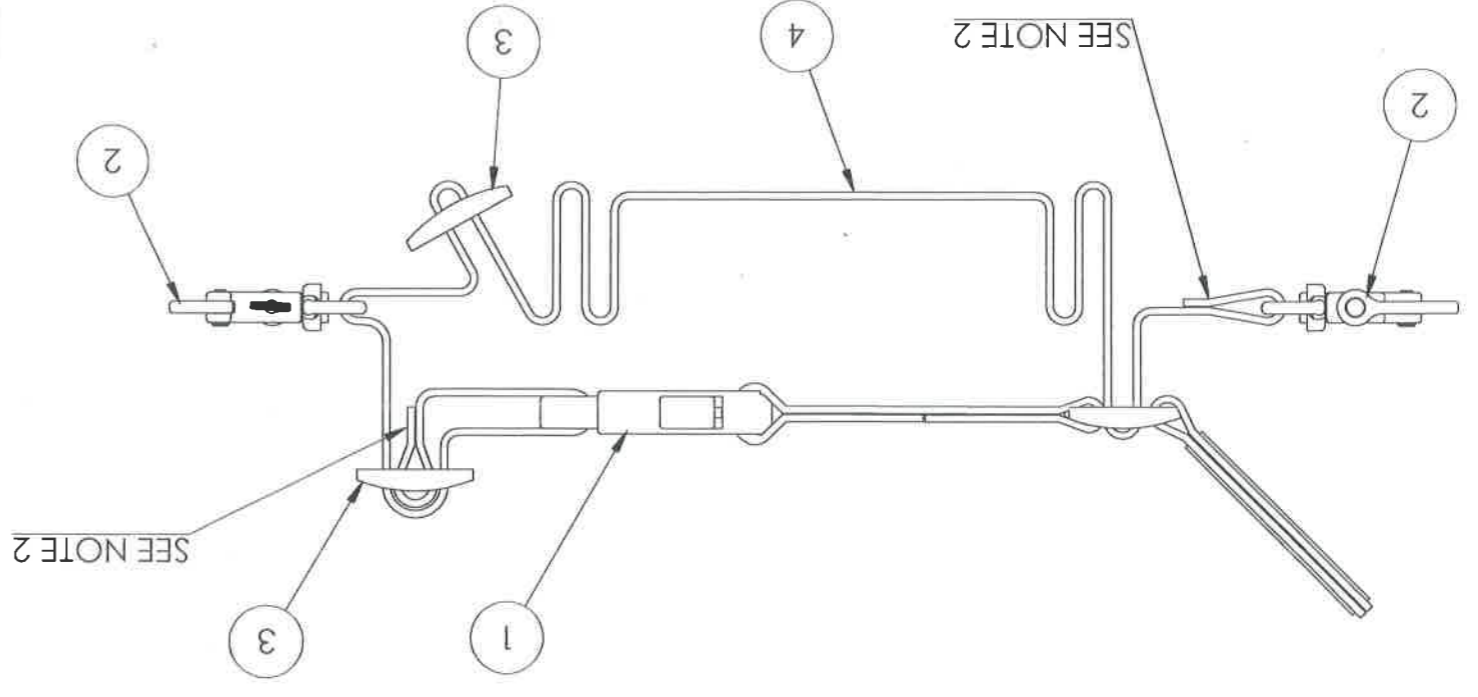

| ITEM NO. | NOMENCLATURE  | DESCRIPTION               | QTY. |
|----------|---|---------------------------|------|
| 1        | GRB AND STRAP PULLING ASSEMBLY  | 0204-04-03-00-01-000-00DA | 1    |
| 2        | HOOK SLING ASSEMBLY   | 0204-04-03-00-02-000-00DA | 2    |
| 3        | SLIDING BUCKLE  | 0204-04-03-00-00-001-00DA | 2    |
| 4        | STEEL GREY (COLOUR NO. 698 TO IS: 5-2007) NYLON WEBBING/ STRAP, LENGTH 2200.0 | IS: 4727-1968-TYPE-2      | 1    |

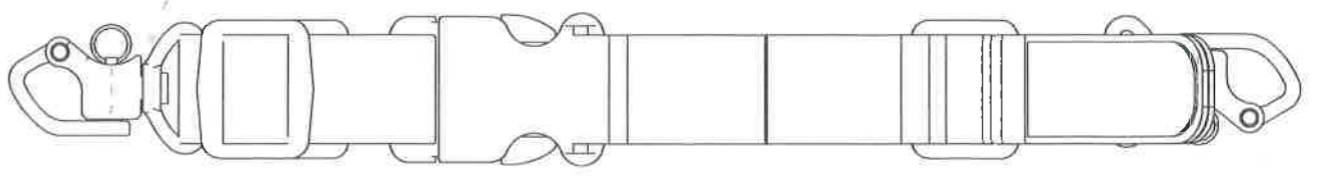
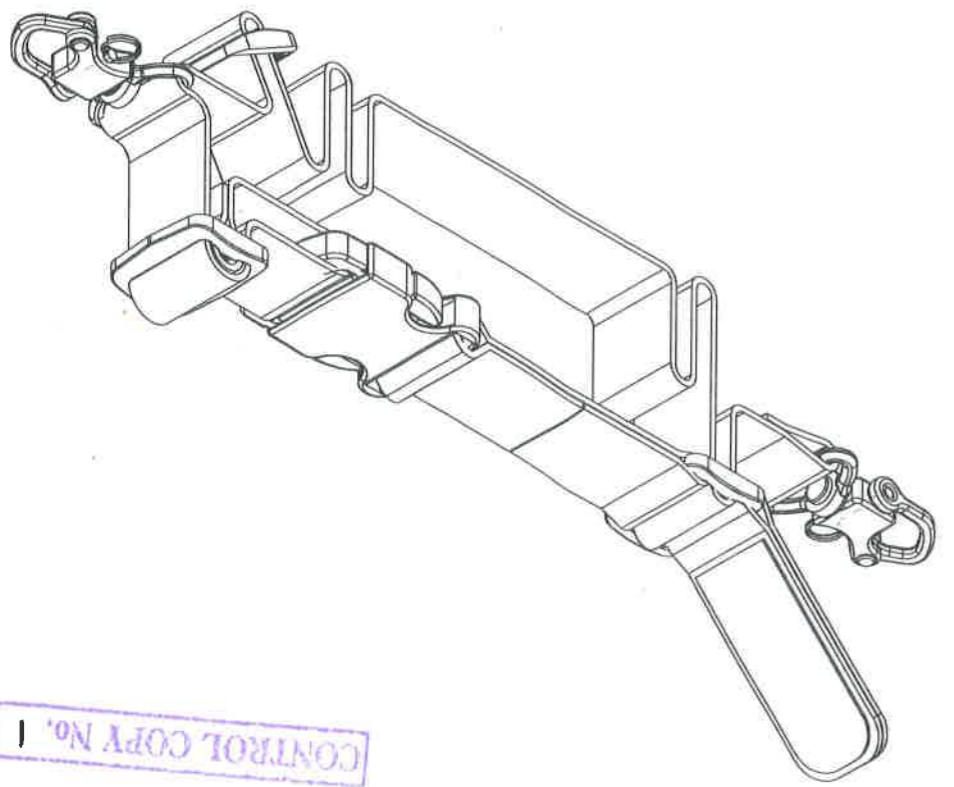

NOTE:-  
 1) BOTH THE ENDS OF WEBBING TO BE HEAT SEALED  
 2) TO BE STITCHED IN TWO ROWS WITH STEEL GREY (COLOUR NO. 698 TO IS: 5-2007) NYLON THREAD TO IS: 4229  
 3) REFER SPECIFICATION ARDE/SPECN/JVPC/2016/01(PROV) FOR DETAILS OF WEBBING

|                  |                                    |           |              |      |    |   |    |    |    |   |    |   |     |     |      |
|------------------|------------------------------------|-----------|--------------|------|----|---|----|----|----|---|----|---|-----|-----|------|
| DRG NO           | 020404                             | IC        | 04           | SS   | 04 | S | 03 | AA | 00 | A | 00 | C | 000 | SS1 | 00DA |
| PART NO          | DS CAT NO                          |           |              |      |    |   |    |    |    |   |    |   |     |     |      |
| DESIGN AUTHORITY | ARDE                               |           |              |      |    |   |    |    |    |   |    |   |     |     |      |
| SCALE            | 1:1                                |           |              |      |    |   |    |    |    |   |    |   |     |     |      |
| TITLE            | 3-POINT SLING FOR JVPC 5.56 X 30mm |           |              |      |    |   |    |    |    |   |    |   |     |     |      |
| SEALD DATE       | DATE 05/10/15 FOR DIRECTOR         |           |              |      |    |   |    |    |    |   |    |   |     |     |      |
| DRN              | SD                                 | CHD       | MATERIAL     |      |    |   |    |    |    |   |    |   |     |     |      |
| R NO             | DATE                               | AUTHORITY | BRIEF RECORD |      |    |   |    |    |    |   |    |   |     |     |      |
|                  |                                    |           | ZONE         | SIGN |    |   |    |    |    |   |    |   |     |     |      |
|                  |                                    |           | CD           | GD   |    |   |    |    |    |   |    |   |     |     |      |

CONTROL COPY No. 1