

**IS : 5088 - 1982**  
(Reaffirmed 2011)  
(Reaffirmed 2017)

*Indian Standard*  
**SPECIFICATION FOR  
COTTON TEXTILES FOR AMMUNITION**  
( *First Revision* )

UDC 677.21.064 : 623.45



© *Copyright* 1983

**INDIAN STANDARDS INSTITUTION**  
MANAK BHAVAN, 9 BHADUR SHAH ZAFAR MARG  
NEW DELHI 110002

**Gr 6**

***March 1983***

**AMENDMENT NO. 2 OCTOBER 1996**  
**TO**  
**IS 5088 : 1982 SPECIFICATION FOR COTTON**  
**TEXTILES FOR AMMUNITION**  
( *First Revision* )

( *Page 8, Table 2, Sl No. 3* ) — Under column 'Ref to IS' of 'Method of Test', substitute 'IS 1390 1983 ( *Cold Method* )' for 'IS 1390 1961'.

( *Page 8, Table 2, Sl No 8* ) — Under column 'Characteristic', substitute 'Water soluble chromate as sodium chromate, percent, *Max* ( for olive green drill )' for the existing matter.

( *Page 9, foot-note with '||' mark* ) — Substitute the following foot-note for the existing:

'||Method of determination of pH value of aqueous extracts of textile materials ( *first revision* )

( *Page 11, Appendix B* ) — Insert new clauses as under:

**"B-0. QUALITY OF REAGENTS**

**B-0.1** Unless otherwise specified, pure chemicals shall be employed in tests and distilled water [ *see IS 1070 : 1992 Reagent grade water ( third revision )* ] shall be used where the use of water as a reagent is intended.

NOTE — Pure chemicals' shall mean chemicals that do not contain impurities which affect the test results "

( TX 02 )



AMENDMENT NO. 1 MAY 1985

TO

IS : 5088 - 1982 SPECIFICATION FOR COTTON  
TEXTILES FOR AMMUNITION

*(First Revision)*

*(Page 3, clause 0.2, line 2) - Substitute  
'JSS 1-69-02(b)' for 'JSS-1-69-02(2)'.*

*[Page 5, Table 1, Sl No. (9)]:*

- a) *Col 2 - Substitute 'Drill calico' for  
'Drill'.*
- b) *Col 7 - Substitute '270' for '370'.  
Min Min*

*[Page 9, Sl No, 11(a)] - Add the word 'drill'  
after 'green'.*

(TDC 2)

Reprography Unit, ISI, New Delhi, India

IS : 5088 - 1982

***Indian Standard***  
**SPECIFICATION FOR**  
**COTTON TEXTILES FOR AMMUNITION**  
**( *First Revision* )**

---

Cotton and Cotton Products sectional Committee, TDC 2

<i>Chairman</i>	<i>Representing</i>
SHRI A. SUBRAMANIAM	Madura Coats Limited, Madurai
<i>Members</i>	
SHRI A. CHELLARAJ ( <i>Alternate to</i> Shri A. Subramaniam )	
DR N. BALASUBRAMANIAM	The Bombay Textile Research Association, Bombay
SHRI M. K. BARDHAN	Ministry of Defence ( DGI )
SHRI R. K. MEHRA ( <i>Alternate</i> )	
SHRI A. T. BASAK	Inspection Wing, Directorate General of Supplies & Disposals, New Delhi
DR H. P. BHATTACHARYA	National Textile Corporation Ltd, New Delhi
SHRI P. P. CHECKER ( <i>Alternate</i> )	
SHRI G. N. CHATTERJI	Ministry of Defence ( R & D )
SHRI R. GHOSH ( <i>Alternate</i> )	
DIRECTOR OF HANDLOOMS & TEXTILES	Government of Tamil Nadu
THE SPECIAL OFFICER TAMIL NADU HANDLOOM WEAVERS CO-OP SOCIETY LTD, MADRAS ( <i>Alternate</i> )	
SHRI A. GHOSH	National Test House, Calcutta
SHRI K. K. GOEL	Textiles Committee, Bombay
SHRI R. V. NANDREKAR ( <i>Alternate</i> )	
SHRI R. N. JOSHI	The Millowners' Association, Bombay
SHRI R. M. MERCHANT	The Cotton Textiles Export Promotion Council, Bombay
SHRI C. A. CRASTO ( <i>Alternate</i> )	
PROF D. V. MUNISWAMY	Government of Karnataka
SHRI GAUTAMBHAI S. NANAVATY	The Ahmedabad Textile Mills' Association, Ahmadabad
DR P. R. ROY ( <i>Alternate</i> )	

( *Continued on page 2* )© *Copyright* 1983

INDIAN STANDARDS INSTITUTION

This publication is protected under the *Indian Copyright Act* ( XIV of 1957 ) and reproduction in whole or in part by any means except with written permission of the publisher shall be deemed to be an infringement of copyright under the said Act.

**IS : 5088 - 1982***( Continued from page 1 )*

<i>Members</i>	<i>Representing</i>
SHRI C. K. PHADKE	Office of the Textile Commissioner, Bombay
SHRI S. P. GHOSAL ( <i>Alternate</i> )	
SHRI T. RANGASWAMY	The Southern India Millowners' Association, Coimbatore
SHRI T. V. RATNAM	South India Textile Research Association, Coimbatore
SHRI UTTAM SINGH SACHDEVA	The Delhi Cloth & General Mills Co Ltd, Delhi
SHRI N. S. SHARMA	The All India Federation of Co-operative Spinning Mills Ltd, Bombay
SHRI M. G. SODHANI	Keshavlal Talakchand ( Pvt ) Ltd, Bombay
SHRI BASUDEV SOMANI	The East India Cotton Association Ltd, Bombay
SHRI CHANDRASINH HANSRAJ	
MIRANI ( <i>Alternate</i> )	
CDR J. M. S. SOOD	Naval Headquarters, New Delhi
SHRI T. R. IYENGAR ( <i>Alternate</i> )	
SHRI N. R. SUBBARAMAN	Calico Mills, Ahmadabad
SHRI V. N. SUBBA RAO	Binny Limited, Madras
DR V. SUNDARAM	Indian Council of Agricultural Research, New Delhi
DR V. G. MUNSHI ( <i>Alternate</i> )	
SHRI S. M. CHAKRABORTY, Director ( Tex )	Director General, ISI ( <i>Ex-officio Member</i> )

*Secretary*

SHRI G. S. ABHYANKAR  
Deputy Director ( Tex ), ISI

**Cotton and Cotton Products Subcommittee, TDC 2 : 1***Convener*

SHRI UTTAM SINGH SACHDEVA The Delhi Cloth & General Mills Co Ltd, Delhi

*Members*

SHRI P. LAL ( <i>Alternate</i> to Shri Uttam Singh Sachdeva )	
SHRI A. T. BASAK	Inspection Wing, Directorate General of Supplies & Disposals, New Delhi
SHRI D. K. NANDY ( <i>Alternate</i> )	
SHRI R. DHARMARAJAN	Modi Spinning & Weaving Mills Co Ltd, Modinagar
SHRI R. N. JOSHI	The Bombay Millowners' Association, Bombay
PROF R. C. D. KAUSHIK	The Technological Institute of Textiles, Bhiwani
SHRI GAUTAMBHAI S. NANAVATI	The Ahmedabad Textile Mills' Association, Ahmadabad
SHRI K. R. SITWALA ( <i>Alternate</i> )	
SHRI C. K. PATEL	Calico Mills, Ahmadabad
SHRI C. K. PHADKE	Office of the Textile Commissioner, Bombay
SHRI S. P. GHOSAL ( <i>Alternate</i> )	

*( Continued on page 20 )*

IS : 5088 - 1982

*Indian Standard*  
SPECIFICATION FOR  
COTTON TEXTILES FOR AMMUNITION  
( *First Revision* )

**0. FOREWORD**

**0.1** This Indian Standard ( First Revision ) was adopted by the Indian Standards Institution on 15 May 1982, after the draft finalized by the Cotton and Cotton Products Sectional Committee had been approved by the Textile Division Council.

**0.2** This standard was originally published in 1969. This revision has been necessitated to align it with the requirements of JSS-1-69-02(2) and JSS 1266 issued by the Ministry of Defence, Government of India.

**0.3** This opportunity has also been availed to amalgamate Part I — Fabrics used in the manufacture of propellant charges and other purposes ( based on JSS 1258 ); and Part II — Cotton drill olive green proofed used in the manufacture of Bandoliers ( Based on JSS 1268 ).

**0.4** Standards of Weights and Measures Act, 1976 stipulates the use of International System of Units in the country; in order to familiarize the industry with this system, the recommended SI units for use in the textile industry are given in Appendix C.

**0.5** For the purpose of deciding whether a particular requirement of this standard is complied with, the final value, observed or calculated, expressing the result of a test, shall be rounded off in accordance with IS : 2-1960\*. The number of significant places retained in the rounded off value should be the same as that of the specified value in this standard.

---

**1. SCOPE**

**1.1** This standard prescribes the constructional details and other requirements of nine varieties of cotton fabrics used in ammunition. The end use of these fabrics is given in Appendix A.

---

\*Rules for rounding off numerical values ( *revised* ).

## IS : 5088 - 1982

**1.2** This standard does not specify the general appearance, feel, shade, etc, of the cloth ( *see also* 3.3 )

## 2. MANUFACTURE

**2.1 Yarn** — The cotton yarn used in the manufacture of the cloth shall be satisfactory in evenness and reasonably free from neps and other spinning defects.

**2.2 Cloth** — The cloth shall be free from dressing and filling materials and substances liable to increase mass or cause subsequent tendering.

**2.2.1** The olive green drill shall be thoroughly shrunk.

**2.2.2** The cloth shall be dyed with suitable dyes to shades as agreed to between the buyer and the sellers ( *see* Note ). In case of olive green shade the cloth shall be dyed with vat dyes in conjunction with iron and chromium salts ( mineral khaki ).

NOTE — Sulphur dyes shall not be used for dyeing the cloth.

**2.2.3** The bleached cloth shall have a full bleached finish and shall be free from blueing or optical whitening agents.

**2.2.4** The selvages shall be firm and straight. In case of olive green drill, the selvages shall be woven either with reverse draft or with plain ends of a maximum of 6 mm width to prevent curling.

**2.2.5** The dyed cloth shall not develop acidity on ageing or liable to tendering. The cloth when kept in contact with non-ferrous metals, shall not promote corrosion.

**2.2.6** The cloth when visually examined shall be reasonably free from spinning, weaving and processing defects.

**2.2.7** The dye used for dyeing shall be compatible to explosives.

## 3. REQUIREMENTS

**3.1** The constructional particulars of the cloth shall conform to those given in Table 1 excepting the count of warp and weft yarn which have been given for guidance only.

NOTE — For testing the conformity of various requirements given in Tables 1 and 2, the test specimen shall be conditioned in standard atmosphere of  $65 \pm 2$  percent relative humidity and  $27 \pm 2^\circ\text{C}$  temperature ( *see* IS : 6359-1971\* ) and tested in the standard atmosphere.

---

\*Method for conditioning of textiles.

**TABLE 1 CONSTRUCTIONAL PARTICULARS OF COTTON FABRICS FOR AMMUNITION**  
( Clause 3.1 )

VARIETY No	TYPE	APPROXIMATE COUNT OF YARN COTTON COUNT ( TEX )		ENDS/ cm Min	PICKS/ Cm Min	MASS (7) g/m <sup>2</sup> Min	BREAKING LOAD ON 50 × 20 cm STRIPS ( REVELLED STRIPS METHOD ), Min		LENGTH WIDTH Mm	WEAVE	
		Warp	Weft				W <sub>ft</sub> (8) N ( kgf )	W <sub>ft</sub> (9) N ( kgf )			
(1)	(2)	(3)	(4)	(5)	(6)	(7)	W <sub>ft</sub> (8) N ( kgf )	W <sub>ft</sub> (9) N ( kgf )	(10) m	(11) cm	(12)
1.	Drill (Olive green dyed)	14s (42 tex)	12s (50 tex)	38	19	260 Min	1 075 (110)	625 (64)	20	91	3/1 warp-faced twill
	Cambric ( Bleached or dyed )	60s ( 10 tex )	60s ( 10 tex )	40	32	60 to 75	215 (22)	145 (15)	20	91	Plain
3.	Calico ( Bleached )	—	—	30	30	145 Min	300	300	20	91	Plain
4.	Calico ( Bleached )	36s ( 16.5 tex )	36s ( 16.5 tex )	40	39	135 Min	430(44)	400(41)	20	91.5	Plain
5.	Calico	—	—	36	30	67 to 72	300(31)	180 19)	20	91	Plain
6	Drill	—	—	39	13	290 Min	860(88)	800 82)	20	91	3/1 warp-faced twill
7.	Calico ( Bleached )	—	—	27	27	160 to 180	380(39)	290 (30)	20	91	Plain
8.	Cambric	—	—	23	20	35 to 45	130 14)	65(6)	20	91	Plain
9.	Drill	50 tex	60 tex	35	20	370 Min	590(61)	590(61)	20	91	3/1 warp-faced twill
Tolerance percent	—	—	—	—	—	+ 5 — 2.5	—	—	—	—	± 2
Method of test	—	—	—	IS : 1963-1969*	IS : 1964-1970†	IS : 1969-1968‡	IS : 1954-1969§	IS : 1954-1969§	IS : 1954-1969§	Visual	Visual

NOTE 1 — 1 Newton (N) is approximately equal to 0.102 kgf.

NOTE 2 — The thickness of cloth for variety No 8 shall be between 0.09 mm and 0.10 mm and measured by following the method given in IS : 7702-1975].

\*Methods for determination of threads per decimetre in woven fabrics ( first revision ).

†Methods for determination of weight per square metre and weight per linear metre of fabrics ( first revision ).

‡Method for determination of breaking load and elongation at break of woven textile fabrics ( first revision ).

§Methods for determination of length and width of fabrics ( first revision ).

||Method for determination of thickness of woven and knitted fabrics

IS : 5088 - 1982



## IS : 5086 - 1982

**3.2** The colour fastness ratings and other requirements of the cloth shall conform to those given in Table 2.

NOTE 1 — Fabrics for covers and other fabrics for rubber proofing shall be free from copper, manganese and their compounds when tested as per **B-6**.

NOTE 2 — If the cloth variety No. 6 is supplied in the loom state, the requirements given in Table 2 are not applicable.

NOTE 3 — See Note under **3.1**.

**3.3 Sealed Sample** — If in order to illustrate indeterminable characteristics, such as, general appearance, lustre, feel and shade of the cloth, a sample has been agreed upon and sealed, the supply shall be in conformity with the sample in such respects.

**3.3.1** The custody of the sealed sample shall be a matter of prior agreement between the buyer and the seller.

## 4. MARKING

**4.1** The cloth shall be marked with the following:

- a) Name of the material;
- b) Length and width of the piece;
- c) Manufacturer's name, initials, or trade-mark, if any; and
- d) Year of manufacture.

**4.1.1** The cloth may also be marked with the ISI Certification Mark.

NOTE — The use of the ISI Certification Mark is governed by the provisions of the Indian Standards Institution ( Certification Marks ) Act and the Rules and Regulations made thereunder. The ISI Mark on products covered by an Indian Standard conveys the assurance that they have been produced to comply with the requirements of that standard under a well-defined system of inspection, testing and quality control which is devised and supervised by ISI and operated by the producer. ISI marked products are also continuously checked by ISI for conformity to that standard as a further safeguard. Details of conditions under which a licence for the use of the ISI Certification Mark may be granted to manufacturers or processors, may be obtained from the Indian Standards Institution.

**4.2** At the other end of the piece, the cloth shall be marked with an identification mark.

## 5. PACKING

**5.1** The cloth shall be packed in bales or cases in conformity with the procedure laid down in IS : 1347-1972\* or in IS : 293-1980† as required.

---

\*Specification for inland packaging of cotton cloth and yarn (*first revision* ).

†Specification for seaworthy packaging of cotton yarn and cloth ( *third revision* ).

## IS : 5088 - 1982

TABLE 2 REQUIREMENTS OF COTTON FABRICS FOR AMMUNITION

( Clause 3.2 )

SL No.	CHARACTERISTIC	REQUIREMENT	METHOD OF TEST	
			Ref to IS	Clause No. in Appendix
1.	Colour fastness to			
	a) Light	5 or better	IS : 2454-1967*	—
	b) Washing: Test 2	4 or better	IS : 3361-1965†	—
	c) Nitrogen oxides ( for variety No. 8 only )	5 or better	IS : 1690-1960‡	—
2.	Scouring loss, percent, <i>Max</i>	2.0	IS : 1383-1977§	—
3.	pH value		IS : 1390-1961	—
	a) Olive green drill	5.5 to 9.5		
	b) Other fabrics	5.5 to 8.5		
4.	Shrinkage or elongation, percent, <i>Max</i>		IS : 2977-1964¶	—
	a) Olive green drill	2.0		—
	b) Other fabrics	4.0		—
5.	Water soluble chlorides as sodium chloride, percent, <i>Max</i>		—	B-1
	a) Olive green drill	0.1		
	b) Other fabrics	0.05		
6.	Water soluble sulphates as sodium sulphate, percent, <i>Max</i>		—	B-2
	a) Olive green drill	0.50		
	b) Other fabrics	0.25		
7.	Sulphur and sulphur compounds as sulphur (for other fabrics), percent, <i>Max</i>	0.01	—	B-3
8.	Water soluble chromates, percent, <i>Max</i> (for olive green drill )	0.1	IS : 5449-1969**	—
9.	Soda soluble chromium compounds, as sodium chromate ( $\text{Na}_2\text{CrO}_4$ ), percent, <i>Min</i> ( for olive green drill )	0.07	—	B-4
10.	Iron and chromium compounds, as $\text{Fe}_2\text{O}_3$ and $\text{Cr}_2\text{O}_3$ , percent, <i>Min</i> for olive green drill	1.5	IS : 4655-1968††	—

( Continued )

## IS : 5088 - 1982

TABLE 2 REQUIREMENTS OF COTTON FABRICS FOR AMMUNITION — *Contd*

SL No.	CHARACTERISTIC	REQUIREMENT	METHOD OF TEST	
			Ref to IS	Clause No. in Appendix
11.	Ash content, percent, <i>Max</i>		IS : 199-1973††	—
	a) Other fabrics except olive green	0.5		
	b) For variety No. 5	1.0		
12.	Moisture regain, percent, <i>Max</i>	9.0	IS : 199-1973‡‡	—
13.	Lead and compounds of lead calculated as metallic lead, percent, <i>Max</i> ( when required as free from lead by agreement )	0.03	—	B-5
14.	Matter extractable by ether, percent, <i>Max</i> for variety No. 9	0.5	IS : 4390-1967§§	—
15.	Fatty acid or similar acids extractable by ether, as oleic acid, percent, <i>Max</i> for variety No. 9	0.25	IS : 4390-1967§§	—
16.	Water extractable matter, percent, <i>Max</i>	per- 1.0	IS : 3456-1906	—

NOTE — The requirements at SI No. 2, 5 and 15 are calculated on dry mass of the materials.

\*Method for determination of colour fastness of textile materials to artificial light ( xenon lamp ).

†Method for determination of colour fastness of textile materials to ashing: Test 2.

‡Method for determination of colour fastness of textile materials to nitrogen oxides.

§Methods for determination of scouring loss in grey and finished cotton textile materials (*first revision*).

||Methods for determination of pH value of aqueous extracts of textile materials.

¶Method for determination of dimensional changes of woven fabrics ( other than wool ) on soaking in water.

\*\*Methods for determination of water soluble chromate in textile materials.

††Methods for determination of iron and chromium in textiles.

‡‡Methods for estimation of moisture, total size or finish, ash and fatty matter in grey and finished cotton textile materials (*second revision*).

§§Method for determination of ether-soluble matter in textile materials.

||| Method for determination of water soluble matter in textile materials.

**IS : 5088 - 1982**

## **6. SAMPLING**

**6.1** The scale of sampling and criteria for conformity as given in IS : 3919-1966\* shall be followed in respect of physical characteristics, namely, ends and picks, mass, breaking load, length and width of cloth.

**6.2** The scale of sampling and criteria for conformity as given in IS : 5463-1969† shall be followed in respect of the chemical characteristics, namely, colour fastness, scouring loss, pH value, shrinkage or elongation, water, etc.

## **APPENDIX A**

( *Clause 1.1* )

### **END USE OF COTTON FABRICS FOR AMMUNITION**

<i>Variety No.</i>	<i>End Use</i>
1	Bandoliers
2	Bags for propellant cordite charges
3	Propellant bags and miscellaneous uses
4	Straining purposes for the manufacture of mercury fulminate and lead azide
5	For tail and muzzle covers
6	For B. L. & Q. F. drill cortridge
7	For TNT bags
8	—
9	For light TNT and CE bags.

---

\*Methods for sampling cotton fabrics for determination of physical characteristics.

†Methods for sampling of cotton fabrics for chemical tests.

IS : 5088 - 1982

## APPENDIX B

( Table 2 )

### METHODS OF TESTS

#### B-1. DETERMINATION OF WATER SOLUBLE CHLORIDES

##### B-1.1 Procedure

**B-1.1.1** Take about 12.5 g of sample and weigh accurately. Cut the sample into small pieces of approximately 1 cm<sup>3</sup> pieces. Reflux the sample with 200 ml of distilled water for 30 minutes. Decant the liquor and extract the test sample twice with two further volumes of 100 ml of distilled water for 15 minutes. Combine the extracts and filter, if necessary. Cool the extracts to room temperature and make up the volume to 500 ml with distilled water.

**B-1.1.2** Dilute 10 ml of the aqueous extract, prepared as described in **B-1.1.1** up to 60 ml with distilled water and add 1 ml of 5 percent nitric acid. Stir and filter through a Whatman No. 40 paper into 100-ml Nessler tube, washing twice with distilled water and add 1 ml of 0.1 percent aqueous solution of silver nitrate. Stir thoroughly and compare the turbidity with a series of standards prepared at the same time under similar conditions.

**B-1.1.3** If appreciable precipitate is observed then estimate the water soluble chlorides by the volumetric method as given below.

##### **B-1.1.4** *Volumetric Method*

Add 5 ml of concentrated nitric acid to a portion ( 200 ml equivalent to 5 g sample ) of the aqueous extract. Filter, if necessary. Add a known amount of silver nitrate solution ( 5 or 10 ml of N/20 silver nitrate ) to precipitate soluble chloride as silver chloride. Titrate the excess of silver nitrate against standard ammonium/potassium thiocyanate solution using 5 ml of 10 percent ferric alum solution as indicator.

**B-1.1.5** Carry out a blank on the water used for extraction using the same amount of reagents. Calculate the percentage of soluble chloride as sodium chloride.

**IS : 5088 - 1982**

## **B-2. DETERMINATION OF WATER SOLUBLE SULPHATES**

### **B-2.1 Procedure**

**B-2.1.1** Prepare an aqueous extract of 10 g of the sample, as given in **B-1.1.1**. Filter, make up the volume to 400 ml with distilled water and add 3 ml of concentrated hydrochloric acid. Boil and add 10 ml boiling 10 percent solution of barium chloride drop by drop. Continue boiling until the preprecipitate coagulates ( 1 hour ). Allow to cool over night, filter through No. 42 Whatman filter paper, wash until the filtrate is free from chloride, dry and weigh the barium sulphate after incineration in the usual way. Carry out blank test under similar conditions, with the reagents used and apply correction if necessary.

## **B-3. DETERMINATION OF SULPHUR AND SULPHUR COMPOUNDS**

**B-3.1 Principle** — The dyed fabric is treated with zinc and hydrochloric acid and the stain produced on lead acetate paper by the hydrogen sulphide liberated from the day is compared with that produced by known quantities of sodium sulphide under identical conditions of test.

### **B-3.2 Reagents**

#### **B-3.2.1** *Standard Sodium Sulphide Solution*

**B-3.2.1.1** Dissolve 0.244 g of sodium sulphide of the analytical reagent grade in distilled water in a 1 000-ml standard flask and make up to the mark. One ml of this solution is equivalent to 0.1 mg of sulphur.

#### **B-3.2.2** *Lead Acetate Papers*

**B-3.2.2.1** Prepare 100 ml of a 5 percent *w/v* aqueous solution of normal lead acetate in a 250-ml beaker. Soak a few circles of a No. 1 Whatman filter paper all at a time, drain and allow to dry at 100°C in an atmosphere free from hydrogen sulphide. Cut into rectangular strips 25 × 5 mm each and keep them closed inside a clean dry glass-stoppered bottle.

#### **B-3.2.3** *Hydrochloric Acid*

**B-3.2.3.1** Prepare 500 ml of 1 : 2 (*v/v*) hydrochloric acid, by diluting Analytical Reagent Grade HCl with twice its volume of water.

#### **B-3.2.4** *Zinc Analytical Reagent Grade in the Form of Granules*

### **B-3.3 Apparatus**

**B-3.1.1** The set up of the apparatus for carrying out the test is as given in Fig. 1.

IS : 5088 - 1982

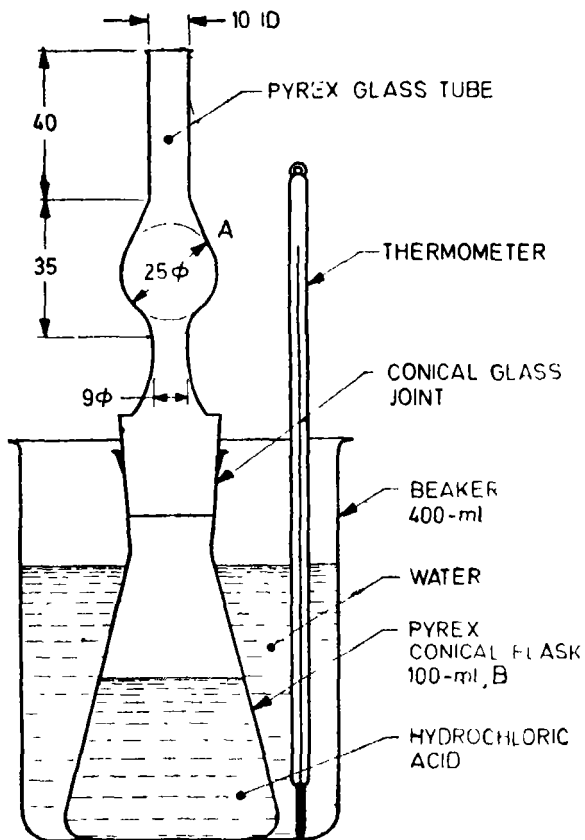

All dimensions in millimetres.

FIG. 1 APPARATUS FOR DETERMINATION OF SULPHUR

**B-3.4 Procedure**

**B-3.4.1** Transfer 5 g of the shredded and finely chopped material into the conical flask 'B'. Add 50 ml of the hydrochloric acid and allow it to wet the material thoroughly.

**B-3.4.2** Plug the tube 'A' with clean glass wool at the bottom of the bulb, place a strip of the lead acetate paper and plug the top of the bulb with glass wool.

**IS : 5088 - 1982**

**B-3.4.3** Keep the flask inside the beaker containing water, such that the water level comes nearly up to the neck. Adjust the temperature of water to  $27 \pm 2^\circ\text{C}$  with the help of the thermometer adding cold water or warm water as necessary, clamping the flask if it tends to be buoyed up.

**B-3.4.4** Add 2.5 g of zinc and quickly fit the flask with the tube. Swirl the flask to ensure good mixing of the contents and adjust the temperature of the water as described in **B-3.4.3**.

**B-3.4.5** After the initial vigorous effervescence has subsided, keep the flask for 1 hour inside the beaker with the water maintained at  $27 \pm 2^\circ\text{C}$ .

**B-3.4.6** At the end of period remove the paper strip and keep it inside a ground glass-stoppered moisture dish or test-tube or bottle.

**B-3.4.7** Carry out a blank using the reagents and procedures described in **B-3.4.1** to **B-3.4.6** except for the use of the material. If the lead acetate paper shows a perceptible stain repeat the blank with a different zinc sample or hydrochloric acid or water as the case may be and use only those reagents that give no perceptible stain.

**B-3.4.8** Prepare standard stains using 1 ml, 2 ml, 3 ml, 4 ml, 5 ml, respectively of the standard sodium sulphide solution adopting the procedure described in **B-3.4.1** to **B-3.4.6** except for the use of the material.

**B-3.4.9** Compare the stain produced by the sample with those produced by the standard.

**B-3.4.10** The material shall be taken as complying with the requirement if the stain produced by the sample is not darker than that produced by 5 ml of the standard sodium sulphide.

**B-4. DETERMINATION OF SODA SOLUBLE CHROMIUM COMPOUND****B-4.1 Procedure**

**B-4.1.1** Treat the sample remaining after water extraction, with 100 ml of sodium hydroxide solution at  $49^\circ\text{C}$  and stir frequently. Filter the alkaline extract through a No. 54 Whatman filter paper. Wash the fabric thoroughly with hot water and squeeze well. Boil the extract and add dropwise a saturated solution of potassium permanganate until the green colour is permanent for 1 minute. Cool the solution to approximately  $60^\circ\text{C}$ , acidify with dilute sulphuric acid and allow to stand on the steam bath until the faint permanganate colour has disappeared. Filter the solution through No. 42 Whatman filter paper, wash the precipitate until free from chromium compounds and cool. Add 10 ml of N/20 ferrous ammonium sulphate solution followed by 10 ml of mixed acid solution and titrate with N/20 potassium dichromate solution.



IS : 5088 - 1982

**B-4.2 CALCULATION**

**B-4.2.1** Calculate the percentage of soda soluble compound by the following formula:

$$S = \frac{(B - E) \times 0.27}{W}$$

where

$S$  = soluble chromium as  $\text{Na}_2 \text{CrO}_4$ ;

$B$  = volume in ml, of N/20 potassium dichromate solution required for the blank;

$E$  = volume in ml, of N/20 potassium dichromate solution required for sample; and

$W$  = mass, in g, of the sample taken.

**B-5. DETERMINATION OF LEAD AND LEAD COMPOUNDS**

**B-5.1 Procedure** — Weigh 10 g of the material in a silica basin, and ash it carefully until only slight traces of carbon remain. The temperature of the basin shall not be allowed to rise above faint red hot as at higher temperature some lead may be lost by volatilization. Treat the ash so obtained with dilute nitric acid. The quantity of acid is immaterial provided it is sufficient to extract the soluble matter, but avoid too great an excess since it has to be evaporated off. Allow the basin to stand on a boiling water-bath for at least three hours. In case a large quantity of insoluble residue is felt, heat the basin on the water-bath over-night. Decant off the supernatant liquid through a filter paper and extract the insoluble residue again on a boiling water-bath for one hour with dilute nitric acid. Filter through the same filter paper and wash the residue thoroughly on the filter paper with hot water. Treat the residue on the filter paper with 10 ml of ammonium acetate solution, filter and wash again. Mix the filtrate and washings in a 500 ml evaporating basin, and 2 ml of concentrated sulphuric acid and evaporate the contents of the basin on a sand-bath till fumes appear. Add 100 ml of water to the basin and allow to stand on the boiling water-bath for 15 minutes. Then dilute the contents to about 150 ml and allow to stand overnight at room temperature. Filter the insoluble matter on a No. 42 Whatman filter paper and wash thoroughly with dilute sulphuric acid. Transfer the filter paper and residue to a small beaker, cover with 20 ml of water and add 1 to 2 g of ammonium acetate. Heat the beaker on the water-bath for not less than half an hour, stirring the contents occasionally. Decant the liquid through No. 42 Whatman filter paper. Repeat the extraction with water and ammonium acetate. Transfer all the insoluble matter including

**IS : 5088 - 1982**

the filter pulp to the filter and wash throughout with warm water collecting the filtrate and washings in a 150-ml beaker. Pass hydrogen sulphide through the liquid for 10 to 15 minutes and filter the precipitated lead sulphide at once through a No 40 Whatman filter paper. Wash thoroughly but quickly with hydrogen sulphide water keeping the residue on the filter paper, if any, covered with liquid till washing is completed. Transfer the precipitate and filter paper to a tared silica-crucible. Dry, carefully ignite to sulphate, cool and weigh.

**B-5.2** Calculate the percentage of lead and lead compounds by the following formula:

$$L = \frac{W_s - W_1}{W_a} \times 100$$

where

$L$  = percent, by mass, of lead;

$W_2$  = mass, in g, of silica basin with residue;

$W_1$  = mass, in g, of silica basin taken for testing; and

$W_s$  = dry mass, in g, of testing specimen taken for testing.

## **B-6. TEST FOR COPPER AND MANGANESE AND THEIR COMPOUNDS**

**B-6.1** Test for ash of the material qualitatively with calorimetric tests for copper and manganese.

### **B-6.1.1** *Copper*

**B-6.1.1.1** Place in a test tube a portion of the ash and add 20 ml of concentrated ammonium hydroxide. Shake thoroughly to extract any copper present and filter. The residue on the filter may be saved for the manganese test described below. Add to the filtrate a few ml of sodium diethyl dithio carbamate solution, which has been prepared by dissolving 1 g of the solid salt in 5 ml of water. A brown colouration or brown precipitate shows the presence of copper.

### **B-6.1.2** *Manganese*

**B-6.1.2.1** Place in test tube the above residue of the ash and add 1 g of lead peroxime. Add slowly 10 ml of concentrated nitric acid, heat to boiling and boil for 1–2 minutes. After cooling and settling the presence of manganese is shown by a purple colouration of the supernatant liquid.

IS : 5088 - 1982

## APPENDIX C

### ( Clause 0.4 )

#### RECOMMENDED SI UNITS FOR TEXTILES

SL No.	CHARACTERISTIC	SI UNIT		APPLICATION	
		Unit(s)	Abbreviation(s)		
(1)	(2)	(3)	(4)	(5)	
1.	Length	Millimetre	mm	Fibres Samples, test specimens ( as appropriate ) Yarns, ropes, cordage, fabrics	
		Millimetre, centimetre	mm, cm		
		Metre	m		
2.	Width	Millimetre	mm	Narrow fabrics Other fabrics Samples, test specimens ( as appropriate ) Carpets, druggets, <i>DURRIES</i> ( as appropriate )	
		Centimetre	cm		
		Millimetre, centimetre	mm, cm		
3.	Thickness	Centimetre, metre	cm, m		
		Micrometre ( micron )	$\mu\text{m}$		
4.	Linear density	Millimetre	mm	Delicate fabrics Other fabrics, carpets, felts	
		Tex	tex		
		Militex	mtex		
		Decitex	dtex		
5.	Diameter	Kilotex	ktex	Yarns Fibres Filaments, filament yarns Slivers, ropes, cordage	
		Micrometre ( micron )	$\mu\text{m}$		
		Millimetre	mm		
6.	Circumference	Millimetre	mm	Ropes, cordage	
7.	Threads in fabric:			Woven fabrics ( as appropriate )	
		a) Length-wise	Number per centimetre Number per decimetre		ends/cm ends/dm
		b) Width-wise	Number per centimetre		picks/cm
			Number per decimetre		picks/dm

**IS : 5088 - 1982**

SL No.	CHARACTERISTIC	SI UNIT		APPLICATION
		Unit(s)	Abbreviation (s)	
(1)	(2)	(3)	(4)	(5)
8.	Warp threads in loom	Number per centimetre	ends/cm	Reeds
9.	Stitches in knitted fabric:			Knitted fabrics ( as appropriate )
	a) Length-wise	Courses per centimetre Courses per decimetre	courses/cm courses /dm	
	b) Width-wise	Wales per centimetre Wales per decimetre	wales/cm wales/dm	
10.	Stitch length	Millimetre	mm	Knitted fabrics, made-up items
11.	Mass per unit area	Grams per square metre	g/m <sup>2</sup>	Fabrics
12.	Mass per unit length	Grams per metre	g/m	Fabrics
13.	Twist	Turns per centimetre Turns per metre	turns/cm turns/m	} Yarns, ropes, cordage ( as appropriate )
14.	Test or gauge length	Millimetre, centimetre	mm, cm	
15.	Breaking load	Millinewton  Newton	mN  N	Fibres, delicate yarns ( individual or skeins )  Strong yarns ( individual or skeins ), ropes, cordage fabrics
16.	Breaking length	Kilometre	km	Yarns
17.	Tenacity	Millinewton per tex	mN/tex	Fibres, yarns ( individual or skeins )
18.	Twist factor or twist multiplier	Turns per centimetre × square root of tex Turns per metre × square root of tex	turns/cm × √ tex turns/m × √ tex	} Yarns ( as appropriate )

**IS : 5088 - 1982**

SL No.	CHARACTER-ISTIC	SI UNIT		APPLICATION
		Unit(s)	Abbrevia-tion(s)	
(1)	(2)	(3)	(4)	(5)
19.	Bursting strength	Newton per square centimetre	N/cm <sup>2</sup>	Fabrics
20.	Tear strength	Millinewton, newton	mN, N	Fabrics ( as appropriate )
21.	Pile height	Millimetre	mm	Carpets
22.	Pile density	Mass of pile yarn in grams per square metre per millimetre pile height	g/m <sup>2</sup> /mm pile height	Pile carpets
23.	Elastic modulus	Millinewton per tex per unit deformation	mN/tex/unit deformation	Fibres, yarns, strands

**IS : 5088 - 1982**

( Continued from page 2 )

<i>Members</i>	<i>Representing</i>
SHRI MADHUKANT PRANLAL	The Ahmedabad Textile Mills' Association, Ahmadabad
DR P. R. ROY ( <i>Alternate</i> )	
SHRI K. R. RAGHINA	The Bombay Millowners' Association, Bombay
SHRI T. RANGASWAMY	The Southern India Mills' Association, Coimbatore
SHRID. R. SHARMA	The Century Spinning & Mfg Co Ltd, Bombay
SHRI K. G. SETHURAM ( <i>Alternate</i> )	
SHRI C. G. SHROFT	Standard Mills Co Ltd, Bombay
SHRIM. T. SINGHI	Maharashtra Cooperative Spinning Mills Federation, Bombay
DR N. P. WAGLE	The Textile Corporation of Marathwada Ltd, Aurangabad
SHRI J. N. DESAI ( <i>Alternate</i> )	
SHRI D. R. YADAV	Ministry of Defence ( DGI )
MISS L. C. PATEL ( <i>Alternate</i> )	

## INTERNATIONAL SYSTEM OF UNITS (SI UNITS)

### Base Units

<i>Quantity</i>	<i>Unit</i>	<i>Symbol</i>
Length	metre	m
Mass	kilogram	kg
Time	second	s
Electric current	ampere	A
Thermodynamic temperature	kelvin	K
Luminous Intensity	candela	cd
Amount of substance	mole	mol

### Supplementary Units

<i>Quantity</i>	<i>Unit</i>	<i>Symbol</i>
Plane angle	radian	rad
Solid angle	steradian	sr

### Derived Units

<i>Quantity</i>	<i>Unit</i>	<i>Symbol</i>	<i>Definition</i>
Force	newton	N	1 N = 1 kg.m/s <sup>2</sup>
Energy	joule	J	1 J = 1 N.m
Power	watt	W	1 W = 1 J/s
Flux	weber	Wb	1 Wb = 1 V.s
Flux density	tesla	T	1 T = 1 Wb/m <sup>2</sup>
Frequency	hertz	Hz	1 Hz = 1 c/s (s <sup>-1</sup> )
Electric conductance	Siemens	S	1 S = 1 A/V
Electromotive force	volt	V	1 V = 1 W/A
Pressure, stress	pascal	Pa	1 Pa = 1 N/m <sup>2</sup>

### INDIAN STANDARDS INSTITUTION

Manak Bhavan, 9 Bahadur Shah Zafar Marg, NEW DELHI 110002

Telephones : 26 60 21, 27 01 31

Telegrams : Manaksanstha

#### *Regional Offices:*

		Telephone
Western : Novelty Chambers, Grant Road	BOMBAY 400007	89 65 28
Eastern : 5 Chowringhee Approach	CALCUTTA 700072	27 50 90
Southern : C. I. T. Campus	MADRAS 600113	41 24 42
Northern : B69, Phase VII	S. A. S. NAGAR (MOHALI) 160051	8 78 26

#### *Branch Offices:*

'Pushpak', Nurmohamed Shaikh Marg, Khanpur	AHMADABAD 380001	2 03 91
'F' Block, Unity Bldg, Narasimharaja Square	BANGALORE 560002	22 48 05
Gangotri Complex, Bhadbhada Road, T. T. Nagar	BHOPAL 462003	6 27 16
22E Kalpana Area	BHUBANESHWAR 751014	5 36 27
5-8-56C L. N. Gupta Marg	HYDERABAD 500001	22 10 83
R14 Yudhister Marg, C Scheme	JAIPUR 302005	6 98 32
117/418 B Sarvodaya Nagar	KANPUR 208005	4 72 92
Patliputra Industrial Estate	PATNA 800013	6 28 08
Hantex Bldg (2nd Floor), Rly Station Road	TRIVANDRUM 695001	32 27

Printed at New India Printing Press, Khurja, India