

2

THIS DOCUMENT AND THE INFORMATION CONTAINED IN IT ARE PROPRIETARY AND CONFIDENTIAL TO OFT. NO PERSON OR ENTITY IS ALLOWED TO COPY, REPRINT, REPRODUCE OR PUBLISH ANY PART OF THIS DOCUMENT, NOR DISCLOSE ITS CONTENTS TO OTHERS, NOR MAKE ANY USE OF IT, NOR ALLOW OR ASSIST OTHERS TO MAKE ANY USE OF IT UNLESS BY THE PRIOR WRITTEN EXPRESS AUTHORIZATION OF OFT AND THEN ONLY TO THE EXTENT AUTHORIZED. COPYRIGHT-OFT.

DWG NO 074312A-00

SH 1

1

SHEET REV RECORD	
ALL SHEETS ARE THE SAME REVISION	

REVISION RECORD				
REV	ECO	DESCRIPTION	DATE	APVD
01		Freeze	08-Aug-13	
02		Freeze	28-Nov-13	
03		Restricted	28-May-14	L. Goldshtein
--		Identical To Previous Released	09-Apr-18	L. Goldshtein

NOTES:

- INTERPRET THIS DRAWING IAW ASME Y14.100M.
- MATERIAL: CRES BAR TYPE 303 PER ASTM-A-582.
- DEBURR AND REMOVE SHARP EDGES, APPROX. 0.2X45 Deg.
- GENERAL TOLERANCES ACCORDING TO ISO 2768-c.
- FINISH: PASSIVATION TREATMENT PER AMS-2700 METHOD 1 TYPE 6.
- QUALITY ASSURANCE PROVISIONS:
  - QUALITY ASSURANCE PROVISIONS FOR THIS ITEM PER RDMQD00012P.
- PARENTHETICAL FIGURES ARE FOR REFERENCE ONLY.
- PACKAGING AND PACKING: THE FINISHED PART SHALL BE PRESERVED AND PACKAGED IN ACCORDANCE WITH MANUFACTURER'S BEST COMMERCIAL PRACTICE.
- IDENTIFY PER MIL-STD-130 PARA 4.1.B, BY LABELING ITS CONTAINER WITH THE PART NUMBER. CHARACTERS MINIMUM TEXT HEIGHT 1.25 MM.

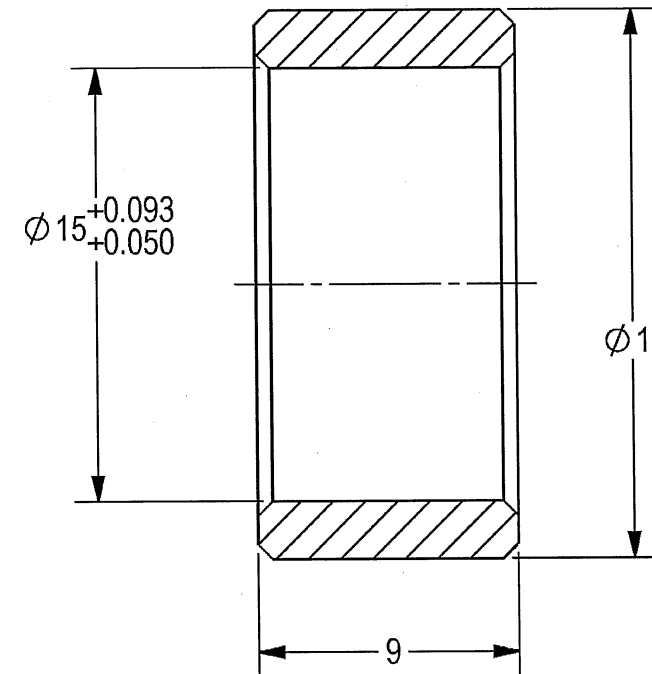

B

B

A

A

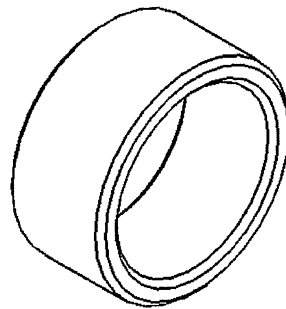

(WEIGHT APPROX.: 0.008 Kg)

SEE ATTACHED MEDIA

3.2

UNLESS OTHERWISE SPECIFIED		SIGNATURE	DATE	<b>ORDNANCE FACTORY</b> TIRUCHIRAPPALLI	
DIMENSIONS ARE IN MM PER ASME Y14.5-2009		DRAWN	1/9/20		
TOLERANCES		CHECKED		TITLE	
LINEAR	ANGULAR	HOS/DDO	3/9/10	FOR: COCKING MECHANISM	
SEE NOTE 4	SEE NOTE 4	OFFICER/PRODN		OF: 12.7MM SRCG	
1st. ANGLE PROJECTION		OFFICER/QC		SIZE	CAGE CODE
		OFFICER/DDO		B	2291A
SURFACE TEXTURE IN Micro Meter				DWG NO	074312A-00
PROJECT OFFICER				SCALE	4:1
				AUTOMATED DRAWING (SW)	SHEET 1 OF 1
PLM Control		EPDM DRAWING REV.	EPDM MODEL REV.	EPDM MODEL STATUS	EPDM MODEL NAME
				WIP	074312A-001 SPACER_ROTOR

2