

M 1808

NOTES:

- APPLICABLE SPECS/STANDARDS:  
A. ASME Y14.5M-1994
- MATERIAL:  
A. WROUGHT MATERIAL: STEEL ASTM A322 OR A331, 8645, 8740, 8640, 8650.  
B. PRECISION CASTING: STEEL, MIL-S-22141, IC8640, IC4340; TENSILE TEST SHALL NOT APPLY. CASTING SHALL BE IN ACCORDANCE WITH CLASS 2, GRADE B OF SAE AMS 2175.
- FINAL PROTECTIVE FINISH:  
FINISH 5.3.1.2 OR 5.3.2.2 OF MIL-STD-171.
- HEAT TREATMENT: HEAT TO 829° TO 843 °C. OIL QUENCH. TEMPER ONE HOUR MINIMUM AT HEAT TO HARDNESS RH A74.5-78.
- BREAK EDGES 0.076 + 0.305 UNLESS OTHERWISE SPECIFIED.
- FINISH  $\sqrt{32}$  ALL OVER.
- PRIOR TO FIT AT ASSEMBLY, SEE RECEIVER ASSEMBLY 6535480.

REVISIONS				
ZONE	REV.	DESCRIPTION	DATE	APPROVED
	A	CREATE DRAWING	12/11/2015	G. HERSHBERGER
C2	B	CHANGED PROFILE TOLERANCE TO .002 FROM .005. SEE DCR #113.	3/14/2018	B.SUSNIK

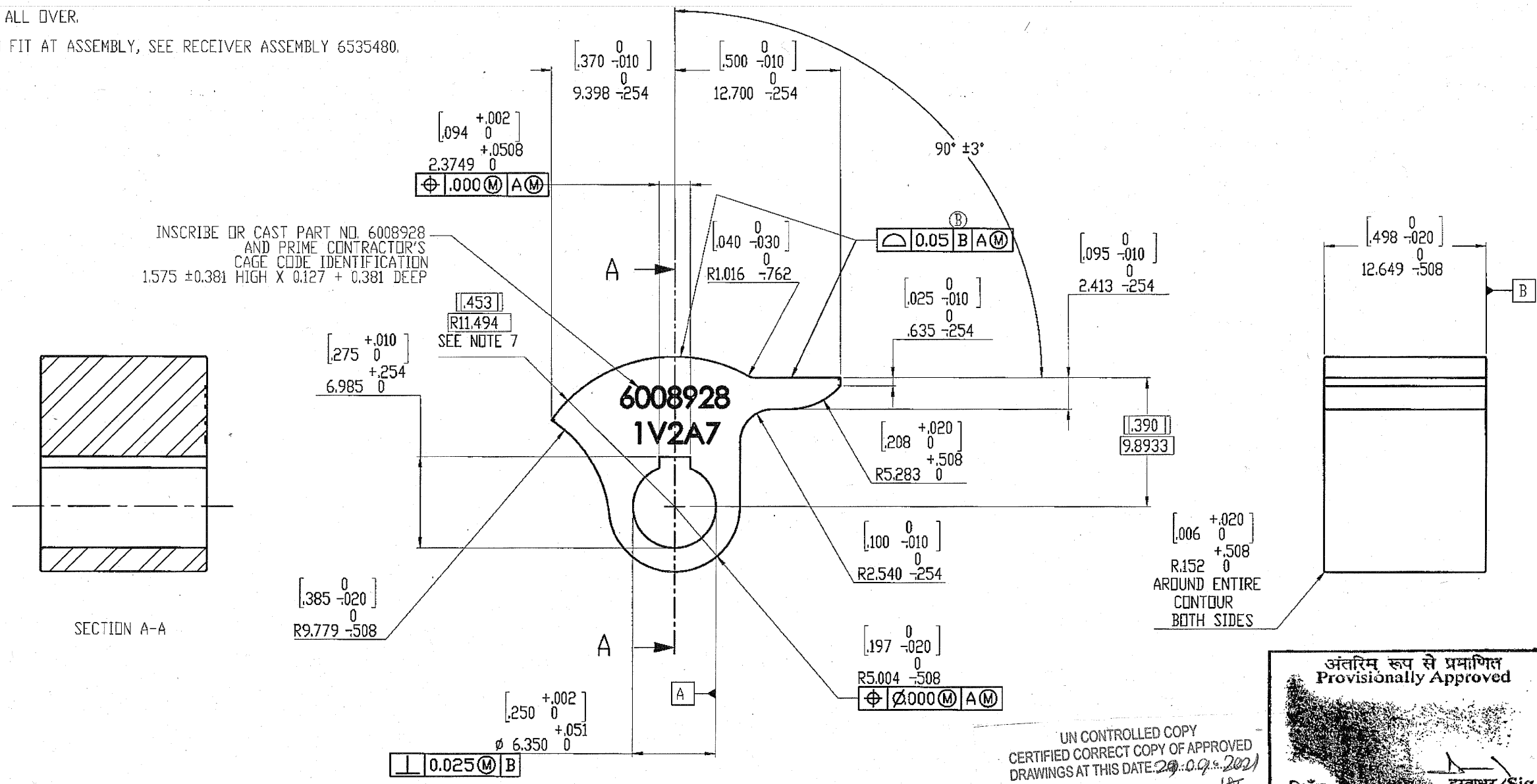

UN CONTROLLED COPY  
CERTIFIED CORRECT COPY OF APPROVED  
DRAWINGS AT THIS DATE: 20-07-2021  
DESIGN & DRAWING OFFICE,  
ORDNANCE FACTORY, TIRUCHIRAPPALI - 620 016

अंतरिम रूप से प्रमाणित  
Provisionally Approved  
दिनांक 24 AUG 2021  
हस्ताक्षर/Sig for (Gnd/AFI)

<b>ITAR CONTROLLED</b> <small>THIS DOCUMENT IS CONTROLLED UNDER THE ITAR. IT MAY NOT BE PROVIDED TO A NON-US RESIDENT WITHOUT THE WRITTEN APPROVAL OF THE U.S. GOVT. VIOLATIONS WILL RESULT IN CIVIL OR CRIMINAL PENALTIES.</small> <small>PROPRIETARY AND CONFIDENTIAL. THE INFORMATION CONTAINED IN THIS DRAWING IS THE SOLE PROPERTY OF OHIO DRUMMAGE WORKS, INC. ANY REPRODUCTION IN PART OR AS A WHOLE WITHOUT THE WRITTEN PERMISSION OF OHIO DRUMMAGE WORKS, INC. IS PROHIBITED.</small>	<small>UNLESS OTHERWISE SPECIFIED DIMENSIONS ARE IN MILLIMETERS ALL THREAD DIM ARE IN INCHES</small> TOLERANCES: FRACTIONAL ANGULAR RICH 4° BEAD TWO PLACE DECIMAL .025 THREE PLACE DECIMAL .0127 INTERPRET GEOMETRIC TOLERANCING PER MATERIAL FINISH DO NOT SCALE DRAWING	NAME: PHD DATE: 11/27/15 CHECKED: ENG APPR. NFG APPR. G.A. COMMENTS:	OHIO DRUMMAGE WORKS, INC. LATCH, COVER, DDW50BMG SIZE: C 6008928 SCALE: 4:1 WEIGHT: SHEET 1 OF 3	
	DRAWN: PHD DATE: 11/27/15	CHECKED: ENG APPR. NFG APPR.	G.A. COMMENTS:	REV: B
	DRAWN: PHD DATE: 11/27/15	CHECKED: ENG APPR. NFG APPR.	G.A. COMMENTS:	REV: B
	DRAWN: PHD DATE: 11/27/15	CHECKED: ENG APPR. NFG APPR.	G.A. COMMENTS:	REV: B

M 1308

PN: 6008928  
SCALE 20X

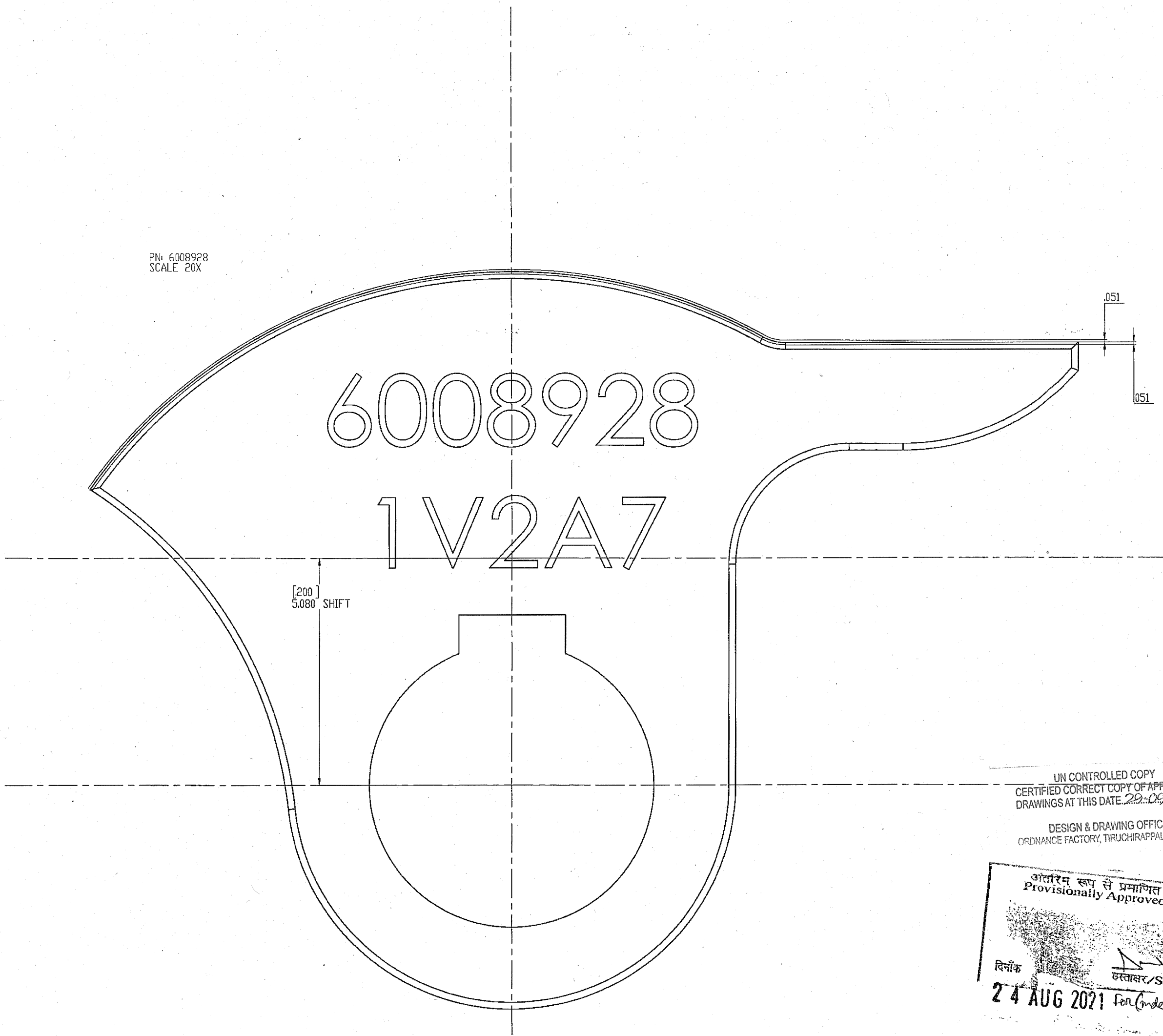

UN CONTROLLED COPY  
CERTIFIED CORRECT COPY OF APPROVED  
DRAWINGS AT THIS DATE: 29.09.2021  
DESIGN & DRAWING OFFICE,  
ORDNANCE FACTORY, TIRUCHIRAPPALI-620 016.

अंतरिम रूप से प्रमाणित  
Provisionally Approved  
दिनांक  
हस्ताक्षर/Sig  
24 AUG 2021 For (mde/AA)

M1308

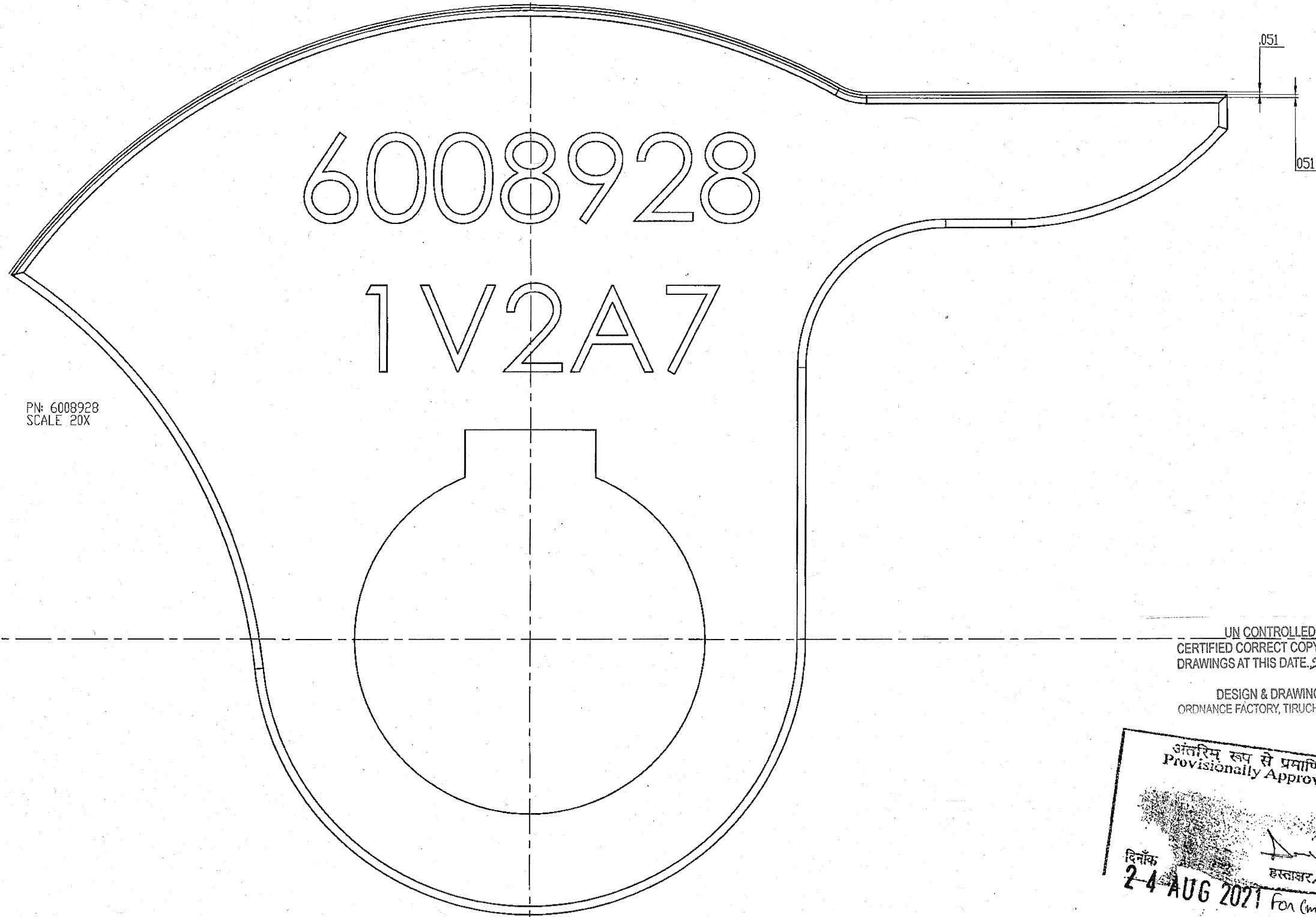

UN CONTROLLED COPY  
CERTIFIED CORRECT COPY OF APPROVED  
DRAWINGS AT THIS DATE. 20.08.2021

DESIGN & DRAWING OFFICE,  
ORDNANCE FACTORY, TIRUCHIRAPPALI - 620 016.

अंतरिम रूप से प्रमाणित  
Provisionally Approved

दिनांक  
2-4 AUG 2021 For (mdc/AP)

हस्ताक्षर/Sig