

THIS DOCUMENT AND THE INFORMATION CONTAINED IN IT ARE PROPRIETARY AND CONFIDENTIAL TO OFT. NO PERSON OR ENTITY IS ALLOWED TO COPY, REPRINT, REPRODUCE OR PUBLISH ANY PART OF THIS DOCUMENT, NOR DISCLOSE ITS CONTENTS TO OTHERS, NOR MAKE ANY USE OF IT, NOR ALLOW OR ASSIST OTHERS TO MAKE ANY USE OF IT UNLESS BY THE PRIOR WRITTEN EXPRESS AUTHORIZATION OF OFT AND THEN ONLY TO THE EXTENT AUTHORIZED. COPYRIGHT-OFT.

SHEET REV RECORD
ALL SHEETS ARE THE SAME REVISION

REVISION RECORD				
REV	ECO	DESCRIPTION	DATE	APVD
02		Freeze	19-Nov-12	
03		Freeze	01-Jan-14	
04		Restricted	09-Jan-14	
05	VY116/00	Restricted	28-Dec-14	D. Nave
--	T00064	Identical To Previous Released	09-Apr-18	L. Goldshtein

NOTES:

- INTERPRET THIS DRAWING IAW ASME Y14.100M.
- MATERIAL: STEEL ALLOY BAR SAE 4130 PER SAE-AMS-S-6758 OR SAE 4340 PER SAE-AMS-S-5000. (EQUIVALENT MATERIAL IS PERMITTED AFTER ELBIT APPROVAL).
- HEAT TREATMENT: QUENCH AND TEMPER ENTIRE PART; HARDNESS 35±4 HRC PER AMS 2579/1
- DEBURR AND REMOVE SHARP EDGES APPROX. 0.3X45°.
- GENERAL TOLERANCES ACCORDING TO ISO 2768-m.
- PHOSPHATE COATING TYPE M, CLASS 2, 0.005-0.010 MM THICK PER MIL-DTL-16232.
- THE DIMENSIONS ARE BEFORE COATING.
- QUALITY ASSURANCE PROVISIONS:
 - QUALITY ASSURANCE PROVISIONS FOR THIS ITEM PER RDMQD00012P.
 - MAJOR CHARACTERISTICS NRS 101 AND 102
- PACKAGING AND PACKING: THE FINISHED PART SHALL BE PRESERVED AND PACKAGED IN ACCORDANCE WITH COMMERCIAL PRACTICE.
- IDENTIFY PART PER MIL-STD-130 RUBBER STAMP WITH EPOXY INK PER A-A-56032 TYPE II IN CONTRASTING COLOR. CHARACTERS MINIMUM TEXT HEIGHT 1.25 MM. LOCATION APPROX. AS SHOWN.

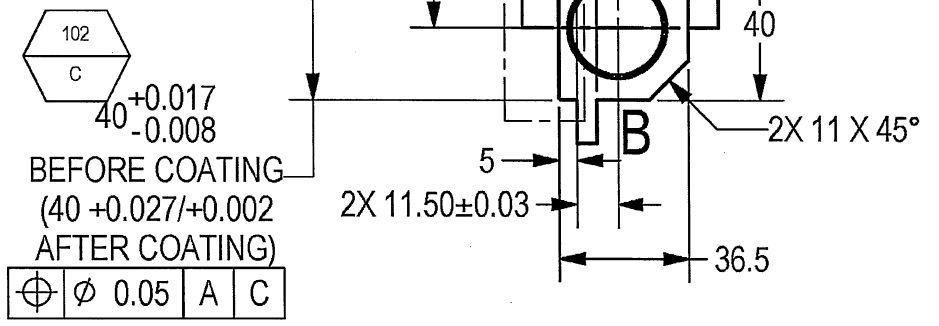
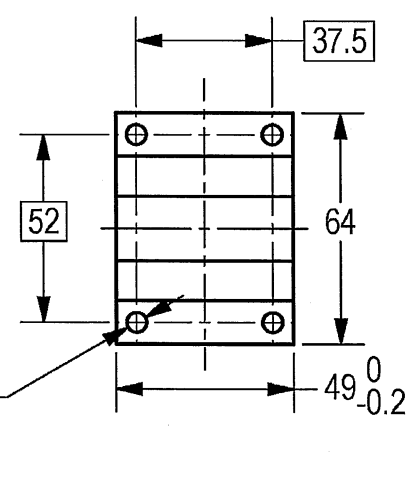
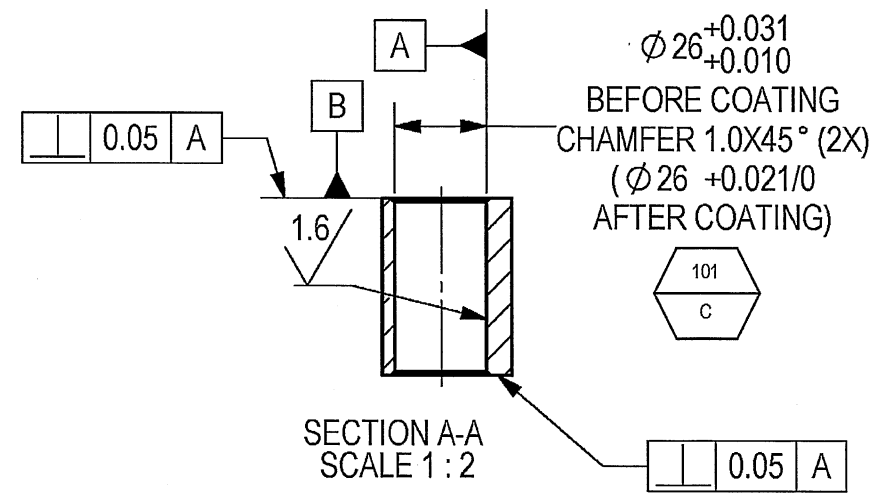
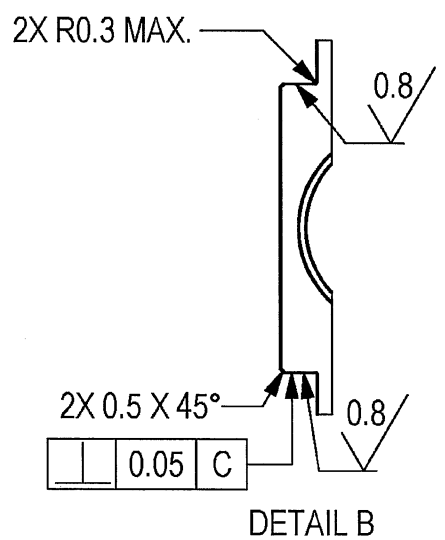

SEE ATTACHED MEDIA

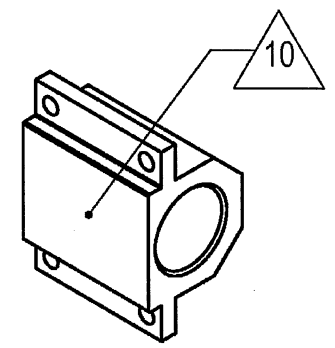

(WEIGHT APPROX.: 0.361 Kg.)

UNLESS OTHERWISE SPECIFIED		SIGNATURE	DATE	ORDNANCE FACTORY TIRUCHIRAPPALLI	
DIMENSIONS ARE IN MM PER ASME Y14.5M-1994		DRAWN	1/9/20		
TOLERANCES		CHECKED		TITLE	
LINEAR	ANGULAR	HOS/DDO	3/9/20	BOLT HOUSING	
SEE NOTE 5	SEE NOTE 5	OFFICER/PRDN		FOR: ELEVATION & TRAVERSE ASSY	
1st ANGLE PROJECTION		OFFICER/QC		OF: 12.7MM SRCG	
		OFFICER/DDO	3/9	SIZE	CAGE CODE
SURFACE TEXTURE IN Micro M				B	2291A
				DWG NO	064405A-00
PROJECT OFFICER				SCALE 1:2	AUTOMATED DRAWING (SW)
					SHEET 1 OF 1

PLM Control