

DRG. NO. 30 P 3062

DIMENSIONS ARE IN mm.
 UNTOLERATED DIMNS. AS PER IS : 2102 (MED)

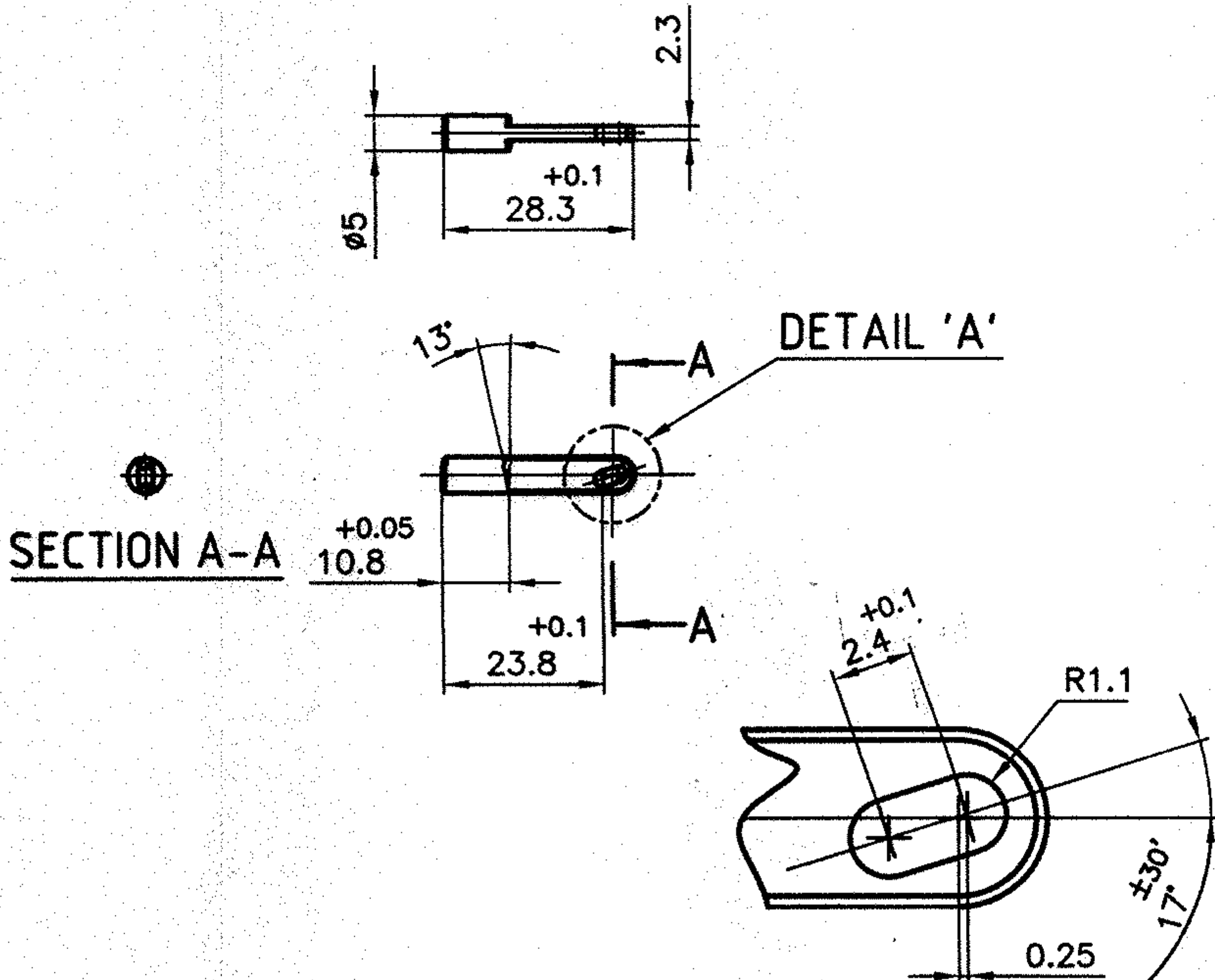

ENLARGED VIEW 'A'
 SCALE: 5:1

MATERIAL : IS: 1875 - 1992, CLASS - 4, DESIGNATION - 45C8.
(OR) BS: 970, PART - 1, 1983, GRADE - 080M40.

MATERIAL : En 8 (OR) En 9
HARDNESS: 37 - 42 HRC

PROTECTIVE FINISH : PHOSPATED TO SPECIFICATION. JSS : 0465-01-1988
CLASS-I (ACCELERATED) OIL FINISH.

PART NO.	DESCRIPTIONS	NO OFF	MATERIAL	TREATMENT	REMARKS
	SIGNATURE & DATE.		SUB: PIN ALIGNING		SCALE 1:1
	TRACED		FOR: HAMMER SUB ASSY		STORE DRG.NO.
	DRAWN <i>J. Venkatesh</i>		OF: 40mm. MGL		---
	CHECKED		DES. REF. NO.		OPERATION NO.
	HOS/D&DO <i>J.P.</i>		DRG. No.: 30 P 3062		---
	MODL OFFICER/ FOR MGL <i>HP</i>		 ORDNANCE FACTORY TIRUCHIRAPPALLI-16.		SHEETS: 1
	OFFICER/ D&DO				SHEET No.: 1
AMENDMENTS	SIG. & DATE	APPROVED ON: 25/02/2015			