

Kuvassa esitettyjen osien valmistus on suoritettava siten, että osien
 ja niiden osien valmistus on suoritettava siten, että osien
 ja niiden osien valmistus on suoritettava siten, että osien
 ja niiden osien valmistus on suoritettava siten, että osien

DC 34454-A

APPD. FOR CQA(A)
 ANSP. CQA(A), KIRKEE

ANSP. D.O. SIG
 ANSP. ZONE

PREVIOUS DC. Nos. 34454-A, 35138-A, 35225-A,
 35300-A, 35374-A & 35334-A

AUTHORITY DRG. SEALED- 19-09-98 (PROV.)
 DATE

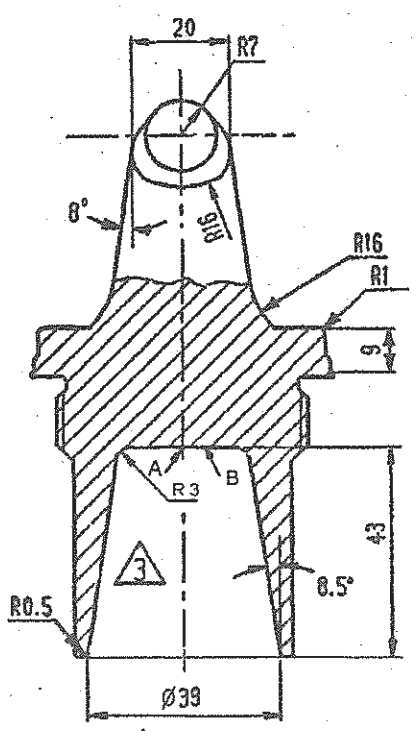
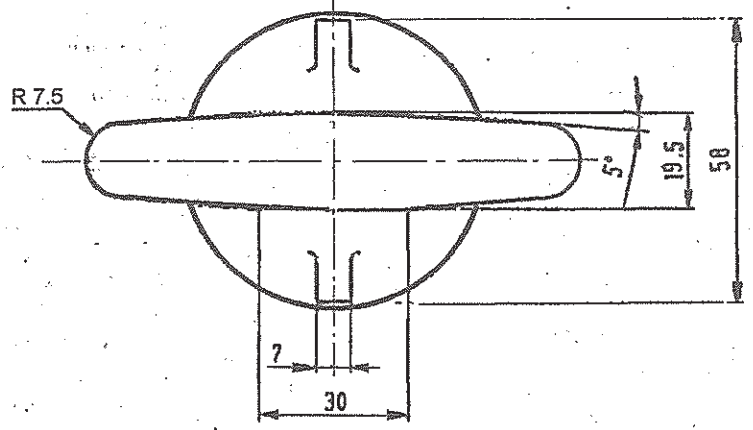
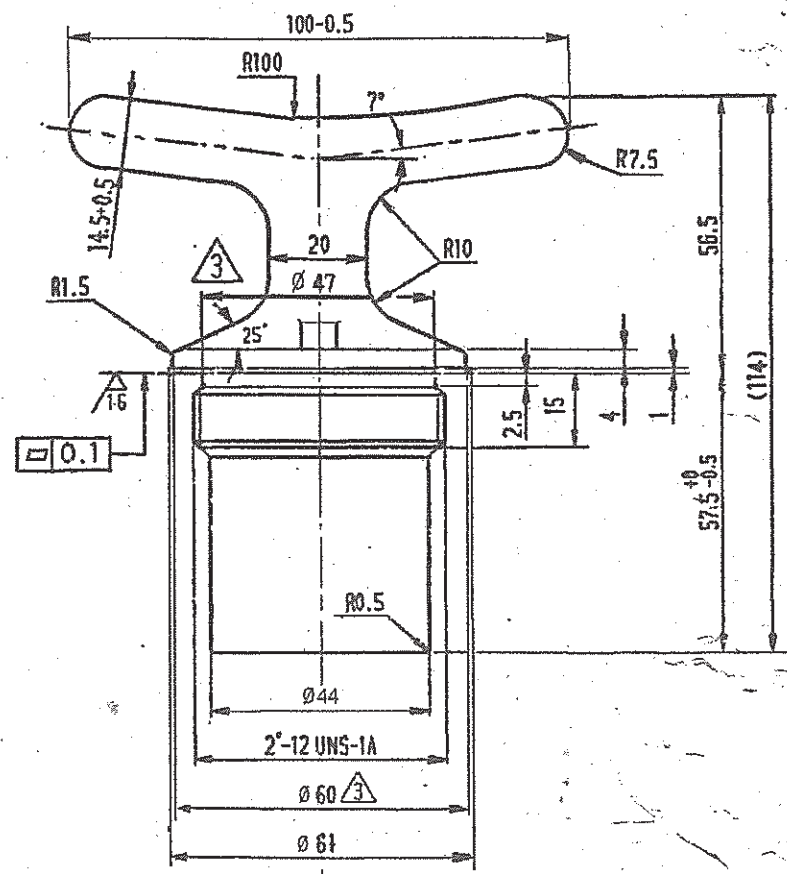

Kulor: W4 - 27 - 759 (grd)
 Colour: W4-27-759 (grey)

Tolerans Basistil och tolerans	at ISO Tolerances acc. to ISO
Grundmått och tolerans	Grensvärden. Limit deviation övre: upper undre: lower

NOTE:-
 SUITABLE VENT HOLE BE PROVIDED AT CENTRE TO AVOID SHRINKAGE/BLOW HOLE AT POSITION MARKED 'A'

(b) CONTRACTOR'S INITIALS AND DATE OF MANUFACTURE (MONTH/YEAR) BE STAMPED AT POSITION MARKED 'B' ON SURFACE.

INDIGENOUS EQUIVALENT MATL.
 * (c) POLYPROPYLENE TO IPCL Gy M 3030 OR POLYPROPYLENE GRADE SM 30 M INJECTION MOULDING GRADE.
 ** IS-5-78

COPY ISSUED BY CDD/CEFAJ
 प्रतिलिपि जारी की जायेगी/को. एक प्र. ज.
 इस को गड्डे है।
 दिनांक: 24/8/22
 Date: 24/8/22 for HOC/CDD

Viktskrovse 0808 351
 Weight requirements see 0 808 351

Teknisk bestemmelse for kop 0 808 351
 Technical procurement specification : 0 808 351

3	C2	AO 39042423	43 var 46; R3 var R14, 8.5° var 10°	870623	Gup
3	C5		Ø60 var Ø58; Ø47 Lillk.	870623	Gup
2	C2	AO 39041091	Ändrad innergeometri	870522	Gup
1	B1-B4	AO 39041079	Ändrad kulör, text tillk.	870504	Gup

Andr. nr Rev. No	Läge Zone	AO nr och ändringsbeskrivning Revision order No and description of the revision	Datum Date	Godkänd Approved
Där ej annat erogetts gäller <i>Unless otherwise stated the following applies</i>				
Mått före ytbehandling Dimension before surface treatment	Skarpa kanter brutna Sharp edges broken	Kontroll Checked	Material	Material
Ytgenomhet R _a µm Surface roughness R _a µm	Fäskastnader Fillet radi	Åld Date	Ungångsväte Basic material	Ungångsväte Basic material
Toleranser för klippning och gasbearbetning enligt T2-3 Tolerances for clipping and flame-cutting acc. to T2-3	Bearbetningstoleranser ent. T2-2 klass. Machining tolerances acc. to T2-2 class.	Datum Date	Föregående ritning Previous drawing	Vikt Weight kg
	Svetsstoleranser ent. T2-4 klass. Welding tolerances acc. to T2-4 class.	Skala Scale		
Ytbehandlad Surface treated		Vyplacering Prop. method		
Benämning Denomination	Lufthandtag Lifting plug	Ritning nr Drawing No		Senaste ändr. Latest rev
		5 191 856		3

BOFORS