

19100-0001 D.S.CAT. 1005-001613

DIMNS ARE IN mm.

NOTE
 WHERE TOLERANCES ARE NOT SHOWN DIMENSIONS
 IN WHOLE NUMBER OR WITH ONE DECIMAL PLACE
 ± 1.27 mm. DIMENSIONS WITH TWO DECIMAL PLACE
 ± 0.13 mm.

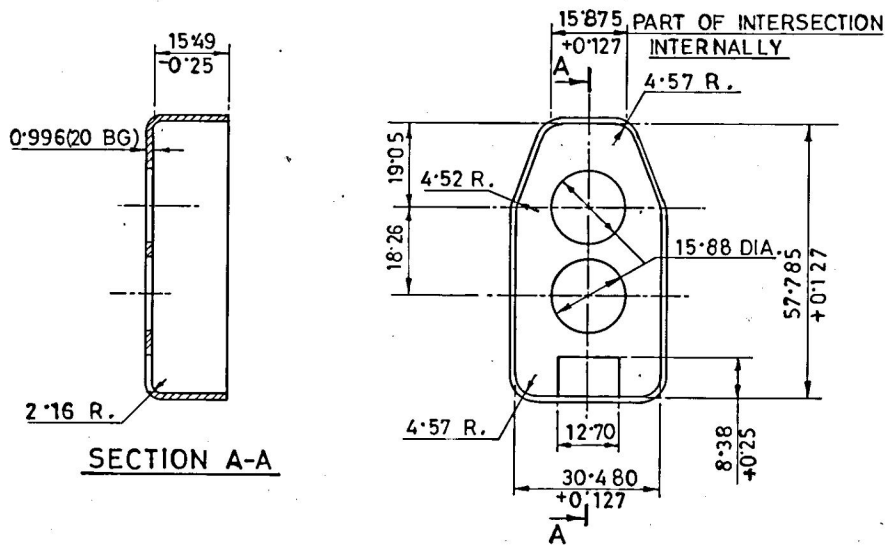

ALT. MATERIAL :-
 STEEL IS: 4030-1967 C 10% AND Mn. 50%
 TEMPER 4 & 5.

PROTECTIVE FINISH:-
 EXTERNAL SURFACE:- PHOSPHATE TO SPECN.
 JSS-0465-01:1988 CLASS I, PAINT RFU
 FINISHING AMMUNITION STOVING BLACK
 SPRAYING FOR SMALL ARMS TO SPECN.
 JSS-8010:37.

INTERNAL SURFACE:- PHOSPHATE TO SPECN.
 JSS-0465-01:1988 CLASS-I, OIL FINISH.

FOR EXPLANATION OF DETAILS WHEREVER NOT
 SPECIFIED REFER D. D. NOTE SHEET NO3 (LATEST-
 ISSUE).

NOTE:- FOR SPECN. LATEST ISSUE SHOULD BE
 FOLLOWED.

METRIC

				DRN	CHD	TRD	Shand	COMP	Rbmla	ASSY.	1005-001594 1005-001595 & 1005-001596
				SCALE:- 1:1		EST. MASS.		MFG./IN SP. INSTRUCTIONS.			
				DT. 21.8.96.		APPROVED. DT. 19.6.67		NEG. RE-TRACED		AHS P	
				MATERIAL		STEEL BS: 1449 PT.1. CS-3 SEC-2		DGNR'S REF.		ARDE 657/264	
DATE AUTHY		BRIEF RECORD		ZONE		I/C D.O.		G. O.		PART NO	
SEALED:- D.C. 15025-SA, DT. 10.2.77						SIGN.		H.T./HARDNESS		DRG. NO.	
NOMENCLATURE		FERRULE, BUTT		PROTECTIVE FINISH.		AS ABOVE		D.S.CAT. NO.		1005-001613	