

DRG. INDIANISED BASED ON RUSSIAN ORIGINAL ISSUE - NIL.

DRAWING NUMBER  
**613 44 061**

No part of these drawings may be reproduced in any form without prior permission in writing of OFM.

**EXPLANATORY NOTE:-**

B. REFERENCE MATERIAL QUOTED AND REFERENCE NOTE 3.  
COLD-DEFORMED TUBE WITH INNER HEXAGON PROFILE OF SIZE B  $22^{+0.35}_{+0.05}$  mm WITH CONJUGATION RADIUS 0.5 TO 2.0mm AS PER Ty 14-3-232 -74 OF CHROME STEEL OF GOOD QUALITY GRADE 40X GOST 4543 -71.

a) CHEMICAL COMPOSITION:- AS PER STEEL GRADE 40X GOST 4543 -71.

CONTENT OF ELEMENTS %					
C	Si	Mn	Cr	S	P
0.36-0.44	0.17-0.37	0.50-0.80	0.80-1.10	0.035	0.035
MAXIMUM					

RESIDUAL CONTENT OF COPPER AND NICKEL SHOULD NOT EXCEED 0.30% EACH.

b) MECHANICAL PROPERTIES:-

TENSILE STRENGTH Kgf/mm <sup>2</sup>	YIELD POINT Kgf/mm <sup>2</sup>	ELONGATION %	REDUCTION IN AREA %	IMPACT STRENGTH Kgm/Cm <sup>2</sup>
100	80	10	45	6
MINIMUM				

Received vide letter No.  
OFM/TDS/TA/07A dt. 22-11-2010  
OFM 13300

ALT. MATL: CHROME MOLYBDENUM STEEL 40 (Cr 1 Mo 28) TO IS: 5517-69 OR EN-19A TO BS.970

INDICATIVE DRAWING

These drawings are only for reference. Actual drawings may be different and shall be issued at the time for procurement.

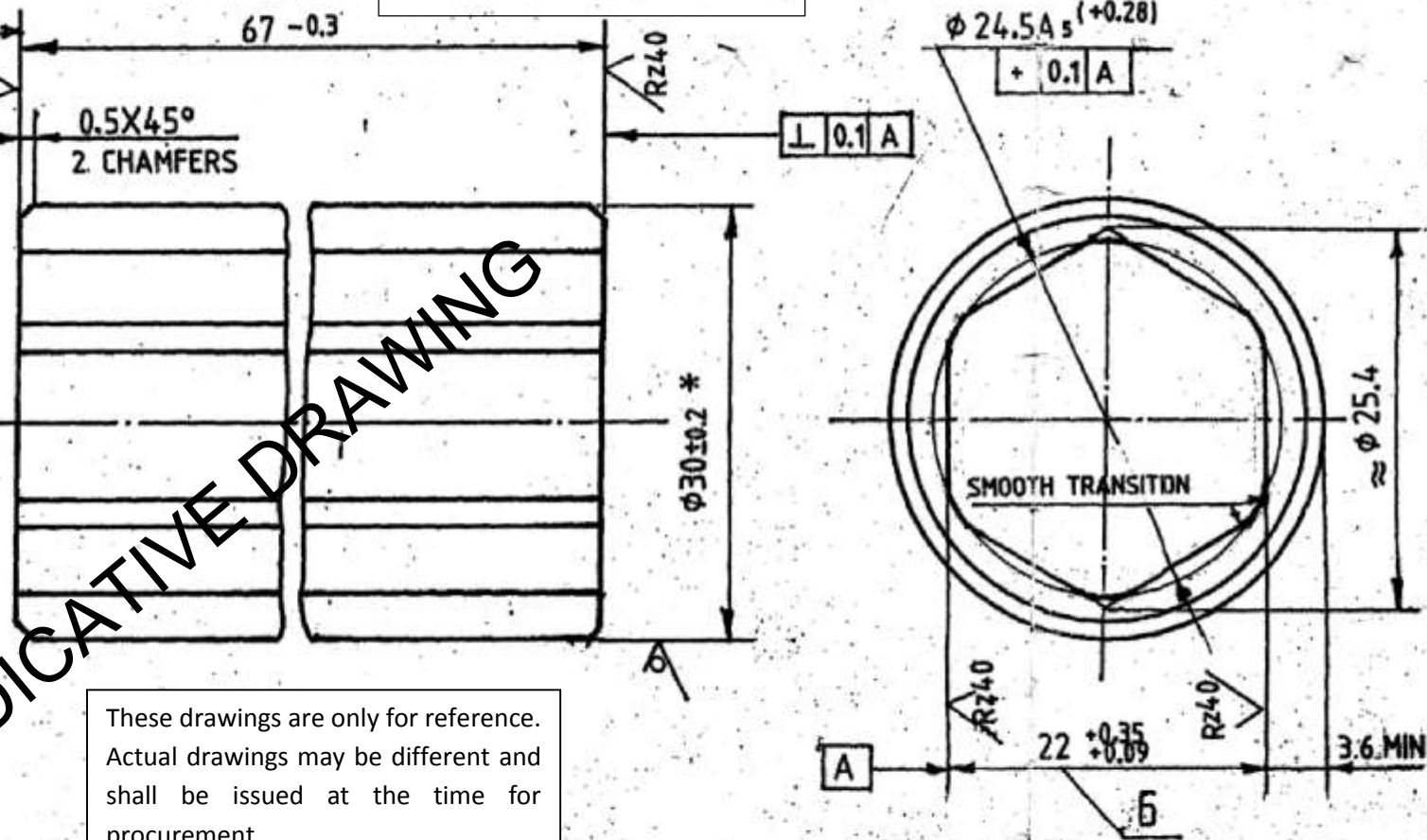

- ① 35.5.....45.5 HRC<sub>2</sub>
1. HRC 34 TO 44 HARDNESS TO BE CHECKED ON CYLINDRICAL SURFACE. FLAT NOT EXCEEDING 0.5mm IN DEPTH AND 15mm IN LENGTH, POSITIONED PARALLEL TO THE FACE SURFACE AT A DISTANCE OF ATLEAST 15mm FROM ANY FACE, IS ALLOWED. DURING REPEATED HEAT TREATMENT SECOND FLAT IS ALLOWED.
2. AFTER HEAT TREATMENT DIMENSIONS B MAY BE INCREASED TO 22.47mm.
3. PIPE IS DELIVERED WITH INNER HEXAHEDRON PROFILE AS PER Ty 14-3-232 -74.
4. MINIMUM VALUE OF DIMENSION B AND CORRECTNESS OF SHAPE OF HEXAGONAL HOLE IS TO BE CHECKED WITH HEXAGONAL GAUGE 22.08<sub>-0.01</sub> x 24.25<sub>-0.02</sub> x 20mm.
5. \*DIMENSION FOR REFERENCE.
6. NOT TO BE MARKED.
7. THE REST OF THE TECHNICAL REQUIREMENTS ARE IN COMPLIANCE WITH APPENDIX No3, Ty 105 42 -77.

PILOT SAMPLE SHOULD BE APPROVED BY A H S P BEFORE BULK PRODUCTION

EST WT 0.153 Kg TO BE STAMPED OR MARKED WHERE INDICATED THUS # ( LETTERS )

ALL SHARP EDGES AND CORNERS TO BE REMOVED UNLESS OTHERWISE STATED MACHINED CORNERS TO HAVE R OUTSIDE R INSIDE EQUIVALENT CHAMFERS ARE PERMISSIBLE.

DRN	<i>[Signature]</i>	MATERIAL:-	STEEL 40X GOST 4543 -71	USED ON	613 44 057 Cb
CHD	<i>[Signature]</i>	SEE PARA 3			
TCD	<i>[Signature]</i>				
APPD	<i>[Signature]</i>	CONTROLLERATE OF INSPECTION (HEAVY VEHICLES) AVADI			
DATE	01-03-86				
SCALE	2:1				
DIMENSIONS IN mm		TOLERANCE ON DIMNS UNLESS OTHERWISE STATED IS: 2102-69		TITLE <b>SHORT BUSHING</b>	
ALL THREADS TO CONFORM TO					
1	1-7-91	NOTN. N31-B9 AL.12/BK.3	D S CAT NUMBER	DRAWING NUMBER 613 44 061	