

DRG NO. 30P 1500

DIMENSIONS ARE IN mm.

UNTOLERATED DIMNS. AS PER IS : 2102 (MED)

MARK DRAWING No.

UN CONTROLLED COPY
 CERTIFIED CORRECT COPY OF APPROVED
 DRAWINGS AT THIS DATE. 11/03/22
S. Venkatesh
 11/3
 DESIGN & DRAWING OFFICE,
 ORDNANCE FACTORY, TIRUCHIRAPPALI - 620 016.

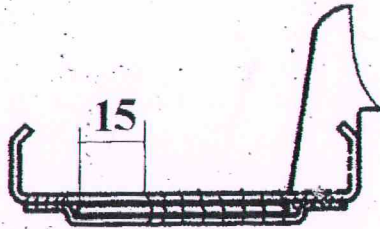

COVER MANUAL RELEASE.
 30P 1501

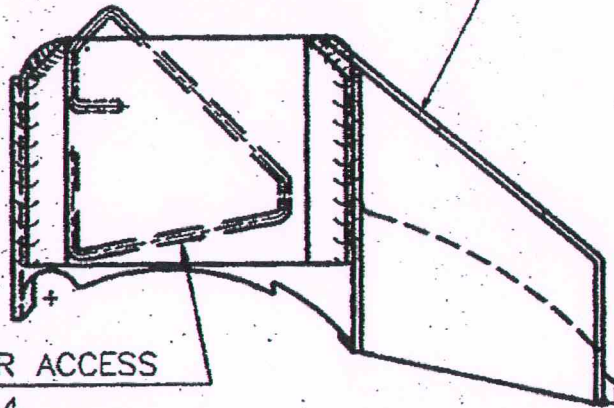

SPRING COVER ACCESS
 30P 1504

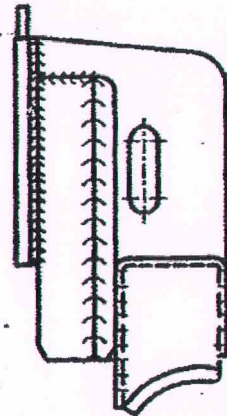

COVER ACCESS FRONT.
 30P 1502

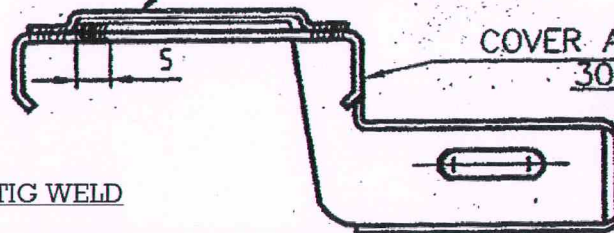

COVER ACCESS REAR.
 30P 1503

((((((((TIG WELD

PROTECTIVE FINISH:-
PHOSPHATED TO SPECN. JSS:0465-01-1988
CLASS-1 OIL FINISH.

PART NO.	DESCRIPTIONS	NO OFF	MATERIAL	TREATMENT	REMARKS
	SIGNATURE & DATE	SUB: COVER COMBINATION ASSY.			SCALE 2:1
TRACED	<i>S. Venkatesh</i>	FOR: BARREL AND FRAME GROUP			STORE DRG.NO.
DRAWN		OF: 40mm MGL			OPERATION NO.
CHECKED	<i>S. Venkatesh</i>	DES. REF. NO.			SHEETS: 1
HOS/D&DO		DRG. No.: 30P 1500			
NODAL OFFICER	<i>S. Venkatesh</i>	ORDNANCE FACTORY TIRUCHIRAPPALI-16.			SHEET No.: 1
D&DO		APPROVED ON. 25/02/2015			

DA NO. 33/18
 25/10/18
 AMENDMENTS
 SIG. & DATE



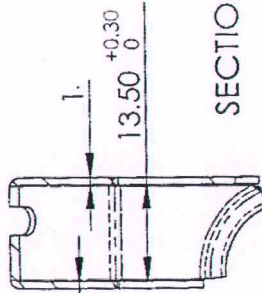

SECTION D-D

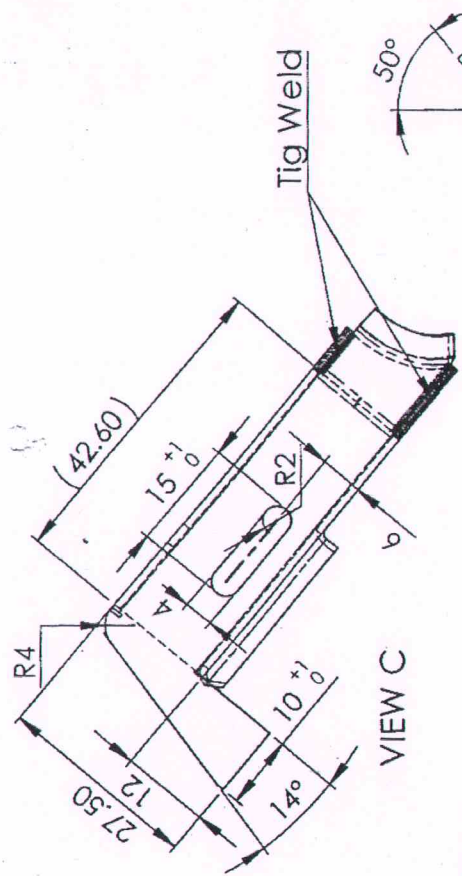
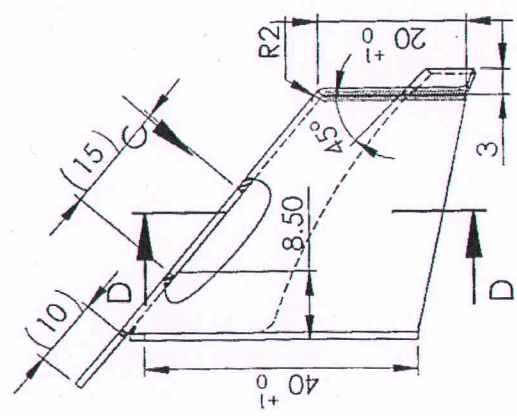

VIEW C

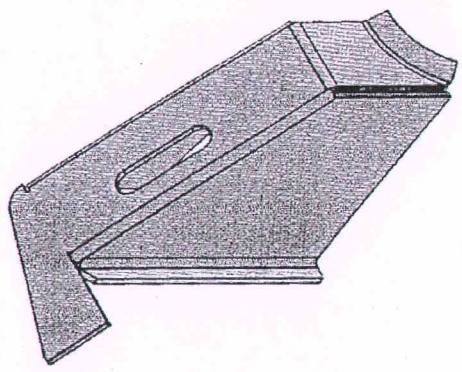
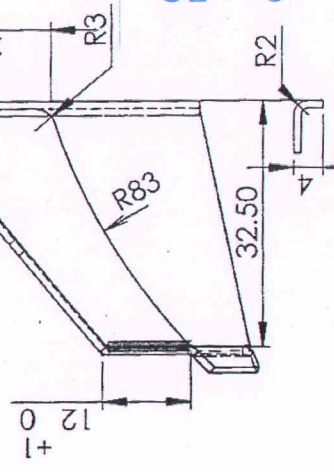
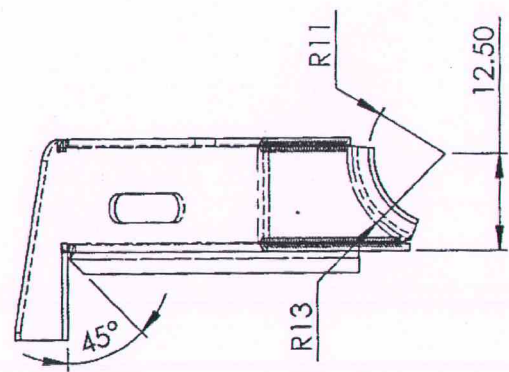

UN CONTROLLED COPY
 CERTIFIED CORRECT COPY OF APPROVED
 DRAWINGS AT THIS DATE 15/12/2018
[Signature]
 DESIGN & DRAWING OFFICE,
 ORDNANCE FACTORY, TIRUCHIRAPPALI - 620 016.

Material :- Steel Sheet 1.0mm :

IS:2507-1975, Gr-1 Design.45C8
 (or) BS:1449,Part-1 1983, Grade-CS-40 (or)CS50

Hardness : 320-360 HV

Dimensions are in mm
 Untolerated Dimensions as per IS:2102 (Medium)

Protective Finish : After assy.

	TRACED	SIGNATURE & DATE.
	DRAWN	<i>[Signature]</i>
	CHECKED	
	OIC/D&DO	<i>[Signature]</i>
	OFFICER/ PRODN.	
	DIV.OFFICER/ D&DO	
	APPROVED ON. 19/12/2018	

SUB:	COVER MANUAL RELEASE	SCALE	NTS
FOR:	Cover Combination Assy	QPC	
OF:	40mm MGL	1	
DES.REF.NO.:	30P 1501	Weight(g)	19.92
DRG. No.:	30P 1501	SHEETS:	1
	ORDNANCE FACTORY TIRUCHIRAPPALI-16.	SHEET No.:	1



DRG NO. 30P 1502

DIMENSIONS ARE IN mm.

UNTOLERATED DIMNS. AS PER IS : 2102 (MED)

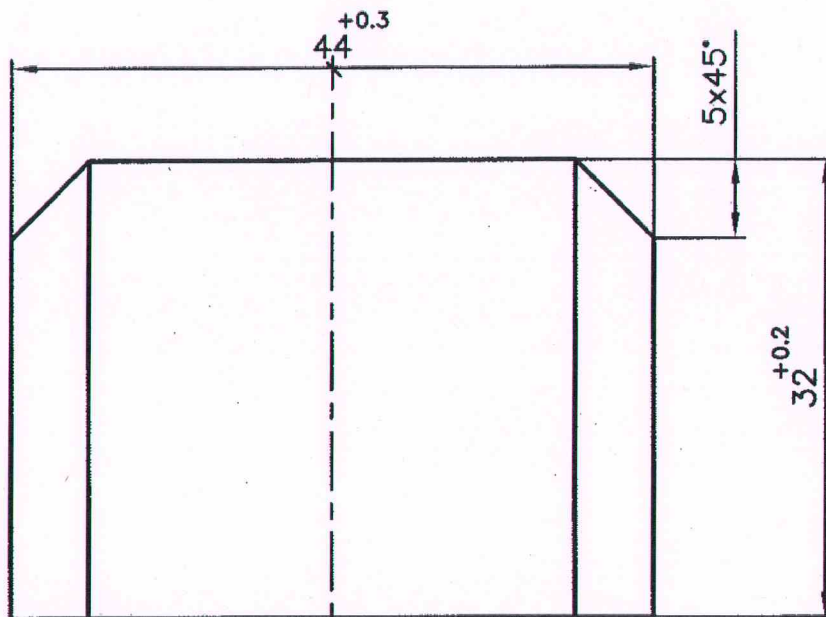

UN CONTROLLED COPY
 CERTIFIED CORRECT COPY OF APPROVED
 DRAWINGS AT THIS DATE: 18/3/22
 DESIGN & DRAWING OFFICE,
 ORDNANCE FACTORY, TIRUCHIRAPPALI - 620 016.

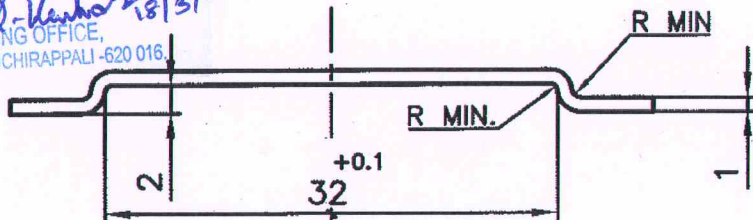

MATERIAL: IS: 2507 - 1975, GRADE -1, DESIGNATION - 45C8.

(OR) BS: 1449, PART-1, 1983, GRADE-CS 40 (OR) CS 50

HARDNESS: 320 - 360 HV

PROTECTIVE FINISH:- AT THE TIME ASSEMBLY

PART NO.	DESCRIPTIONS	NO OFF	MATERIAL	TREATMENT	REMARKS
①	SIGNATURE & DATE.				SCALE 2:1
TRACED					STORE DRG.NO.
DRAWN	<i>S. Venkatesh</i>				OPERATION NO.
CHECKED					SHEETS: 1
HOS/D&DO	<i>[Signature]</i>				SHEET No.: 1
NODAL OFFICER/ FOR MGL	<i>[Signature]</i>				
OFFICER/ D&DO					
AMENDMENTS	SIG. & DATE				
	APPROVED ON: 25/02/2015				

SUB: COVER ACCESS FRONT

FOR: COVER COMBINATION ASSY.

OF: 40mm MGL

DES. REF. NO.

DRG. No.: 30P 1502



ORDNANCE FACTORY
 TIRUCHIRAPPALLI-16.

DRG. NO. 30P 1503

DIMENSIONS ARE IN mm.
 UNTOLERATED DIMNS. AS PER IS : 2102 (MED)

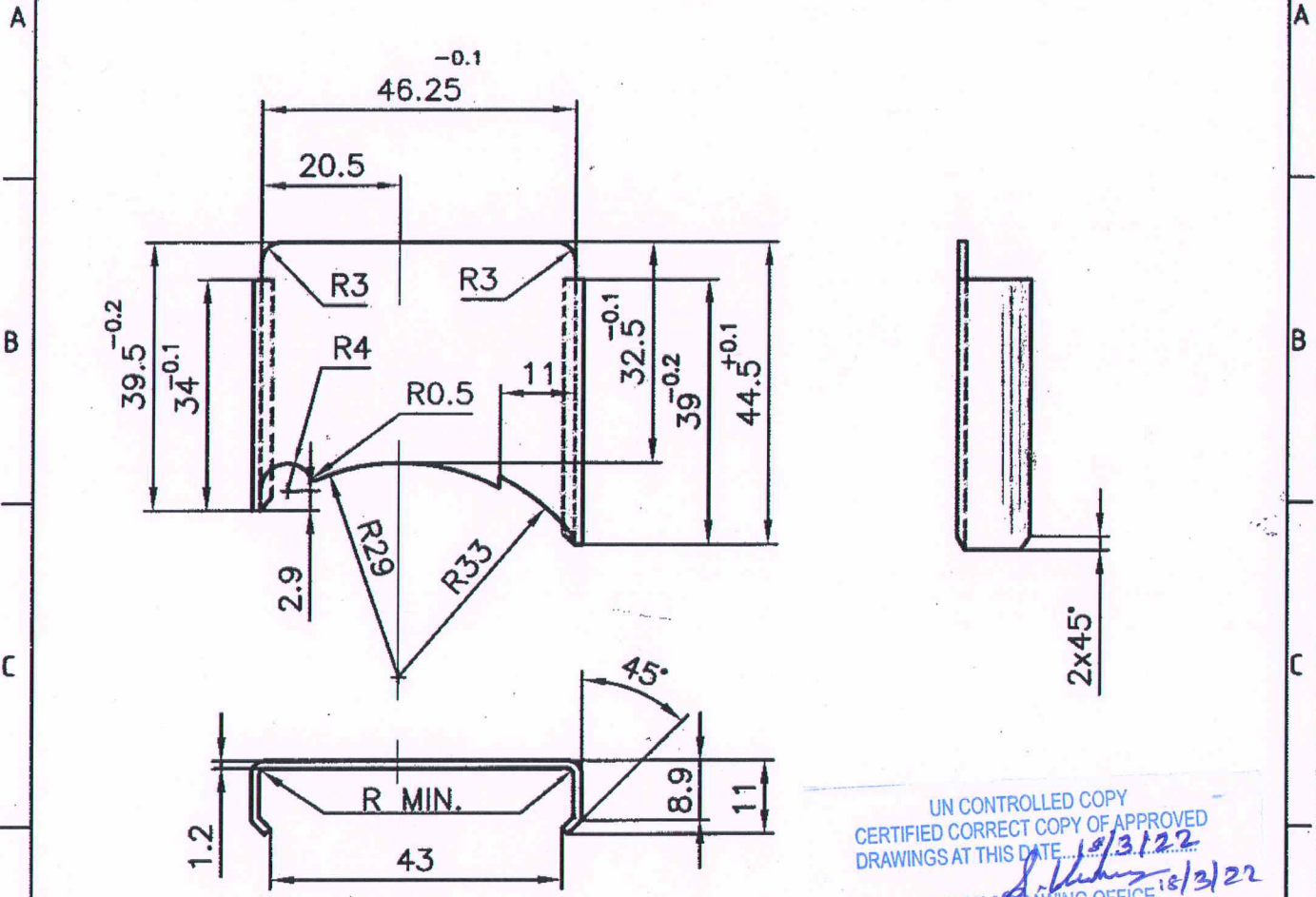

UN CONTROLLED COPY
 CERTIFIED CORRECT COPY OF APPROVED
 DRAWINGS AT THIS DATE... 15/3/22
 DESIGN & DRAWING OFFICE,
 ORDNANCE FACTORY, TIRUCHIRAPPALI -620 016.

MATERIAL: IS: 2507 - 1975, GRADE -1, DESIGNATION - 45C8.
(OR) BS: 1449, PART-1, 1983, GRADE-CS 40 (OR) CS 50

HARDNESS: 320 - 360 HV

PROTECTIVE FINISH:- AT THE TIME OF ASSEMBLY

PART NO.	DESCRIPTIONS	NO OFF	MATERIAL	TREATMENT	REMARKS
	SIGNATURE & DATE.	SUB: <u>COVER ACCESS REAR</u>			SCALE NTS
	TRACED	FOR: <u>COVER COMBINATION ASSY</u>			STORE DRG.NO.
	DRAWN <i>S. Venkatar</i>	OF: <u>40mm MGL</u>			OPERATION NO.
	CHECKED	DES. REF. NO.			SHEETS: 1
	HOS/D&DO <i>[Signature]</i>	DRG. No.: <u>30P 1503</u>			SHEET No.: 1
	NODAL OFFICER/ FOR MGL. <i>[Signature]</i>	 ORDNANCE FACTORY TIRUCHIRAPPALI-16.			
	OFFICER/ D&DO <i>[Signature]</i>				
AMENDMENTS	SIG. & DATE	APPROVED ON: 25/02/2015			

DRG. NO. 30P 1504

DIMENSIONS ARE IN mm.
 UNTOLERATED DIMNS. AS PER IS : 2102 (MED)

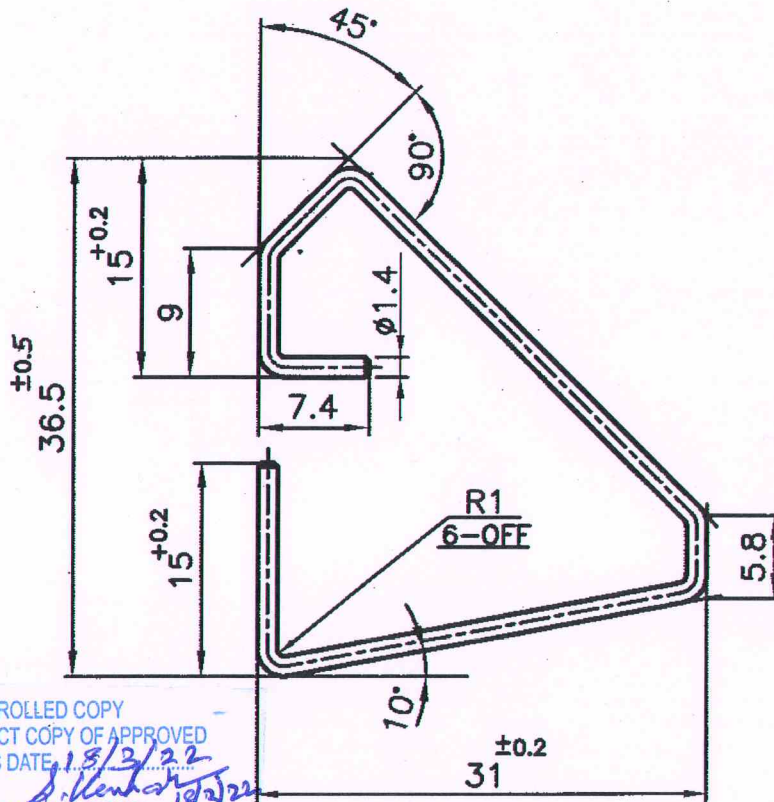

UN CONTROLLED COPY
 CERTIFIED CORRECT COPY OF APPROVED
 DRAWINGS AT THIS DATE: 18/3/22

DESIGN & DRAWING OFFICE,
 ORDNANCE FACTORY, TIRUCHIRAPPALI -620 016.

MATERIAL:- STEEL IS:4454,PART-1, 2001, GRADE-SH.

PROTECTIVE FINISH: PHOSPHATED TO SPECN: JSS: 0465-01-1988 CLASS - 1
 OIL FINISH.

PART NO.	DESCRIPTIONS	NO OFF	MATERIAL	TREATMENT	REMARKS
	SIGNATURE & DATE.	SUB: SPRING COVER ACCESS			SCALE 2:1
TRACED		FOR: COVER COMBINATION ASSY			STORE DRG.NO.
DRAWN	<i>S. Venkatesh</i>	OF: 40mm MGL			OPERATION NO.
CHECKED		DES. REF. NO.			
HOS/D&DO	<i>[Signature]</i>	DRG. No.: 30P 1504			
NODAL OFFICER/ FOR MGL.		 ORDNANCE FACTORY TIRUCHIRAPPALI-16.			SHEETS: 1
OFFICER/ D&DO					SHEET No.: 1
AMENDMENTS	SIG. & DATE	APPROVED ON: 25/02/2015			